

**Agilent 4294A Precision Impedance Analyzer**

# **Programming Manual**

**Sixth Edition**

## **FIRMWARE REVISIONS**

This manual applies directly to instruments that have the firmware revision 1.1x.

For additional information about firmware revisions, see Appendix A.

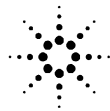

**Agilent Technologies**

Part No. 04294-90051

**November 2002**

Printed in Japan

---

## Notices

The information contained in this document is subject to change without notice.

This document contains proprietary information that is protected by copyright. All rights are reserved. No part of this document may be photocopied, reproduced, or translated to another language without the prior written consent of Agilent Technologies.

Agilent Technologies Japan, Ltd.

Kobe Instrument Division

1-3-2, Murotani, Nishi-Ku, Kobe-shi, Hyogo, 651-2241 Japan

MS-DOS, Windows, Windows 95, Windows NT, Visual C++, Visual Basic and Excel are U.S. registered trademarks of Microsoft Corporation.

UNIX is a registered trademark in the United States and other countries, licensed exclusively through X/Open Company Limited.

Copyright © 1999, 2000, 2002 Agilent Technologies Japan, Ltd.

---

## Manual Printing History

The manual's printing date and part number indicate its current edition. The printing date changes when a new edition is printed. (Minor corrections and updates incorporated in reprints do not necessitate a new printing date.) The manual part number changes when extensive technical changes are incorporated.

April 1999	First Edition (Agilent P/N: 04294-90001)
June 1999	Second Edition (Agilent P/N: 04294-90011)
December 1999	Third Edition (Agilent P/N: 04294-90021)
May 2000	Fourth Edition (Agilent P/N: 04294-90031)
May 2002	Fifth Edition (Agilent P/N: 04294-90041)
November 2002	Sixth Edition (Agilent P/N: 04294-90051)

---

## Sample Program Disk

A sample program disk (Agilent Part Number 04294-18020) is supplied with this manual. The disk contains the sample programs listed in this manual.

The customer shall have the personal, nontransferable rights to use, copy, or modify SAMPLE PROGRAMS in this manual for the Customer's internal operations. The customer shall use the SAMPLE PROGRAMS solely and exclusively for their own purpose and shall not license, lease, market, or distribute the SAMPLE PROGRAMS or modifications of any part thereof.

Agilent Technologies shall not be liable for the quality, performance, or behavior of the SAMPLE PROGRAMS. Agilent Technologies especially disclaims that the operation of the SAMPLE PROGRAMS shall be uninterrupted or error free. The SAMPLE PROGRAMS are provided AS IS.

**AGILENT TECHNOLOGIES DISCLAIMS IMPLIED WARRANTIES OF MERCHANTABILITY AND FITNESS FOR A PARTICULAR PURPOSE.**

Agilent Technologies shall not be liable for any infringement of any patent, trademark, copyright, or other proprietary rights by the SAMPLE PROGRAMS or their use. Agilent Technologies does not warrant that the SAMPLE PROGRAMS are free from infringements of such rights of third parties. However, Agilent Technologies will not knowingly infringe or deliver software that infringes the patent, trademark, copyright, or other proprietary right of a third party.





<b>1. To make effective use of this manual</b>	
Contents of this manual	20
How To Use This Manual	22
Sample programs	22
Other manuals attached to this unit	23
Operation Manual (part number: 04294-900x0)	23
HP Instrument BASIC User's Handbook (part number: E2083-90005)	23
Service Manual (option 0BW only) (part number: 04294-901x0)	23
<b>2. Remote Control, Overview</b>	
GPIB Remote Control System, Overview	26
System configuration	26
Controller	28
Device selector	28
Sending GPIB Command Messages	29
GPIB commands	29
Message syntax	29
The Basics of Writing/Running Programs	30
An easy way to write a program	30
Running the program	32
Saving and Reading the Program	33
Saving the program generated	33
Reading the saved file	33
Remote Control using a LAN	34
<b>3. Setting Measurement Conditions</b>	
Setting Measurement Parameters	36
Setting Measurement Signals	38
Setting the oscillator	38
Setting a dc bias	38
Setting a Sweep Condition	39
Setting a sweep parameter	39
Setting a sweep range	39
Setting sweep time	39
Setting a sweep direction	39
Setting a sweep type	39
Setting the On-screen Arrangement	40
Setting how the way traces are displayed	40
Setting a display scale	41
Setting Averaging	43
Setting a measurement bandwidth	43
Setting averaging	43
Combining Two or More Sweep Conditions (List Sweep)	44
Making/editing a segment	44
Deleting a segment	45
Setting the trace color of each segment	45
Setting the Limit Test Functions	46
Making/editing a segment	46

---

# Contents

Deleting a segment . . . . .	47
Moving offset ranges . . . . .	47
Saving/Recalling Measurement Conditions . . . . .	48
A Sample Program for Setting Measurement Conditions . . . . .	49
<b>4. Preparing For Accurate Measurement</b>	
Adapter Setting . . . . .	54
User Calibration . . . . .	58
Fixture Compensation . . . . .	63
Port Extension Compensation . . . . .	70
<b>5. Starting a Measurement (Trigger) and Detecting the Completion of a Measurement (End of Sweeps)</b>	
Triggering a Measurement (Starting a Measurement) . . . . .	72
Trigger system. . . . .	72
Triggering a measurement . . . . .	73
Waiting for the Completion of One or More Sweeps (Detecting the Completion of a Measurement) . . . . .	74
Using the status register . . . . .	74
Using the *OPC? command . . . . .	76
Inserting a wait . . . . .	76
<b>6. Reading/Writing Measurement Data</b>	
Data Transfer Format . . . . .	78
ASCII format (Form 4). . . . .	78
IEEE 32-bit floating point format (Form 2) . . . . .	79
IEEE 64-bit floating point format (Form 3) . . . . .	80
MS-DOS personal computer format (Form 5) . . . . .	80
Internal Data Processing. . . . .	81
Data processing sequence . . . . .	81
Internal data arrays . . . . .	81
Reading/Writing Data. . . . .	84
Reading/writing measurement data . . . . .	84
Reading level monitoring results . . . . .	87
Reading limit test results. . . . .	89
When to read/write data . . . . .	93
<b>7. Processing Measurement Results</b>	
Reading Measurement Data at Specific Measurement Points (Using the Marker Function). . . . .	96
Moving the marker . . . . .	96
Reading the marker-specified value . . . . .	98
Sample program for using the marker function . . . . .	98
Analyzing Measurement Results . . . . .	100
Equivalent circuit analysis . . . . .	100
Statistics analysis . . . . .	102
Bandwidth analysis. . . . .	103
Various analysis methods available with waveform analysis commands. . . . .	106
<b>8. Saving/Recalling a Measurement Result/Measurement Setup</b>	
Save/Recall of a File. . . . .	112

Specifying a location for save/recall . . . . .	112
Saving data into a file . . . . .	112
Recalling a file . . . . .	113
Copying/deleting a file . . . . .	114
Creating a directory . . . . .	114
Sample Program for Save/Recall . . . . .	115
<b>9. Communication with External Equipment (Using the I/O Ports)</b>	
Using the I/O Ports . . . . .	120
8-bit I/O port . . . . .	120
24-bit I/O port . . . . .	122
Sample Program to Use the I/O Port . . . . .	129
<b>10. Handling Errors</b>	
Using the Status Register . . . . .	132
Using the Error Queue . . . . .	133
Sample program for error handling . . . . .	134
<b>11. Using HP Instrument BASIC</b>	
HP Instrument BASIC, Overview . . . . .	138
Controlling the Agilent 4294A . . . . .	138
Reserving an Area for BASIC on the Screen . . . . .	139
Entering BASIC Commands Using the Keys Located on the Front Panel . . . . .	139
Editing a Program . . . . .	140
Starting up and exiting edit mode . . . . .	140
Editing a program . . . . .	140
Re-numbering a line number . . . . .	142
Running a Program . . . . .	143
Running a program through the softkey interface . . . . .	143
Automatically starting a program at power-on . . . . .	143
Listing a Program (LIST) . . . . .	144
Displaying a program listing on the screen . . . . .	144
Outputting a program listing to the printer . . . . .	144
Saving a Program (SAVE) . . . . .	145
Listing File Names (CAT) . . . . .	146
Displaying a list of file names on the screen . . . . .	146
Outputting a list of file names to the printer . . . . .	146
Reading a Program (GET) . . . . .	147
ON KEY LABEL Functions . . . . .	148
Pass Control Involved with an External Controller . . . . .	149
Pass control . . . . .	149
Communicating with an external controller . . . . .	150
Usable I/O Interfaces and Select Code . . . . .	151
External RUN/CONTInue Connector . . . . .	151
Displaying Graphics . . . . .	152
Graphics commands of Instrument BASIC . . . . .	152
Hard copy . . . . .	153
Default setting . . . . .	153

---

# Contents

A sample graphics program .....	153
Keyboard .....	154
Character entry keys .....	154
Cursor control and display control .....	154
Numeric keys .....	155
Edit keys .....	155
Program control keys .....	155
System control keys .....	156
Softkeys .....	156
Soft control keys .....	156
Softkeys accessed from [Shift]+[F9] key.. .....	157
The [Ctrl] in edit mode .....	158
Displaying program execution status .....	158
Instrument BASIC Commands Specific to the Agilent 4294A .....	159
DATE .....	159
DATES .....	159
READIO .....	160
SET TIME .....	160
SET TIMEDATE .....	160
TIME .....	161
TIMES .....	161
WRITEIO .....	161
Instrument BASIC Commands that Cannot be Run on the Agilent 4294A .....	162
<b>12. Using LAN</b>	
Advantages of LAN Connection .....	164
Getting Ready for Using LAN .....	165
Getting ready for LAN connection .....	165
Connecting with LAN .....	166
Transferring Files .....	167
File transfer procedure using ftp .....	167
File transfer procedure using a file transfer application .....	169
Saving/Recalling a File in/from an External Computer .....	171
Controlling the Agilent 4294A .....	174
Control by use of sockets .....	174
Control by making use of the dynamic data disk .....	184
<b>13. Application Sample Programs</b>	
Basic Measurement .....	186
Measuring Dielectric Material .....	190
Measurement Procedure .....	190
Sample Program for Contacting Electrode Method .....	193
Sample Program for Non-Contacting Electrode Method .....	205
Measuring Magnetic Materials .....	213
Measurement Procedure .....	213
Sample Program .....	215
Measurement controlling oscillator level .....	224
Measurement using scanner .....	229

Measurement procedure .....	229
Sample program .....	231
<b>14. Using Printer</b>	
Printing onto a Printer Directly Connected to Agilent 4294A .....	240
Setting images to be printed .....	240
How to print screen .....	241
Printing onto a Printer Available on an External Computer .....	242
<b>15. Setting the Display (LCD)</b>	
Setting the LCD Screen .....	244
Setting colors for images on the LCD screen .....	244
Setting overall condition for the LCD screen .....	244
Restoring factory setting .....	244
Sample program for setting the LCD screen .....	245
<b>16. GPIB Command Reference</b>	
Notational conventions in this command reference .....	248
Syntax .....	248
Description .....	248
Parameters .....	248
Query response .....	248
Corresponding key .....	249
IEEE common command .....	250
*CLS .....	250
*ESE .....	250
*ESR? .....	251
*IDN? .....	251
*OPC .....	251
*OPC? .....	251
*OPT? .....	252
*RST .....	252
*SRE .....	252
*STB? .....	253
*TRG .....	253
*TST? .....	253
*WAI .....	254
The Agilent 4294A commands .....	255
ACCUD .....	255
ADDRCONT .....	255
ADDRGW .....	256
ADDRIP .....	257
ANAODATA .....	258
ANAOMEMO .....	258
ANARANG .....	259
ANARFULL .....	260
ANASEGM .....	260
AUTO .....	260

---

## Contents

AVER	261
AVERFACT	261
AVERREST	261
BACI	262
BEEPDONE	262
BEEPFAIL	263
BEEPWARN	263
BLIGHT	264
BMON	264
BOTV	265
BWFACT	266
CAL{A B C}	266
CALDON	266
CALECPARA	267
CALP	267
CALQUI	267
CALS	267
CALST	268
CBRI	268
CENT	269
CHAD	270
CIN	270
CLEL	271
CLES	271
COLO	272
COLOR	273
COM{A B C}	273
COMS	273
COMST{A B C}	274
CONT	274
COPA	274
COPT	275
COUT	275
CRED	276
CWFREQ	276
DATMEM	277
DATOVAL	277
DCALLOAD{R L}	278
DCALOPEN{G C}	279
DCALSHOR{R L}	280
DCI	281
DCMOD	281
DCO	282
DCOMLOAD{R L}	282
DCOMOPEN{G C}	283
DCOMSHOR{R L}	284
DCRNG	284
DCV	285
DEFC	285

DEFEC{R1 C1 L1 C0}	286
DFLT	287
DIN	287
DISA	288
DISECIRC	288
DISECPARA	289
DISL	289
DISLLIST	289
DISMAMP	290
DISMPRM	290
DISP	291
DMKR	292
DMKRAUV	293
DMKRP	294
DMKRPRM	295
DMKRVAL	296
DMODE	297
DOUT	297
DPI	298
DSKEY	298
E4TP	299
ECAL{P A B C}	299
ECALDON	299
ECALQUI	300
EDITDONE	300
EDITLIML	300
EDITLIST	300
ENKEY	300
EQUC	301
EQUC0?	301
EQUCPARS4?	302
ESB?	303
ESNB	304
EXPP	304
FILC	305
FMT	305
FORM2	306
FORM3	306
FORM4	306
FORM5	306
FORMFEED	307
HIDI	307
HOLD	307
INID	308
INP8IO?	308
INPT?	308
INPUCALC{1-3}	309
INPUCOMC{1-3}	310
INPUDATA	310

---

## Contents

INPUOTRC	311
INTE	311
KEY	312
LANDSCAPE	313
LIMCLEL	313
LIMDSTAR	314
LIMDSTOP	315
LIMEDONE	315
LIMIAMPO	316
LIMIPRMO	316
LIMITEST	317
LIMLSTAR	317
LIMLSTOP	318
LIMSADD	319
LIMSDEL	320
LIMSDON	320
LIMSEDI	321
LIMSEGM	322
LIMSQUI	322
LIMSTAR	323
LIMSTEST	324
LIMSTOP	325
LIMUSTAR	326
LIMUSTOP	327
LIMVSTAR	328
LIMVSTOP	329
LISPAN	330
LISV	330
LMARG	331
LMAXS?	332
LMINS?	333
MANP	334
MANR	335
MANS	336
MAXDCV	336
MEAS	337
MEASTAT	338
MINDCV	339
MKR	339
MKRAMPO	340
MKRAUV?	340
MKRCENT	340
MKRCOUP	341
MKRDSPAN	341
MKRL	341
MKRLIMSTAR	342
MKRLIMSTOP	342
MKRLIMVSTAR	343
MKRLIMVSTOP	343



MKRMANP	343
MKRMON	344
MKRMOV	344
MKRO	345
MKROFS	345
MKRP	346
MKRPKD	346
MKRPRM	347
MKRREF	347
MKRSTAR	348
MKRSTOP	348
MKRTR	348
MKRTRMAX	348
MKRTRMIN	349
MKRVAL?	349
MKRXUNIT	350
MKRZM	350
NEGL	351
NEXNPK?	351
NEXP	352
NEXPK?	352
NPEAK?	353
NUMG	353
OMON	354
OPEP	354
OSE	354
OSER?	355
OSNT	355
OSPT	356
OSR?	356
OUT1 {H L}	356
OUT1ENV {H L}	356
OUT2 {H L}	357
OUT2ENV {H L}	357
OUT8IO	357
OUTAIO	358
OUTBIO	358
OUTCIO	359
OUTDIO	359
OUTEIO	360
OUTFIO	360
OUTGIO	361
OUTHIO	361
OUTPCALC{1-3}?	362
OUTPCERR?	362
OUTPCOMC{1-3}?	363
OUTPDATA?	364
OUTPDATAP?	364
OUTPDC?	365

---

## Contents

OUTPDCP?	365
OUTPDMKR?	366
OUTPDTRC?	367
OUTPDTRCP?	368
OUTPERRO?	369
OUTPFAIP?	369
OUTPIAC?	369
OUTPIACP?	370
OUTPINPCIO?	370
OUTPINPDIO?	371
OUTPINPEIO?	371
OUTPLIMF?	372
OUTPLIML?	372
OUTPLIMM?	373
OUTPMAX?	373
OUTPMEMO?	374
OUTPMEMOP?	374
OUTPMIN?	375
OUTPMINMAX?	375
OUTPMKR?	376
OUTPMSTA?	377
OUTPMTRC?	377
OUTPMTRCP?	378
OUTPMWID?	379
OUTPRESO?	380
OUTPRESR?	381
OUTPSMKR{1-7}?	382
OUTPSWPRM?	383
OUTPSWPRMP?	383
OUTPVAC?	383
OUTPVACP?	384
PARS	384
PAVER	385
PAVERFACT	385
PDELT	386
PEAK?	386
PEAKCENT	387
PHAU	387
PKDLTX	388
PKDLTY	389
PKPOL	389
POIN	390
PORE	390
PORTL	391
PORTZ	391
POSL	392
POWE	392
POWMOD	393
PREP	393

PRES	393
PRIC	394
PRINALL	394
PRSOFT	394
PURG	395
RECD	395
REFP	396
REFV	397
REFX	398
REFY	398
RESAVD	399
RESD	399
RPLHEI?	400
RPLLHEI?	400
RPLPP?	400
RPLPPS?	401
RPLRHEI?	401
RSCO	401
SADD	402
SAVCAL	403
SAVDASC	403
SAVDAT	404
SAVDDAT	404
SAVDS1P	405
SAVDSTA	406
SAVDTIF	406
SAVDTRC	407
SAVMEM	407
SAVMTRC	408
SAVPSTA	408
SCAC	409
SCAF	409
SCAL	410
SCOL	411
SCRN	411
SDEL	412
SDELT	413
SDON	413
SEAL	413
SEAM	414
SEANPK	414
SEANPKL	414
SEANPKR	415
SEAR	415
SEARLINE	415
SEARMAX	416
SEARMAXP	417
SEARMIN	418
SEARMINP	419

---

## Contents

SEARNG	419
SEATARG	420
SEATARGL	420
SEDI	421
SEGM	422
SEGMNUM	423
SETCDATE	423
SETCTIME	424
SIMFCHAR	424
SING	424
SMKR{1-7}	425
SMKRAUV{1-7}?	425
SMKRP{1-7}	426
SMKRPRM{1-7}	427
SMKRVAL{1-7}?	428
SPAN	429
SPLD	430
STAR	431
STOD	432
STOP	433
SUBNET	434
SWED	435
SWET	435
SWPP	436
SWPT	436
TARL?	437
TARR?	438
THRR	439
TINT	441
TITL	441
TMARG	442
TOPV	443
TRAC	444
TRACK	444
TRGEVE	445
TRGP	445
TRGS	446
USKEY	446
WIDFVAL	447
WIDSIN	447
WIDSOUT	448
WIDT	448
WIDVTYPE	449
ZMAPER	450
Instrument BASIC control commands	451
:PROGram:CATalog?	451
:PROGram[:SELected]:DEFine	451
:PROGram[:SELected]:DELete:ALL	452
:PROGram[:SELected]:DELete:[SELected]	452

:PROGram[:SElected]:EXECute . . . . .	452
:PROGram[:SElected]:MALLocate . . . . .	452
:PROGram[:SElected]:NAME . . . . .	453
:PROGram[:SElected]:NUMBer . . . . .	453
:PROGram[:SElected]:STATe . . . . .	454
:PROGram[:SElected]:STRing . . . . .	454
:PROGram[:SElected]:WAIT . . . . .	455
Commands starting with :PROGram:EXPLicit . . . . .	455
<b>A. Manual Changes</b>	
Manual Changes . . . . .	458
Change 1 . . . . .	459
Change to the revision 1.0x . . . . .	459
<b>B. Status Reporting System</b>	
General Status Register Model . . . . .	462
Event register . . . . .	463
Enable register . . . . .	463
Status byte register . . . . .	463
Transition filter and condition register . . . . .	464
Status Register Structure . . . . .	465
<b>C. GPIB command table</b>	
GPIB command list sorted according to function . . . . .	470
<b>D. Error messages</b>	
Order of error number . . . . .	480



---

# 1 To make effective use of this manual

This chapter describes the contents and the use of this manual and makes references to various other manuals.

## **Contents of this manual**

This manual is a guide to writing BASIC programs for the Agilent 4294A precision impedance analyzer.

Chapter 1 , “To make effective use of this manual.”

This chapter describes the contents and the use of this manual and makes references to various other manuals.

Chapter 2 , “Remote Control, Overview.”

This chapter describes how to set up a GPIB remote control system and the basic use of GPIB commands.

Chapter 3 , “Setting Measurement Conditions.”

This chapter describes how to set measurement conditions.

Chapter 4 , “Preparing For Accurate Measurement.”

This chapter describes how to apply adapter setting, user calibration, fixture compensation, and port extension compensation.

Chapter 5 , “Starting a Measurement (Trigger) and Detecting the Completion of a Measurement (End of Sweeps).”

This chapter describes how to generate a trigger to start a measurement and how to detect the completion of a measurement.

Chapter 6 , “Reading/Writing Measurement Data.”

This chapter describes how to read and write measurement data and how to obtain level monitoring and limit test results.

Chapter 7 , “Processing Measurement Results.”

This chapter describes how to process measurement results using the marker function, the equivalent circuit analysis function, the trace bandwidth analysis function, and analysis commands.

Chapter 8 , “Saving/Recalling a Measurement Result/Measurement Setup.”

This chapter describes how to save/recall a measurement result, measurement setup, and other data into/from a file.

Chapter 9 , “Communication with External Equipment (Using the I/O Ports).”

This chapter describes how to use the 8-bit I/O port and the 24-bit I/O port of the Agilent 4294A to communicate with external equipment (for example, handlers in production lines).

Chapter 10 , “Handling Errors.”

This chapter describes how to handle errors that may occur in the Agilent 4294A while running a program.



#### Chapter 11 , “Using HP Instrument BASIC.”

This chapter gives an overview of HP Instrument BASIC and explains how to use the keyboard. Read this chapter before using the HP Instrument BASIC program installed in the Agilent 4294A.

#### Chapter 12 , “Using LAN.”

This chapter describes LAN (Local Area Network)-based file transfer and remote control.

#### Chapter 13 , “Application Sample Programs.”

This chapter provides sample measurements (sample programs).

#### Chapter 14 , “Using Printer.”

This chapter describes the procedures for printing out your measurement results with a printer.

#### Chapter 15 , “Setting the Display (LCD).”

This chapter describes the procedures for setting the displayed colors of traces and characters as well as the brightness of the LCD display.

#### Chapter 16 , “GPIB Command Reference.”

This chapter is the GPIB command reference for the Agilent 4294A. The IEEE common commands, the 4294A commands, and the Instrument BASIC control commands are described in alphabetical order.

#### Appendix A , “Manual Changes.”

This appendix contains the information required to adapt this manual to earlier versions or configurations of the Agilent 4294A than the current printing date of this manual. The information in this manual applies directly to a 4294A model that has a serial number prefix listed on the title page of this manual.

#### Appendix B , “Status Reporting System.”

This appendix describes the status reporting system of the Agilent 4294A.

#### Appendix C , “GPIB command table.”

This appendix provides the Agilent 4294A GPIB command list sorted according to function.

#### Appendix D , “Error messages.”

The Agilent 4294A provides error messages to indicate its operating status. This appendix describes the error messages of the the 4294A.

## **How To Use This Manual**

This manual may be used as follows depending on how familiar you are with writing BASIC programs.

1. If you have experience in writing programs for the GPIB system, pick sample programs suitable for your application out of those given in this manual.
2. If you have no experience in writing programs for GPIB equipment, it is best for you to read this manual thoroughly from the beginning. In particular, Chapter 2 , “Remote Control, Overview,” describes entry-level programming skills.
3. Sample programs can be useful as “programming hints” for some GPIB commands. For descriptions of GPIB commands in detail, see Chapter 16 , “GPIB Command Reference.”
4. You can also use HP Instrument BASIC functions with the Agilent 4294A. Chapter 11 , “Using HP Instrument BASIC,” describes how to use Instrument BASIC. Read this chapter if you are a novice in Instrument BASIC.

### **Sample programs**

The HP BASIC sample programs given in this manual are stored in text form in the sample program disk (part number 04294-18010) attached to this manual. These sample programs are in DOS format.

#### **How to load a sample program**

To use a sample program, load it into HP BASIC by use of the GET command. The example below shows a command in which the sample program setup.bas is loaded.

```
GET "setup.bas"
```

---

## Other manuals attached to this unit

Read the manuals below when using the Agilent 4294A.

### ***Operation Manual*** (part number: 04294-900x0)

Most basic information necessary for using the Agilent 4294A is described in this manual. It includes installation procedures, explanations of measurement operations, example measurements, performances (specifications), and information on options and accessories. For GPIB programming, see this manual together with “HP Instrument BASIC User's Handbook”.

### ***HP Instrument BASIC User's Handbook*** (part number: E2083-90005)

This manual explains how to use HP Instrument BASIC by giving sample programs and general suggestions, and a description of every HP Instrument BASIC command. This manual has three parts: “HP Instrument BASIC Programming Technique,” “HP Instrument BASIC Interface Technique,” and “HP Instrument BASIC Language Reference.”

### ***Service Manual (option 0BW only)*** (part number: 04294-901x0)

This manual describes how to adjust and repair the Agilent 4294A and how to carry out performance tests. This manual will be attached if you choose option 0BW.

To make effective use of this manual  
**Other manuals attached to this unit**

---

## 2

# Remote Control, Overview

This chapter describes how to set up a GPIB remote control system and the basic use of GPIB commands.

## GPIB Remote Control System, Overview

This section describes the configuration of the GPIB remote control system.

### System configuration

Connect the Agilent 4294A and an external controller (computer) with a GPIB cable. Figure 2-1 shows an overview of the configuration of an GPIB remote control system.

Figure 2-1

### Configuration of GPIB remote control system

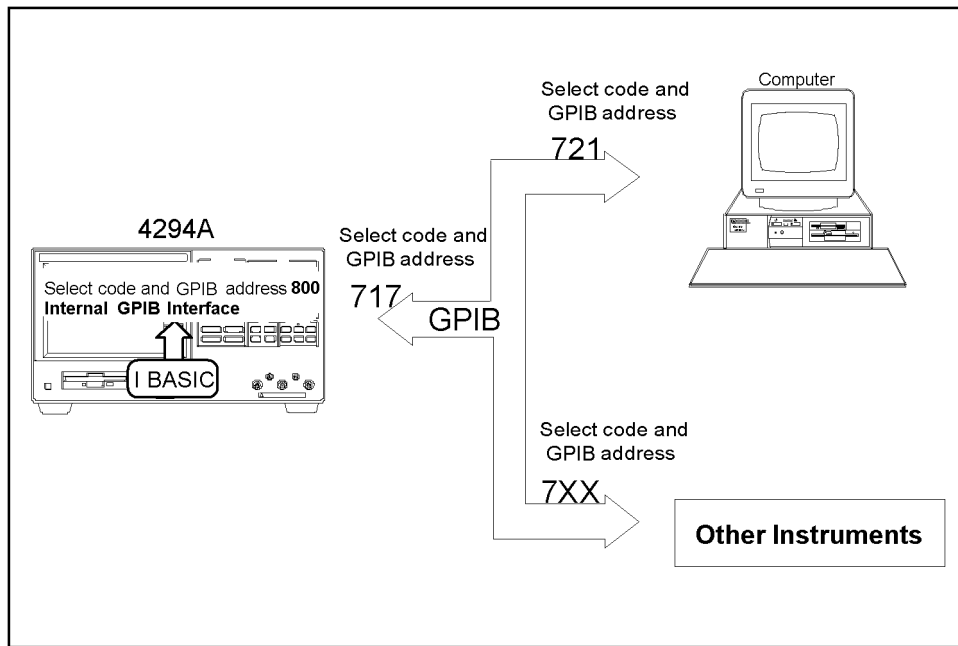

4294ape013

### What is GPIB?

GPIB (General Purpose Interface Bus) is one of the interface standards for connecting a computer and peripheral devices and complies with IEEE 488.1, IEC-625, IEEE 488.2 and JIS-C1901, which are worldwide standards. Using the GPIB interface allows you to control the Agilent 4294A from an external computer. The computer sends commands and instructions through the GPIB to the 4294A and receives data sent from the 4294A.

## Necessary equipment

1. The Agilent 4294A precision impedance analyzer and accessories necessary for measuring test samples
2. GPIB system controller

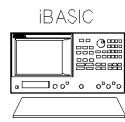

You can use the Agilent 4294A as a system controller. To use HP Instrument BASIC without an external computer, set the 4294A to system controller mode. For details, see Chapter 11 , “Using HP Instrument BASIC.”

or



You can use an external computer as a system controller. This requires an HP Vectra PC (or an IBM PC compatible) mounted with a GPIB interface such as HP 82341D or the HP 9000 series 700 mounted with a GPIB interface such as HP E2071D. In either case, software such as HP BASIC for Windows or the like is required for controlling this unit through the GPIB. The HP 9000 series 300 may also be used, but if this computer is used several peripheral devices are also required.

To use an external computer as a system controller:

- a. set the 4294A in addressable-only mode.

Press **[Local] - ADDRESSABLE ONLY**.

- b. Set the GPIB's address to 17.

Press **[Local] - ADDRESS HPIB: - [1] - [7] - [x1]**.

3. Peripheral devices compliant with the intended use and various additional devices
4. GPIB cables (10833A/B/C/D) used for connecting the computer, the Agilent 4294A, and peripheral devices

### The system size you can set up

- You can connect up to 15 devices with a single GPIB system.
- The length of a cable that connects one device with another must not be more than 4 meters. The total length of connection cables used in a single GPIB system should not be more than 2 meters times the number of devices (counting the controller as one device). You cannot set up a system makeup in which the total cable length exceeds 20 meters.
- Limit the number of connectors attached to a single device to four. Attaching five or more connectors exerts excessive force on them and may cause failure.
- Star, linear, and combinational cable configurations are allowed. You must not use a loop configuration.

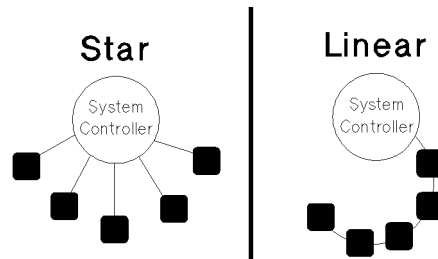

### Controller

A device that can permit talking (outputting data) and listening (receiving data) is called a controller, as opposed to a GPIB device.

The active controller, if connected to two or more controllers, can control other devices on the bus. Only one controller among multiple controllers can be active at a given time. The active controller can pass control to another controller by use of the PASS CONTROL command.

When the power of the system controller is turned on, it becomes the active controller. When another controller is active, the system controller can execute the “ABORT <select code>” command at any time so that it becomes the active controller.

### Device selector

GPIB device control is carried out by receiving commands from the active controller. The active controller can operate the device selector to select a target device.

HP Instrument BASIC is connected to the Agilent 4294A by its interface installed in the 4294A. The interface select code of the built-in interface is set to 8 so as to distinguish it from the external select code 7.

Since this unit alone is connected to the built-in interface, any address from “00” through “30” may be used to specify the analyzer used with the internal connection from Instrument BASIC. In this unit, address “00” is used so that the device selector turns to “800”.



---

## Sending GPIB Command Messages

### GPIB commands

GPIB commands can be grouped into two classes:

#### IEEE common commands

Commands defined by IEEE488.2

#### Agilent 4294A commands

Commands specific to the Agilent 4294A. These include all of the measurement functions and some of the general-purpose functions.

### Message syntax

Descriptions of the syntax used in sending program messages from the GPIB are given below. A program message is sent from an external controller to a measuring instrument. The content of a program message is composed of a series of commands that are properly set off and terminated by delimiters and a message terminator.

#### Uppercase letters and lowercase letters

The difference between uppercase and lowercase letters is disregarded.

#### Program message terminator

A program message must terminate with one of three program message terminators: <new line>, <^END>, or <new line><^END>. <^END> means that EOI turns to the active level on the GPIB interface as soon as the immediately preceding data byte is sent out. For example, the OUTPUT statement of HP BASIC automatically sends a message terminator along with the last data byte.

#### Parameters

A space (ASCII code 32) must be put between the last command mnemonic and the first parameter.

To send two or more parameters by a single command, each parameter must be delimited by a comma (,).

#### A message including two or more commands

To send two or more commands within a single message, each command must be delimited by a semicolon (;). An example is given below in which the "PRES" command and the "\*CLS" command are sent within a single message.

```
OUTPUT 717;"PRES;*CLS"
```

---

## The Basics of Writing/Running Programs

### An easy way to write a program

The following describes a procedure for writing an Instrument BASIC program as an example of simple programming. For more on how to use Instrument BASIC, see Chapter 11, "Using HP Instrument BASIC."

This example sets the Agilent 4294A as shown below.

ACTIVE TRACE block	Trace A (default setting)
MEASUREMENT block	Cs-Rs Linear Y-axis format (default setting) Display scale: automatic
SWEEP block	Center frequency: 70 MHz Span frequency: 100 kHz

In this example, the program can be input by only using the keys located on the front panel without having to touch the keyboard. You can also enter the program with the keyboard.

- Step 1.** Turn on the Agilent 4294A.
- Step 2.** Press the following key and soft keys.

**[System] - IBASIC - Edit**

The system goes into system edit mode. The cursor appears on line 10.

```
10 _
```

- Step 3.** Press the following soft keys.

**ASSIGN @Hp4294**

The command automatically appears at the cursor position.

```
10 ASSIGN @Hp4294 TO 800_
```

- Step 4.** Press the entry following key.

**[x1]**

The command is entered into the System, and the cursor moves to the next line.

```
10 ASSIGN @Hp4294 TO 800
```

```
20 _
```

- Step 5.** Press the following soft keys.

**OUTPUT @Hp4294**

Character strings appear as shown below.

```
10 ASSIGN @Hp4294 TO 800
```

```
20 OUTPUT @Hp4294;" "
```

**Step 6.** Press the following instrument state key to enter the preset command.

**[Preset]**

The GPIB command “;PRES” to be used for presetting the equipment automatically appears at the cursor position.

```
10 ASSIGN @Hp4294 TO 800
20 OUTPUT @Hp4294;";PRES"
```

Next, press[×1].

---

**NOTE**

---

To send two or more commands within a single OUTPUT statement, you need to delimit the commands by a semicolon. In entering GPIB commands with the control panel keys, a semicolon is automatically placed before each command.

**Step 7.** Press the following soft keys to set the measurement parameters Cs-Rs.

**OUTPUT @Hp4294 - [Meas] - Cs-Rs**

Program code is generated as shown below.

```
10 ASSIGN @Hp4294 TO 800
20 OUTPUT @Hp4294;";PRES "
30 OUTPUT @Hp4294;";MEAS CSR"
```

Next, press [×1].

**Step 8.** Press the following keys and soft keys to set a center frequency and a span frequency.

**[System] - IBASIC - OUTPUT @Hp4294 - [Cent] - [7] - [0] - [M/μ] - [Span] - [1] - [0] - [0] - [k/m] - [×1]**

```
10 ASSIGN @Hp4294 TO 800
20 OUTPUT @Hp4294;";PRES"
30 OUTPUT @Hp4294;";MEAS CSR"
40 OUTPUT @Hp4294;";CENT 70E6;SPAN 100E3"
50 _
```

**Step 9.** Press the following keys and soft keys to achieve automatic scaling.

**[System] - IBASIC - OUTPUT @Hp4294 - [Scale Ref] - AUTO SCALE - [×1]**

```
10 ASSIGN @Hp4294 TO 800
20 OUTPUT @Hp4294;";PRES"
30 OUTPUT @Hp4294;";MEAS CSR"
40 OUTPUT @Hp4294;";CENT 70E6;SPAN 100E3"
50 OUTPUT @Hp4294;";AUTO"
60 _
```

## Remote Control, Overview

### The Basics of Writing/Running Programs

**Step 10.** Enter the END command to quit the program.

```
[System] - IBASIC - END - [x1]  
10 ASSIGN @Hp4294 TO 800  
20 OUTPUT @Hp4294;" ;PRES"  
30 OUTPUT @Hp4294;" ;MEAS CSR"  
40 OUTPUT @Hp4294;" ;CENT 70E6;SPAN 100E3"  
50 OUTPUT @Hp4294;" ;AUTO"  
60 END  
70 _
```

**Step 11.** Press the following soft key to exit edit mode.

**done**

The measurement screen returns.

---

#### **NOTE**

In certain cases, some operations to handle user calibration or other tasks cannot be properly programmed.

---

### **Running the program**

Press the following key and soft keys to run the program.

**[System] - IBASIC - Run**

The System runs the program. You can also run the program by typing as below.

RUN **[Enter]**

---

## Saving and Reading the Program

### Saving the program generated

A simple saving procedure is given here. For details see “Saving a Program (SAVE)” on page 145.

**Step 1.** First, connect the keyboard.

**Step 2.** Press the key and soft keys as given below to switch the screen.

**[Display] - more 1/2 - ALLOCATION - ALL BASIC**

**Step 3.** Select a storage unit in which to save the program.

**[System] - IBASIC - more 1/3 - MASS STORE[]**

**Step 4.** Pressing [INTERNAL] selects a floppy disk, [MEMORY] selects a volatile memory disk (RAM disk), or [FLASH MEMORY] selects a nonvolatile memory disk (flash memory disk) for the storage unit.

**Step 5.** Press the key and soft keys as given below.

**[System] - IBASIC - more 1/3 - SAVE**

Then, the screen will look like as shown below.

**SAVE ""**

**Step 6.** Enter an optional file name with the keyboard. If a file having the same name is present in the storage unit, the SAVE command cannot save the file. Either give another file name or use the RE-SAVE command to overwrite the existing file.

### Reading the saved file

**Step 1.** Press the key and soft keys as given below to switch the screen.

**[Display] - more 1/2 - ALLOCATION - ALL BASIC**

**Step 2.** Select the storage unit on which a file in view is present.

**[System] - IBASIC - more 1/3 - MASS STORE[]**

**Step 3.** Press the key and soft keys as given below.

**[System] - IBASIC - more 1/3 - GET**

**Step 4.** Enter the name of the file in view with the keyboard.

**Step 5.** If you are not sure of your file name, use the CAT command to list files and then look up the file name.

## **Remote Control using a LAN**

The Agilent 4294A can be connected to a local area network (LAN). Connecting the 4294A to its external controller via a LAN allows you to efficiently send GPIB commands to and read data from the external controller.

For how to connect to a LAN and how to set up remote control, see Chapter 12 , “Using LAN.”

---

## 3 Setting Measurement Conditions

This chapter describes how to set measurement conditions.

## Setting Measurement Parameters

To set measurement parameters, use the command given below. This command sets measurement parameters for both trace A and trace B at the same time.

- “MEAS” on page 337

You can set measurement parameters in the combinations shown in Table 3-1 depending on the parameters used at the time of sending a command.

**Table 3-1**

**Measurement parameters**

Parameters for sending a command	Parameters to be set	
	Trace A	Trace B
IMPH	Z	$\theta$
IRIM	R	X
LSR	Ls	Rs
LSQ	Ls	Q
CSR	Cs	Rs
CSQ	Cs	Q
CSD	Cs	D
AMPH	Y	$\theta$
ARIM	G	B
LPG	Lp	G
LPQ	Lp	Q
CPG	Cp	G
CPQ	Cp	Q
CPD	Cp	D
COMP	Z	Y
IMLS	Z	Ls
IMCS	Z	Cs
IMLP	Z	Lp
IMCP	Z	Cp
IMRS	Z	Rs
IMQ	Z	Q
IMD	Z	D
LPR	Lp	Rp
CPR	Cp	Rp



The following gives brief descriptions of the measurement parameters in Table 3-1:

$ Z $	Impedance amplitude (absolute value)
$ Y $	Admittance amplitude (absolute value)
$\theta$	Impedance phase (for $ Z -\theta$ ), Admittance phase (for $ Y -\theta$ )
$Z$	Impedance (complex number $(R+jX)$ )
$Y$	Admittance (complex number $(G+jB)$ )
$R, R_s$	Equivalent series resistance
$X$	Equivalent series reactance
$L_s$	Equivalent series inductance
$C_s$	Equivalent series capacitance
$R_p$	Equivalent parallel resistance
$G$	Equivalent parallel conductance
$B$	Equivalent parallel susceptance
$L_p$	Equivalent parallel inductance
$C_p$	Equivalent parallel capacitance
$D$	Dissipation factor
$Q$	Quality factor (Inverse of $D$ )

## Setting Measurement Signals

### Setting the oscillator

To set an oscillator level, use the commands given below.

- “POWMOD” on page 393
- “POWE” on page 392

Either a voltage or a current can be used to set the oscillator level. First, specify whether you use voltage or a current with the “POWMOD” command and then set a level with the “POWE” command.

To set the oscillator frequency during oscillator level sweep and dc bias sweep, use the command given below.

- “CWFREQ” on page 276

### Setting a dc bias

To turn on or off the dc bias output or to select an output mode, use the commands given below.

- “DCO” on page 282
- “DCMOD” on page 281

To set a dc bias level, use the commands given below.

- “DCI” on page 281
- “DCV” on page 285

To set a dc bias output range, use the command given below.

- “DCRNG” on page 284

If the dc bias output is either in constant voltage mode or in constant current mode, use the commands given below to set the limit of the current output or the voltage output. In both constant voltage mode and constant current mode, set the limit of output level in terms of voltage.

- “MAXDCV” on page 336
- “MINDCV” on page 339

---

## Setting a Sweep Condition

### Setting a sweep parameter

Choose a sweep parameter from among the oscillator frequency, oscillator level, and dc bias level. To set the parameter, use the command given below.

- “SWPP” on page 436

The following settings for the sweep condition will be stored in memory for each parameter chosen above.

### Setting a sweep range

There are two ways to set the sweep range: by specifying the central value and span of the sweep range or by specifying the start point and endpoint of the sweep range. To specify the central value and the span, use the commands given below.

- “CENT” on page 269
- “SPAN” on page 429

To specify the start point and the endpoint, use the commands given below.

- “STAR” on page 431
- “STOP” on page 433

To set the number of measurement points within the sweep range, use the command given below.

- “POIN” on page 390

### Setting sweep time

To set the sweep time, use the command given below.

- “SWET” on page 435

You can set the point delay time (waiting time for measurement start at each measurement point) and the sweep delay time (waiting time for sweep start at each sweep). To set them, use the commands given below.

- “PDEL” on page 386
- “SDEL” on page 413

### Setting a sweep direction

To set the sweep direction, use the command given below.

- “SWED” on page 435

### Setting a sweep type

To set the sweep type, use the command given below.

- “SWPT” on page 436

## Setting the On-screen Arrangement

You carry out most of the on-screen arrangement settings independently for trace A and trace B. After made, these will take effect on the active trace. Thus you need to use the command given below to properly switch the active trace settings from one trace to the other.

- “TRAC” on page 444

### Setting how the way traces are displayed

You can select one of two ways to display traces A and B: overlapping the traces in the same area or horizontally splitting the screen into two halves to display the traces separately. When the traces are overlapped, you can set an inactive trace so that it disappears. To make these settings, use the commands given below.

- “SPLD” on page 430
- “HIDI” on page 307

If the measurement results are stored in a memory trace (carried out with the “DATMEM” command on page 277), then set the trace to display by using the command given below.

- “DISP” on page 291

To turn on the function that allows you to accumulate a group of overlapping measurement results without updating each trace’s display, use the command given below.

- “ACCUD” on page 255

---

#### NOTE

The parameters set by use of the “SPLD” and “ACCUD” commands are common to traces A and B.

If a phase is used as the measurement parameter, you can select the unit for the phase to display. You can also specify whether or not to display extended phases (repeatedly displaying phases outside the range of  $-180^\circ$  to  $+180^\circ$ ). To make these settings, use the commands given below.

- “PHAU” on page 387
- “EXPP” on page 304

If a scalar value is used as the measurement parameter, you can set an offset for the data to be displayed in a data trace by using the command given below.

- “DATOVAL” on page 277

## Setting a display scale

If both a data trace and a memory trace are concurrently displayed, you can separately set different scales to these traces. Use the commands given below to specify whether to use the same scale for both data and memory traces or to specify which trace to set a scale to when not using the same scale.

- “SCAC” on page 409
- “SCAF” on page 409

---

### NOTE

The commands above are closely related to displaying a trace, that is, there can be instances in which executing these commands for a purpose other than properly setting a display trace causes an error; for example, changing the settings of the trace to display also changes other items in a linked manner. Therefore, you need to carefully plan the sequence of executing commands in writing a program.

Three ways of setting a display scale are available depending on the display format to be set with the command given below. Accordingly, you need to set a display format before setting a display scale.

- “FMT” on page 305

---

### NOTE

The display format you can choose varies depending on the measurement parameters.

---

### NOTE

Settings for the display scale and display format are set for each parameter. That is, the settings are determined by the parameters selected in the active trace at the time the settings are made, and are not the settings for trace A or trace B.

The following sections describe the method used for each type of format.

### Linear/log Y-axis format

Since the display scale of the X-axis depends on the sweep settings, only set the display scale of the Y-axis (the axis showing the measurement parameter). To set the scale, choose the scale parameter by using one of the commands given below.

- “SCAL” on page 410
- “REFP” on page 396
- “REFV” on page 397
- “TOPV” on page 443
- “BOTV” on page 265

In the case of a log Y-axis, however, you can only make the settings with the “TOPV” and “BOTV” commands. The relations between the commands and the scale parameters are shown in Figure 3-1.

Figure 3-1

Commands for setting display scale parameters

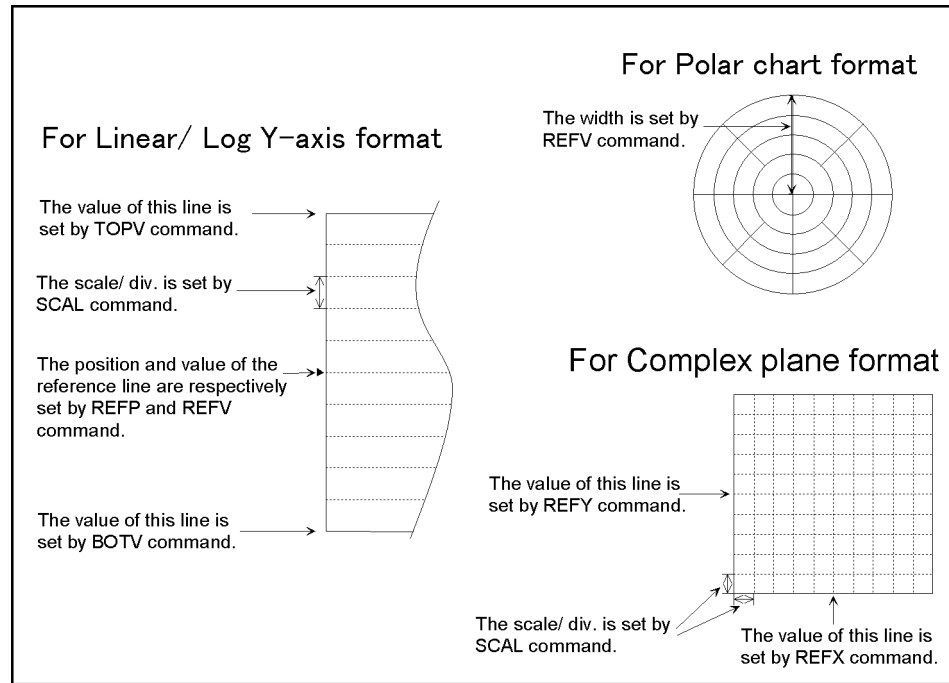

### Polar chart format

Make the settings by using the full-scale value (the value of the outermost circle) only. To make the settings, use the command given below.

- “REFV” on page 397

### Complex plane format

Set the scale parameters by using the commands given below.

- “SCAL” on page 410
- “REFX” on page 398
- “REFY” on page 398

The center line of the grid along the X-axis and that along the Y-axis are always used as the lines for the reference values and cannot be changed. The relations between the commands and the scale parameters are shown in Figure 3-1.

## **Setting Averaging**

### **Setting a measurement bandwidth**

To set a measurement bandwidth, use the command given below.

- “BWFACT” on page 266

### **Setting averaging**

#### **Setting sweep averaging**

To set or control sweep averaging, use the command given below.

- “AVER” on page 261
- “AVERFACT” on page 261
- “AVERREST” on page 261

#### **Setting point averaging**

To set point averaging, use the commands given below.

- “PAVER” on page 385
- “PAVERFACT” on page 385

## Combining Two or More Sweep Conditions (List Sweep)

You can carry out a sweep (list sweep) by combining the segments that set the sweep condition; these segments can provide up to 18 identical sweep parameters. To carry out a list sweep, prepare a table of segments. At the start and the end of the table, send the commands given below.

- “EDITLIST” on page 300
- “EDITDONE” on page 300

---

### NOTE

If the “EDITDONE” command is not executed, the resulting settings from making, editing, and deleting with the commands given below will not take effect. (The table to be used in carrying out a list sweep is left as it was before the execution of the “EDITLIST” command.)

### Making/editing a segment

To make a new segment, use the commands given below. The “SADD” command adds a segment so that you can edit it. To make settings for a segment’s parameters, use the commands for setting identical parameters described in “Setting Measurement Signals” on page 38, “Setting a Sweep Condition” on page 39 and “Setting Averaging” on page 43. After setting the parameters, send the “SDON” command to finish setting the segment.

- “SADD” on page 402
- “SDON” on page 413

Each segment is assigned a segment number (a row number in the table) for specifying the segment to be set, changed or deleted. To specify the number of the segment to be worked on, use the command given below.

- “SEGM” on page 422

Executing the “SADD” command makes an additional insertion under the line of the specified segment (if no segment is specified, then the segment to be worked on at the time of executing the command involved), and the added segment becomes the target of setting. Thus you don’t need to specify segment numbers for the “SADD” command while making a new table by adding segments in the intended sequence. You need to specify a segment number only when adding a new segment at a position between two existing segments.

To change the parameter settings of existing segments, use the command given below to make a specified segment changeable (if no segment is specified, then the segment to be worked on at the time of executing the command involved). After changing the parameters, send the “SDON” command to finish changing segments.

- “SEDI” on page 421



### Deleting a segment

To delete a segment, use the commands given below.

- “SDEL” on page 412
- “CLEL” on page 271

The “SDEL” command deletes a specified segment from the table (if no table is specified, then the segment to be worked on at the time of executing the command involved). The “CLEL” command deletes all segments from the table.

### Setting the trace color of each segment

To specify the trace color of each segment, use the command given below.

- “SCOL” on page 411

## Setting the Limit Test Functions

To turn on or off the limit test functions, use the command given below.

- “LIMITEST” on page 317

To use the limit test functions, you need to make a limit line table, which includes the limits of sweep ranges (segments) defined by start points and endpoints. When beginning and finishing a table, send the commands given below.

- “EDITLIML” on page 300
- “LIMEDONE” on page 315

---

### NOTE

With the “LIMEDONE” command not executed, the settings resulting from making, editing, and deleting with the commands given below will not take effect, and the limit line table is left as it was before execution of the “EDITLIML” command.

---

## Making/editing a segment

To make a new segment, use the command given below. This command adds a segment that is ready to be edited.

- “LIMSADD” on page 319

To set a segment's range (its start point and end point), use the commands given below.

- “LIMSTAR” on page 323
- “MKRLIMSTAR” on page 342
- “LIMSTOP” on page 325
- “MKRLIMSTOP” on page 342

To set a range for limiting start points, use the commands given below.

- “LIMUSTAR” on page 326
- “LIMLSTAR” on page 317
- “LIMVSTAR” on page 328
- “MKRLIMVSTAR” on page 343
- “LIMDSTAR” on page 314

To set a range for limiting endpoints, use the commands given below.

- “LIMUSTOP” on page 327
- “LIMLSTOP” on page 318
- “LIMVSTOP” on page 329
- “MKRLIMVSTOP” on page 343
- “LIMDSTOP” on page 315

To turn on or off the ranges for limiting individual segments, use the command given below.

- “LIMSTEST” on page 324

After setting the parameters, send the command given below to finish setting segments.

- “LIMSDON” on page 320

Each segment is assigned a segment number (a row number in the limit line table) for specifying the segment to be set, changed, or deleted. To specify the number of the segment to be worked on, use the command given below.

- “LIMSEGM” on page 322

Executing the “LIMSADD” command makes an additional insertion under the line of a specified segment (if no segment is specified, then the segment to be worked on at the time of executing the command involved), and the added segment becomes the target of setting. Thus you don't need to specify segment numbers when using the “LIMSADD” command to make a new table by adding segments in the intended sequence. You only need to specify a segment number only when adding a new segment at an arbitrary position of an existing table.

To change the parameters settings of existing segments, use the command given below to make a specified segment changeable (if no segment is specified, then the segment to be worked on at the time of executing the command involved). After changing the parameters, send the “LIMSDON” command to finish changing the segments.

- “LIMSEDI” on page 321

### Deleting a segment

To delete a segment, use the commands given below.

- “LIMSDEL” on page 320
- “LIMCLEL” on page 313

The “LIMSDEL” command deletes a specified segment (if no segment is specified, then the segment to be worked on at the time of executing the command involved) from the limit line table. The “LIMCLEL” command deletes all of the segments included in the limit line table.

### Moving offset ranges

To move limit lines that define a range in parallel, you can set an offset distance for any range among all of the segments by using the commands given below.

- “LIMIAMPO” on page 316
- “LIMIPRMO” on page 316

## **Saving/Recalling Measurement Conditions**

You can save the measurement conditions in a file. By saving frequently used measurement conditions, you can set the Agilent 4294A to a desired measurement condition by merely recalling the corresponding file when needed, avoiding the need to send a number of commands. To save or recall measurement conditions, use the commands given below. See Chapter 8, “Saving/Recalling a Measurement Result/Measurement Setup,” for details of saving/recalling.

- “SAVDSTA” on page 406
- “RECD” on page 395

## A Sample Program for Setting Measurement Conditions

The following is a sample program for setting measurement conditions. The program is given the file name setup.bas and stored on the sample program disk.

This program resets the Agilent 4294A, then makes the settings shown below, and finally delivers the completion message when the settings are completed.

Item		Setting
Adaptor setting		No adaptor
Measurement parameter		A: Impedance amplitude B: Impedance phase
Limit of dc bias output		15 V
dc bias range		10 mA range
Type of sweep		List sweep (refer to a separate table)
How to indicate list sweeps		Segment by segment
Separation of trace A and trace B		Turned on
Whether to lay a trace over another		Turned on
Trace A	Trace to be displayed	DATA
	Display format	Log Y axis format
	The maximum value to be displayed on the screen	1E-3
	The minimum value to be displayed on the screen	1E-9
Trace B	Trace to be displayed	DATA
	Display format	Linear Y axis format
	Position of the grid's reference line	5
	Value of the grid's reference line	0
	Value for one graduation of the grid	72
	Unit of indicating a phase	° (degrees)
	Whether to turn on of off the extended phase indication	Turned on

Setting in the list sweep table	Segment 1	Segment 2	Segment 3
Start frequency	1 MHz	20 MHz	40 MHz
Stop frequency	20 MHz	40 MHz	100 MHz
Number of measurement points	21	51	21
Oscillator output setting mode	In voltage	In voltage	In voltage
Oscillator output level	1 V	1 V	1 V
dc bias output mode	Constant voltage	Constant voltage	Constant voltage
dc bias output level	10 V	10 V	10 V
Measurement bandwidth	Bandwidth 1	Bandwidth 5	Bandwidth 1
Number of points used in averaging	1	4	1
Trace color	Pen 1	Pen 2	Pen 3

## Setting Measurement Conditions

### A Sample Program for Setting Measurement Conditions

Lines 90 to 130	These lines distinguish between an external controller and the Instrument BASIC and set the GPIB address.
Lines 150 to 180	These lines substitute the settings of adapter selection, measurement parameters, and limits of dc bias output and of dc bias range to the variables Adapter\$, Meas_para\$, Dc_b_max, Dc_b_rng\$, respectively.
Lines 220 to 500	These lines substitute the parameter settings necessary for making a list sweep table to the variables List_star(*), List_stop(*), Nop(*), Osc_mode\$(*), Osc_pow(*), Dc_b_mode\$(*), Dc_bias(*), Bw_fact\$(*), and P_ave(*) .
Lines 540 to 680	These line substitute the display-related parameter settings to the variables Split\$, Accumulate\$, Disp_a\$, Disp_b\$, Fmt_a\$, Fmt_b\$, Top_v_a, Btm_v_a, Ref_p_b, Ref_v_b, Scal_b, Phase_unit\$, and Exp_phase\$.
Lines 700 to 710	These lines reset the Agilent 4294A and then set the adapter selection to the variable Adapter\$.
Lines 750 to 900	These lines make a list sweep table.
Lines 920 to 970	These lines set the measurement parameter to Meas_para\$, limit of dc bias output to Dc_b_max, dc bias range to Dc_b_rng\$, On/Off setting of dc bias to On and set the type of sweep to List Sweep and the display format to Segment By Segment.
Lines 980 to 990	These lines set the display parameters common to traces A and B.
Lines 1030 to 1070	These lines set the display parameters of trace A.
Lines 1110 to 1180	These lines set the display parameters of trace B.
Lines 1200 to 1230	These lines wait for execution of the commands used to make settings, indicate the message of completion, and end the program.

#### Example 3-1

#### Setting measurement conditions

```
10 DIM Adapter$(9),Meas_para$(5),Dc_b_rng$(9),Buff$(9)
20 DIM Osc_mode$(1:3)(9),Dc_b_mode$(1:3)(9),Bw_fact$(1:3)(9)
30 DIM Split$(9),Accumulate$(9),Disp_a$(9),Disp_b$(9)
40 DIM Fmt_a$(9),Fmt_b$(9),Phase_unit$(9),Exp_phase$(9)
50 REAL List_star(1:3),List_stop(1:3),Osc_pow(1:3),Dc_bias(1:3)
60 REAL Dc_b_max,Top_v_a,Btm_v_a,Ref_v_b,Scal_b
70 INTEGER Nop(1:3),P_ave(1:3),Ref_p_b
80 !
90 IF SYSTEM$("SYSTEM ID")="HP4294A" THEN
100 ASSIGN @Hp4294a TO 800
110 ELSE
120 ASSIGN @Hp4294a TO 717
130 END IF
140 !
150 Adapter$="OFF"
160 Meas_para$="IMPH"
170 Dc_b_max=15.0
180 Dc_b_rng$="M10"
190 !
200 ! List Sweep Table
210 ! -- Segment 1 --
```

## Setting Measurement Conditions A Sample Program for Setting Measurement Conditions

```
220 List_star(1)=1.0E+6
230 List_stop(1)=2.0E+7
240 Nop(1)=21
250 Osc_mode$(1)="VOLT"
260 Osc_pow(1)=1.0
270 Dc_b_mode$(1)="CVOLT"
280 Dc_bias(1)=10.0
290 Bw_fact$(1)="1"
300 P_ave(1)=1
310 ! -- Segment 2 --
320 List_star(2)=2.0E+7
330 List_stop(2)=4.0E+7
340 Nop(2)=51
350 Osc_mode$(2)="VOLT"
360 Osc_pow(2)=1.0
370 Dc_b_mode$(2)="CVOLT"
380 Dc_bias(2)=10.0
390 Bw_fact$(2)="5"
400 P_ave(2)=4
410 ! -- Segment 3 --
420 List_star(3)=4.0E+7
430 List_stop(3)=1.0E+8
440 Nop(3)=21
450 Osc_mode$(3)="VOLT"
460 Osc_pow(3)=1.0
470 Dc_b_mode$(3)="CVOLT"
480 Dc_bias(3)=10.0
490 Bw_fact$(3)="1"
500 P_ave(3)=1
510 !
520 ! Display Setting
530 !
540 Split$="ON"
550 Accumulate$="ON"
560 ! -- Trace A --
570 Disp_a$="DATA"
580 Fmt_a$="LOGY"
590 Top_v_a=1.0E-3
600 Btm_v_a=1.0E-9
610 ! -- Trace B --
620 Disp_b$="DATA"
630 Fmt_b$="LINY"
640 Ref_p_b=5
650 Ref_v_b=0.
660 Scal_b=72.0
670 Phase_unit$="DEG"
680 Exp_phase$="ON"
690 !
700 OUTPUT @Hp4294a;"PRES"
710 OUTPUT @Hp4294a;"E4TP "&Adapter$
720 !
730 ! List Sweep Tabel Edit
740 !
750 OUTPUT @Hp4294a;"EDITLIST"
760 FOR I=1 TO 3
770     OUTPUT @Hp4294a;"SADD"
780     OUTPUT @Hp4294a;"STAR ";List_star(I)
790     OUTPUT @Hp4294a;"STOP ";List_stop(I)
```

## Setting Measurement Conditions

### A Sample Program for Setting Measurement Conditions

```
800     OUTPUT @Hp4294a;"POIN ";Nop(I)
810     OUTPUT @Hp4294a;"POWMOD "&Osc_mode$(I)
820     OUTPUT @Hp4294a;"POWE ";Osc_pow(I)
830     OUTPUT @Hp4294a;"DCMOD "&Dc_b_mode$(I)
840     OUTPUT @Hp4294a;"DCV ";Dc_bias(I)
850     OUTPUT @Hp4294a;"BWFACT "&Bw_fact$(I)
860     OUTPUT @Hp4294a;"PAVERFACT ";P_ave(I)
870     OUTPUT @Hp4294a;"SDON"
880     OUTPUT @Hp4294a;"SCOL ";((I-1) MOD 6)+1
890     NEXT I
900     OUTPUT @Hp4294a;"EDITDONE"
910     !
920     OUTPUT @Hp4294a;"MEAS "&Meas_para$
930     OUTPUT @Hp4294a;"MAXDCV ";Dc_b_max
940     OUTPUT @Hp4294a;"DCRNG "&Dc_b_rng$
950     OUTPUT @Hp4294a;"DCO ON"
960     OUTPUT @Hp4294a;"SWPT LIST"
970     OUTPUT @Hp4294a;"LISPAN SEGMENT"
980     OUTPUT @Hp4294a;"SPLD "&Split$
990     OUTPUT @Hp4294a;"ACCUD "&Accumulate$
1000    !
1010    ! Trace A Setting
1020    !
1030    OUTPUT @Hp4294a;"TRAC A"
1040    OUTPUT @Hp4294a;"DISP "&Disp_a$
1050    OUTPUT @Hp4294a;"FMT "&Fmt_a$
1060    OUTPUT @Hp4294a;"TOPV ";Top_v_a
1070    OUTPUT @Hp4294a;"BOTV ";Btm_v_a
1080    !
1090    ! Trace B Setting
1100    !
1110    OUTPUT @Hp4294a;"TRAC B"
1120    OUTPUT @Hp4294a;"DISP "&Disp_b$
1130    OUTPUT @Hp4294a;"FMT "&Fmt_b$
1140    OUTPUT @Hp4294a;"REFP ";Ref_p_b
1150    OUTPUT @Hp4294a;"REFV ";Ref_v_b
1160    OUTPUT @Hp4294a;"SCAL ";Scal_b
1170    OUTPUT @Hp4294a;"PHAU "&Phase_unit$
1180    OUTPUT @Hp4294a;"EXPP "&Exp_phase$
1190    !
1200    OUTPUT @Hp4294a;"*OPC?"
1210    ENTER @Hp4294a;Buff$
1220    PRINT "Measurement Condition Setup Complete"
1230    END
```



---

**4**

## **Preparing For Accurate Measurement**

This chapter describes how to apply adapter setting, user calibration, fixture compensation, and port extension compensation.

---

## Adapter Setting

To select an adapter, use the command given below.

- “E4TP” on page 299

If you select any adapter other than NONE, you need to measure the data indicated in the table below to calculate the setup data.

Adapter	Phase	Open	Short	Load
NONE	Unnecessary	Unnecessary	Unnecessary	Unnecessary
4TP 1M	Necessary	Unnecessary	Unnecessary	Necessary
4TP 2M	Necessary	Unnecessary	Unnecessary	Necessary
7mm 42942A	Necessary	Necessary	Necessary	Necessary
PROBE 42941A	Necessary	Necessary	Necessary	Necessary

To measure data, use the command given below.

- “ECAL {P|A|B|C}” on page 299

After measuring the necessary data, execute the command given below to calculate the setup data for the selected adapter and then store this in the nonvolatile memory (EEPROM).

- “ECALDON” on page 299

---

### NOTE

If you execute the “ECAL {P|A|B|C}” command to measure unnecessary data, an error occurs and the command is ignored.

To suspend the above process, execute the command given below.

- “ECALQUI” on page 300

A sample program for adapter setting is shown in Example 4-1. This program is given the file name adapter.bas and is stored on the sample program disk.

This program selects 7mm 42942A for adapter setting, measures phase data, open data, short data and load data and then stores them in nonvolatile memory.

Lines 40 to 100     These lines distinguish between the external controller and Instrument BASIC and set the GPIB address and the select code.

Line 110            This line substitutes the adapter selection to the variable Adapter\$.

Lines 130 to 160   These lines reset the Agilent 4294A and then set the adapter selection to the variable Adapter\$.

Lines 180 to 190   These lines set 1 to Bit 8 of the instrument event status register (the bit for completion of the measurement of calibration data and compensation data) and to Bit 2 of the service request enable register so that SRQ can be used.

- Lines 210 to 310 These lines measure phase data, open data, short data and load data by using the subprogram FNAdap\_setup. If an error is detected after any measurement, the program is terminated.
- Lines 330 to 350 These lines calculate setup data and store them in non-volatile memory.
- Lines 360 to 380 These lines indicate the message of completion and terminate the program.

The following describes FNAdap\_setup, a data measurement subprogram for calculating setup data, which is shown in lines 420 to 800.

- Line 450 This line clears the status byte register.
- Lines 460 to 470 These lines prompt for the connection of the standard for measurement specified by Standard\$ and wait for you to press the y key and the return key.
- Lines 490 to 500 These lines set the branch target for an SRQ interrupt to make the SRQ interrupt effective.
- Lines 510 to 600 These lines send the commands to execute the measurement specified by Standard\$.
- Line 620 This line waits for measurement to finish.
- Lines 640 to 740 These lines check whether an error has occurred during measurement. If no error occurred, then these lines indicate the message of measurement completion and return a 0 as the return value from the subprogram. If an error occurred, then these lines indicate an error message, execute the command that suspends data measurement, and return -1 as the return value from the subprogram.
- Lines 760 to 780 These lines are steps for any key other than the y key pressed in response to line 470. These lines execute the command that suspends data measurement and then return -1 as the return value from the subprogram.

**Example 4-1**

**Data measurement for adapter setting**

```

10 DIM Adapter$(9),Buff$(9)
20 INTEGER Scode,Result
30 CLEAR SCREEN
40 IF SYSTEM$("SYSTEM ID")="HP4294A" THEN
50     ASSIGN @Hp4294a TO 800
60     Scode=8
70 ELSE
80     ASSIGN @Hp4294a TO 717
90     Scode=7
100 END IF
110 Adapter$="APC7"
120 !
130 OUTPUT @Hp4294a;"PRES"
140 OUTPUT @Hp4294a;"*OPC?"
150 ENTER @Hp4294a;Buff$
160 OUTPUT @Hp4294a;"E4TP "&Adapter$
170 !
180 OUTPUT @Hp4294a;"ESNB 256"
190 OUTPUT @Hp4294a;"*SRE 4"

```

## Preparing For Accurate Measurement Adapter Setting

```
200      !
210      Result=FNAdap_setup(@Hp4294a,Scode,"Phase")
220      IF Result<>0 THEN Prog_end
230      !
240      Result=FNAdap_setup(@Hp4294a,Scode,"Open")
250      IF Result<>0 THEN Prog_end
260      !
270      Result=FNAdap_setup(@Hp4294a,Scode,"Short")
280      IF Result<>0 THEN Prog_end
290      !
300      Result=FNAdap_setup(@Hp4294a,Scode,"Load")
310      IF Result<>0 THEN Prog_end
320      !
330      OUTPUT @Hp4294a;"ECALDON"
340      OUTPUT @Hp4294a;"*OPC?"
350      ENTER @Hp4294a;Buff$
360      PRINT "All Data Measurement Complete"
370      !
380 Prog_end: END
390      !
400      ! Adapter Setup Data Measurement Function
410      !
420 DEF FNAdap_setup(@Hp4294a,INTEGER Scode,Standard$)
430   DIM Inp_char$[9],Err_mes$[50]
440   INTEGER Err_no
450   OUTPUT @Hp4294a;"*CLS"
460   PRINT "Set "&Standard$&"-Connection"
470   INPUT "OK? [Y/N]",Inp_char$
480   IF UPC$(Inp_char$)="Y" THEN
490     ON INTR Scode GOTO Meas_end
500     ENABLE INTR Scode;2
510     SELECT Standard$
520       CASE "Phase"
530         OUTPUT @Hp4294a;"ECALP"
540       CASE "Open"
550         OUTPUT @Hp4294a;"ECALA"
560       CASE "Short"
570         OUTPUT @Hp4294a;"ECALB"
580       CASE "Load"
590         OUTPUT @Hp4294a;"ECALC"
600     END SELECT
610     PRINT "Now measuring..."
620 Meas_wait: GOTO Meas_wait
630 Meas_end:  !
640     OUTPUT @Hp4294a;"OUTPERRO?"
650     ENTER @Hp4294a;Err_no,Err_mes$
660     IF Err_no=0 THEN
670       PRINT Standard$&" Data Measurement Complete"
680       RETURN 0
690     ELSE
700       PRINT "Error: "&Err_mes$
710       PRINT "Program Interruption"
720       OUTPUT @Hp4294a;"ECALQUI"
730       RETURN -1
740     END IF
750   ELSE
760     PRINT "Program Interruption"
770     OUTPUT @Hp4294a;"ECALQUI"
```

```
780     RETURN -1  
790     END IF  
800 FNEND
```

## User Calibration

Selecting either 7mm or PROBE while setting the adapter allows you to use the user calibration functions. To turn the user calibration functions on or off, use the command given below. If no user calibration coefficients have been retained, the user calibration functions cannot be turned on.

- “CALST” on page 268

To measure open data, short data and load data for calculating the user calibration coefficients, use the command given below.

- “CAL{A|B|C}” on page 266

---

### NOTE

User calibration data and fixture compensation data are measured either at fixed points preset by the Agilent 4294A (fixed measurement points) or at sweep measurement points set at the time of command execution (user measurement points). In the former case, the compensation coefficient at a sweep measurement point is obtained by interpolation. To select points for measuring data, use the “CALP” command on page 267.

To set standard values to be used in measuring these data, use the commands given below.

- “DCALOPEN{G|C}” on page 279
- “DCALSHOR{R|L}” on page 280
- “DCALLOAD{R|L}” on page 278

After measuring individual data, execute the command given below to calculate the user calibration coefficient and to store it in volatile memory (RAM).

- “CALDON” on page 266

---

### NOTE

To calculate the user calibration coefficient, all of the open data, short data and load data are required. If you execute this command before measurement of the data is fully completed, an error occurs and the command is ignored.

To suspend the above process, execute the command given below.

- “CALQUI” on page 267

To read measured open data, short data or load data, use the command given below.

- “OUTPCALC{1-3}?” on page 362

You can calculate the user calibration coefficients by entering open data, short data and load data (data read by the above or a similar command). To enter data, use the command given below.

- “INPUCALC{1-3}” on page 309

---

**NOTE** Enter data after setting the standard values used in measuring the data because these values are needed to calculate user calibration coefficients.

---



---

**NOTE** To use the input data, you need to enter all of the open data, short data and load data. At the instant when all the data are entered, the calibration coefficient is automatically calculated and stored in volatile memory. Therefore, you don't need to execute the “CALDON” command if you enter all the data.

---



---

**NOTE** Enter data after making settings identical to the data measurement points (fixed measurement points, user-selected measurement points) set at the time when the input data were acquired. In addition, in the case of user-selected measurement points, enter data after making sweep settings identical to the data measurement points.

---

Example 4-2 shows a sample program for measuring data to be used for calculating a user calibration coefficient. This program is given the file name user\_cal.bas and is stored on the sample program disk.

After you enter standard values for open data, short data and load data, this program measures open data, short data and load data, calculates the user calibration coefficient, and stores it in volatile memory.

- |                  |   |
|------------------|---|
| Lines 50 to 110  | These lines distinguish between the external controller and Instrument BASIC and set the GPIB address and the select code.  |
| Line 120         | This line substitutes the selection of data measurement points to the variable Cal_point\$.   |
| Lines 160 to 190 | These lines reset the Agilent 4294A and then set data measurement points to Cal_point\$.  |
| Lines 230 to 280 | These lines use the subprogram Inp_data to acquire standard values for open data, short data, and load data.  |
| Lines 290 to 340 | These lines prepare the standard values you entered for subsequent use. The open standard capacitance needs to be in femtofarad, so these lines make necessary conversion.  |
| Lines 380 to 390 | These lines set 1 to Bit 8 of the instrument event status register (the bit for the completion of the measurement of calibration data and compensation data) and to Bit 2 of the service request enable register so that SRQ can be used. |
| Lines 410 to 480 | These lines measure open data, short data and load data by using the subprogram FNUser_cal. If an error is detected after any measurement, the program is terminated.   |
| Lines 500 to 520 | These lines calculate the user calibration coefficient and store it in  |

## Preparing For Accurate Measurement User Calibration

volatile memory.

Lines 530 to 540 These lines indicate the message of completion and terminate the program.

The following describes FNUser\_cal, a data measurement subprogram for user calibration, which is shown in lines 580 to 920.

Line 610 This line clears the status byte register.

Lines 620 to 630 These lines prompt for the connection of the standard for measurement specified by Standard\$ and wait for you to press the y key and the return key.

Lines 650 to 660 These lines set the branch target for an SRQ interrupt to make the SRQ interrupt effective.

Lines 670 to 740 These lines send the commands to execute the standard measurement specified by Standard\$.

Line 760 This line waits for the measurement to finish.

Lines 780 to 880 These lines check whether an error has occurred during measurement. If no error occurred, then these lines indicate the message of measurement completion and return 0 as the return value from the subprogram. If an error occurred, then these lines indicate an error message, execute the command that suspends data measurement, and return -1 as the return value from the subprogram.

Lines 900 to 920 These lines are steps for any key other than the y key pressed in response to line 630. These lines execute the command that suspends data measurement and then return -1 as the return value from the subprogram.

The following describes the subprogram Inp\_data for entering the data shown in lines 980 to 1090.

Line 1000 This line returns to the start line of input if an error occurs due to an invalid input or similar reason. This allows you to make entries again.

Lines 1020 to 1030 These lines prompt you to enter a data item specified by Mes\$ and wait for you to enter it.

Lines 1040 to 1060 These lines indicate the value entered and wait for you to press either the y key or the n key to notify whether the input is correct or not.

Line 1070 This line returns to the start line of input if any key other than the y key is pressed in response to line 1060.



**Example 4-2 Data measurement for user calibration**

```

10   DIM Input_val$(9),Buff$(9),Adapter$(9)
20   REAL Open_g,Open_c,Short_r,Short_l,Load_r,Load_l
30   INTEGER Scode,Err_no
40   CLEAR SCREEN
50   IF SYSTEM$("SYSTEM ID")="HP4294A" THEN
60       ASSIGN @Hp4294a TO 800
70       Scode=8
80   ELSE
90       ASSIGN @Hp4294a TO 717
100      Scode=7
110   END IF
120   Cal_point$="USER"
130   !
140   ! Initial Setting
150   !
160   OUTPUT @Hp4294a;"PRES"
170   OUTPUT @Hp4294a;"*OPC?"
180   ENTER @Hp4294a;Buff$
190   OUTPUT @Hp4294a;"CALP ";Cal_point$
200   !
210   ! Entry Standard Value
220   !
230   CALL Inp_data("Open(G)",Open_g)
240   CALL Inp_data("Open(C)",Open_c)
250   CALL Inp_data("Short(R)",Short_r)
260   CALL Inp_data("Short(L)",Short_l)
270   CALL Inp_data("Load(R)",Load_r)
280   CALL Inp_data("Load(L)",Load_l)
290   OUTPUT @Hp4294a;"DCALOPENG ";Open_g
300   OUTPUT @Hp4294a;"DCALOPENC ";Open_c/1.E-15
310   OUTPUT @Hp4294a;"DCALSHORR ";Short_r
320   OUTPUT @Hp4294a;"DCALSHORL ";Short_l
330   OUTPUT @Hp4294a;"DCALLOADR ";Load_r
340   OUTPUT @Hp4294a;"DCALLOADL ";Load_l
350   !
360   ! Data Measurement
370   !
380   OUTPUT @Hp4294a;"ESNB 256"
390   OUTPUT @Hp4294a;"*SRE 4"
400   !
410   Result=FNUser_cal(@Hp4294a,Scode,"Open")
420   IF Result<>0 THEN Prog_end
430   !
440   Result=FNUser_cal(@Hp4294a,Scode,"Short")
450   IF Result<>0 THEN Prog_end
460   !
470   Result=FNUser_cal(@Hp4294a,Scode,"Load")
480   IF Result<>0 THEN Prog_end
490   !
500   OUTPUT @Hp4294a;"CALDON"
510   OUTPUT @Hp4294a;"*OPC?"
520   ENTER @Hp4294a;Buff$
530   PRINT "All Data Measurement Complete"
540 Prog_end: END
550   !

```

## Preparing For Accurate Measurement User Calibration

```
560     ! User Calibration Data Measurement Function
570     !
580 DEF FNUser_cal (@Hp4294a, INTEGER Scode, Standard$)
590   DIM Inp_char$(9), Err_mes$(50)
600   INTEGER Err_no
610   OUTPUT @Hp4294a; "*CLS"
620   PRINT "Set "&Standard$&"-Connection"
630   INPUT "OK? [Y/N]", Inp_char$
640   IF UPC$(Inp_char$)="Y" THEN
650     ON INTR Scode GOTO Meas_end
660     ENABLE INTR Scode;2
670     SELECT Standard$
680       CASE "Open"
690         OUTPUT @Hp4294a;"CALA"
700       CASE "Short"
710         OUTPUT @Hp4294a;"CALB"
720       CASE "Load"
730         OUTPUT @Hp4294a;"CALC"
740     END SELECT
750     PRINT "Now measuring..."
760 Meas_wait: GOTO Meas_wait
770 Meas_end:  !
780     OUTPUT @Hp4294a;"OUTPERRO?"
790     ENTER @Hp4294a;Err_no,Err_mes$
800     IF Err_no=0 THEN
810       PRINT Standard$&" Data Measurement Complete"
820       RETURN 0
830     ELSE
840       PRINT "Error: "&Err_mes$
850       PRINT "Program Interruption"
860       OUTPUT @Hp4294a;"CALQUI"
870       RETURN -1
880     END IF
890   ELSE
900     PRINT "Program Interruption"
910     OUTPUT @Hp4294a;"CALQUI"
920     RETURN -1
930   END IF
940 FNEND
950   !
960   ! Data Input Function
970   !
980 SUB Inp_data (Mes$, Inp_val)
990   DIM Inp_char$(30)
1000  ON ERROR GOTO Inp_start
1010 Inp_start: !
1020  PRINT "Input "&Mes$
1030  INPUT "Value?", Inp_char$
1040  Inp_val=VAL(UPC$(Inp_char$))
1050  PRINT "Input value: ";Inp_val
1060  INPUT "OK? [Y/N]", Inp_char$
1070  IF UPC$(Inp_char$)<>"Y" THEN Inp_start
1080  OFF ERROR
1090 SUBEND
```

## Fixture Compensation

To turn on or off the open/short/load compensation of the fixture compensation functions, use the command given below. You can set open/short/load compensations independently. However, if no compensation coefficients are retained, the functions cannot be turned on.

- “COMST{A|B|C}” on page 274

To measure open data, short data and load data for calculating compensation coefficients in open/short/load compensation of the fixture compensation functions, use the commands given below. Executing these commands calculates fixture compensation coefficients of measured data and stores them in volatile memory (RAM). In addition, the compensation function for measured data is turned on.

- “COM{A|B|C}” on page 273

---

### NOTE

User calibration data and fixture compensation data are measured either at fixed points preset by the Agilent 4294A (fixed measurement points) or at sweep measurement points set at the time of command execution (user-selected measurement points). In the case of the former, the compensation coefficient at a sweep measurement point is obtained by interpolation. To select points for measuring data, use the “CALP” command on page 267.

To set standard values to be used in measuring these data, use the commands given below.

- “DCOMOPEN{G|C}” on page 283
- “DCOMSHOR{R|L}” on page 284
- “DCOMLOAD{R|L}” on page 282

To read open data, short data or load data measured, use the command given below.

- “OUTPCOMC{1-3}?” on page 363

You can calculate fixture compensation coefficients by entering open data, short data and load data (data read by the above or similar command). To enter data, use the command given below. Executing these commands calculates the fixture compensation coefficients of measured data and stores them in volatile memory (RAM). In addition, the compensation function for measured data is turned on.

- “INPUCOMC{1-3}” on page 310

---

### NOTE

Enter data after setting the standard values used in measuring the data because these values are needed to calculate fixture compensation coefficients.

---

### NOTE

Enter data after making settings identical to the data measurement points (fixed measurement points, user-selected measurement points) set at the time when the input data were acquired. In addition, in the case of the user-selected measurement points, enter data after making the sweep settings identical to the data measurement points.

## Preparing For Accurate Measurement Fixture Compensation

Example 4-3 shows a sample program for measuring data to be used for calculating a fixture compensation coefficient. This program is given the file name `com_meas.bas` and is stored on the sample program disk.

Enter standard values for open data, short data and load data. This program then measures open data, short data and load data at fixed measurement points preset by the Agilent 4294A and stores the measured data and the defined standard values in a flash disk (nonvolatile memory disk) by giving the data the filenames `COM_DATA` and `STD_VAL`, respectively.

- |                  |  |
|------------------|--|
| Lines 60 to 150  | These lines distinguish between the external controller and Instrument BASIC and set the GPIB address and select code. In the case of Instrument BASIC, flash memory is used as the storage unit.  |
| Lines 160 to 180 | These lines substitute the selection of data measurement points to the variable <code>Cal_point\$</code> , the name of the file to be retained measured data to the variable <code>File\$</code> , and the name of the file to be retained as standard value to the variable <code>Std_file\$</code> . |
| Lines 220 to 250 | These lines reset the Agilent 4294A and then substitutes the data measurement points to <code>Cal_point\$</code> .   |
| Lines 290 to 340 | These lines use the subprogram <code>Inp_data</code> to acquire standard values to enter open data, short data and load data.  |
| Lines 350 to 400 | These lines set the standard values. The open standard capacitance needs to be in femtofarad, so these lines make the necessary conversion.  |
| Lines 440 to 450 | These lines set 1 to Bit 8 of the instrument event status register (the bit for the completion of the measurement of calibration data and compensation data) and to Bit 2 of the service request enable register so that SRQ can be used.  |
| Lines 470 to 540 | These lines measure open data, short data and load data by using the subprogram <code>FNFixt_comp</code> . If an error is detected after any measurement, the program is terminated.   |
| Lines 580 to 740 | These lines select the IEEE 64-bit floating-point format for the data transfer format, read open data, short data and load data to store them in the arrays <code>Com_o(*)</code> , <code>Com_s(*)</code> , and <code>Com_l(*)</code> , respectively.  |
| Lines 790 to 810 | These lines delete a file named <code>File\$</code> if already exists.   |
| Lines 830 to 860 | This lines create a file named <code>File\$</code> and write the data stored in the arrays <code>Com_o(*)</code> , <code>Com_s(*)</code> , <code>Com_l(*)</code> to that file.   |
| Lines 880 to 900 | These lines delete a file named <code>Std_file\$</code> if already exists.   |
| Lines 910 to 950 | This lines create a file named <code>File\$</code> and write the open/short/load standard values.  |
| Lines 970 to 980 | These lines indicate the message of completion and terminate the program.  |

The following describes `FNFixt_comp`, a data measurement subprogram for fixture compensation, which is shown in lines 1020 to 1280.

Line 1050            This line clears the status byte register.

Lines 1060 to 1070    These lines prompt the connection for the measurement specified by

Standard\$ and wait for you to press the y key and the return key.

Lines 1090 to 1100 These lines set the branch target for an SRQ interrupt to make the SRQ interrupt effective.

Lines 1110 to 1180 These lines send the commands to execute the standard measurement specified by Standard\$.

Line 1200 This line waits for measurement to finish.

Lines 1220 to 1230 These lines indicate the message of measurement completion and return 0 as the return value from the sub-program.

Lines 1250 to 1260 These lines are steps for any key other than the y key pressed in response to line 970. These lines return -1 as the return value from the sub-program.

See Example 4-2 on page 61 for the subprogram Inp\_data.

### Example 4-3

#### Date measurement for fixture compensation

```

10    DIM Adapter$(9),Buff$(9),File$(20),Std_file$(20),Cal_point$(9),
Size$(9)
20    DIM Com_o(1:100,1:2),Com_s(1:100,1:2),Com_l(1:100,1:2)
30    REAL Open_g,Open_c,Short_r,Short_l,Load_r,Load_l
40    INTEGER Result,Scode
50    CLEAR SCREEN
60    IF SYSTEM$("SYSTEM ID")="HP4294A" THEN
70        ASSIGN @Hp4294a TO 800
80        ASSIGN @Binary TO 800;FORMAT OFF
90        MASS STORAGE IS ":INTERNAL1,5"
100       Scode=8
110    ELSE
120       ASSIGN @Hp4294a TO 717
130       ASSIGN @Binary TO 717;FORMAT OFF
140       Scode=7
150    END IF
160    Cal_point$="FIXED"
170    File$="COM_DATA"
180    Std_file$="STD_VAL"
190    !
200    ! Initial Setting
210    !
220    OUTPUT @Hp4294a;"PRES"
230    OUTPUT @Hp4294a;"*OPC?"
240    ENTER @Hp4294a;Buff$
250    OUTPUT @Hp4294a;"CALP ";Cal_point$
260    !
270    ! Entry Standard Value
280    !
290    CALL Inp_data("Open(G)",Open_g)
300    CALL Inp_data("Open(C)",Open_c)
310    CALL Inp_data("Short(R)",Short_r)
320    CALL Inp_data("Short(L)",Short_l)
330    CALL Inp_data("Load(R)",Load_r)
340    CALL Inp_data("Load(L)",Load_l)
350    OUTPUT @Hp4294a;"DCOMOPENG ";Open_g
360    OUTPUT @Hp4294a;"DCOMOPENC ";Open_c/1.E-15
370    OUTPUT @Hp4294a;"DCOMSHORR ";Short_r
380    OUTPUT @Hp4294a;"DCOMSHORL ";Short_l
390    OUTPUT @Hp4294a;"DCOMLOADR ";Load_r
400    OUTPUT @Hp4294a;"DCOMLOADL ";Load_l
410    !
420    ! Data Measurement
430    !

```

## Preparing For Accurate Measurement Fixture Compensation

```
440 OUTPUT @Hp4294a;"ESNB 256"
450 OUTPUT @Hp4294a;"*SRE 4"
460 !
470 Result=FNFixt_comp(@Hp4294a,Scode,"Open")
480 IF Result<>0 THEN Prog_end
490 !
500 Result=FNFixt_comp(@Hp4294a,Scode,"Short")
510 IF Result<>0 THEN Prog_end
520 !
530 Result=FNFixt_comp(@Hp4294a,Scode,"Load")
540 IF Result<>0 THEN Prog_end
550 !
560 ! Data Reading
570 !
580 OUTPUT @Hp4294a;"FORM3"
590 !
600 OUTPUT @Hp4294a;"OUTPCOMC1?"
610 ENTER @Hp4294a USING "#,2A";Buff$
620 ENTER @Hp4294a USING "#,6A";Size$
630 ENTER @Binary;Com_o(*)
640 ENTER @Hp4294a USING "#,1A";Buff$
650 !
660 OUTPUT @Hp4294a;"OUTPCOMC2?"
670 ENTER @Hp4294a USING "#,8A";Buff$
680 ENTER @Binary;Com_s(*)
690 ENTER @Hp4294a USING "#,1A";Buff$
700 !
710 OUTPUT @Hp4294a;"OUTPCOMC3?"
720 ENTER @Hp4294a USING "#,8A";Buff$
730 ENTER @Binary;Com_l(*)
740 ENTER @Hp4294a USING "#,1A";Buff$
750 !
760 ! Data Saving
770 !
780 Data_size=VAL(Size$)*3
790 ON ERROR GOTO Skip_purge1
800 PURGE File$
810 Skip_purge1: OFF ERROR
820 PRINT "Compensation Data Save file: "&File$
830 CREATE File$,Data_size
840 ASSIGN @File TO File$;FORMAT OFF
850 OUTPUT @File;Com_o(*),Com_s(*),Com_l(*)
860 ASSIGN @File TO *
870 !
880 ON ERROR GOTO Skip_purge2
890 PURGE Std_file$
900 Skip_purge2: OFF ERROR
910 PRINT "Standard Value Save file: "&Std_file$
920 CREATE Std_file$,48
930 ASSIGN @File TO Std_file$;FORMAT OFF
940 OUTPUT @File;Open_g,Open_c,Short_r,Short_l,Load_r,Load_l
950 ASSIGN @File TO *
960 !
970 PRINT "All Data Measurement Complete"
980 Prog_end: END
990 !
1000 ! Fixture Compensation Data Measurement Function
1010 !
1020 DEF FNFixt_comp(@Hp4294a,INTEGER Scode,Standard$)
1030 DIM Inp_char$(9),Err_mes$(50)
1040 INTEGER Err_no
1050 OUTPUT @Hp4294a;"*CLS"
1060 PRINT "Set "&Standard$&"-Connection"
1070 INPUT "OK? [Y/N]",Inp_char$
```

```
1080 IF UPC$(Inp_char$)="Y" THEN
1090   ON INTR Scode GOTO Meas_end
1100   ENABLE INTR Scode;2
1110   SELECT Standard$
1120     CASE "Open"
1130       OUTPUT @Hp4294a;"COMA"
1140     CASE "Short"
1150       OUTPUT @Hp4294a;"COMB"
1160     CASE "Load"
1170       OUTPUT @Hp4294a;"COMC"
1180   END SELECT
1190   PRINT "Now measuring..."
1200 Meas_wait: GOTO Meas_wait
1210 Meas_end: !
1220   PRINT Standard$&" Data Measurement Complete"
1230   RETURN 0
1240 ELSE
1250   PRINT "Program Interruption"
1260   RETURN -1
1270 END IF
1280 FNEND
1290 !
1300 ! Data Input Function
1310 !
1320 SUB Inp_data(Mes$,Inp_val)
1330   DIM Inp_char$(30)
1340   ON ERROR GOTO Inp_start
1350 Inp_start:!
1360   PRINT "Input "&Mes$
1370   INPUT "Value?",Inp_char$
1380   Inp_val=VAL(UPC$(Inp_char$))
1390   PRINT "Input value: ";Inp_val
1400   INPUT "OK? [Y/N]",Inp_char$
1410   IF UPC$(Inp_char$)<>"Y" THEN Inp_start
1420   OFF ERROR
1430 SUBEND
```

## Preparing For Accurate Measurement Fixture Compensation

Example 4-4 shows a sample program that takes in data for use in fixture compensation. This sample program is given the file name `com_inpu.bas` and is stored on the sample program disk.

This program reads open data, short data and load data from the files (`COM_DATA` and `STD_VAL`) retained by the program shown in Example 4-3 and sets them.

Lines 50 to 140	These lines distinguish between the external controller and Instrument BASIC and set the GPIB address and the select code. In the case of Instrument BASIC, flash memory is used as the storage unit.
Lines 150 to 180	These lines substitute the selection of data measurement points, the number of compensation data measurement points (100 for fixed measurement points), the name of the file for reading compensation data, and the name of the file for reading standard value to the variables <code>Cal_point\$</code> , <code>Point</code> , <code>File\$</code> and <code>Std_file\$</code> , respectively.
Lines 220 to 250	These lines reset the Agilent 4294A and then assign the data measurement points to <code>Cal_point\$</code> .
Lines 290 to 310	These lines read open data, short data and load data from the file named <code>File\$</code> in the sequence shown in Example 4-3 to store them in the arrays <code>Com_o(*)</code> , <code>Com_s(*)</code> , and <code>Com_l(*)</code> , respectively.
Lines 330 to 350	These lines read open/short/load standard values from the file named <code>Std_file\$</code> in sequence as written in Example 4-3 and store them in the variables <code>Open_g</code> , <code>Open_c</code> , <code>Short_r</code> , <code>Short_l</code> , <code>Load_r</code> , and <code>Load_l</code> respectively.
Lines 390 to 440	These lines set the standard values. The open standard capacitance needs to be in femtofarad, so these lines make the necessary conversion.
Line 480	This line selects the IEEE 64-bit floating-point format for the data transfer format.
Line 490	This line calculates data size from the program variable <code>Point</code> and creates a header to be used at the time of data transfer.
Lines 510 to 580	These lines enter data for open/short/load compensation. When the data are entered, the open/short/load compensation of the fixture compensation functions is turned on.

### Example 4-4

#### Data entry for fixture compensation

```
10 DIM Header$(9),Cal_point$(9),File$(20),Std_file$(20)
20 DIM Com_o(1:100,1:2),Com_s(1:100,1:2),Com_l(1:100,1:2)
30 REAL Open_g,Open_c,Short_r,Short_l,Load_r,Load_l
40 INTEGER Scode,Point
50 IF SYSTEM$("SYSTEM ID")="HP4294A" THEN
60   ASSIGN @Hp4294a TO 800
70   ASSIGN @Binary TO 800;FORMAT OFF
80   MASS STORAGE IS ":INTERNAL1,5"
90   Scode=8
100 ELSE
110   ASSIGN @Hp4294a TO 717
120   ASSIGN @Binary TO 717;FORMAT OFF
130   Scode=7
140 END IF
```



```
150 Cal_point$="FIXED"
160 Point=100
170 File$="COM_DATA"
180 Std_file$="STD_VAL"
190 !
200 ! Initial Setting
210 !
220 OUTPUT @Hp4294a;"PRES"
230 OUTPUT @Hp4294a;"*OPC?"
240 ENTER @Hp4294a;Buff$
250 OUTPUT @Hp4294a;"CALP ";Cal_point$
260 !
270 ! Load Data
280 !
290 ASSIGN @File TO File$
300 ENTER @File;Com_o(*),Com_s(*),Com_l(*)
310 ASSIGN @File TO *
320 !
330 ASSIGN @File TO Std_file$
340 ENTER @File;Open_g,Open_c,Short_r,Short_l,Load_r,Load_l
350 ASSIGN @File TO *
360 !
370 ! Define Standard Value
380 !
390 OUTPUT @Hp4294a;"DCOMOPENG ";Open_g
400 OUTPUT @Hp4294a;"DCOMOPENC ";Open_c/1.E-15
410 OUTPUT @Hp4294a;"DCOMSHORR ";Short_r
420 OUTPUT @Hp4294a;"DCOMSHORL ";Short_l
430 OUTPUT @Hp4294a;"DCOMLOADR ";Load_r
440 OUTPUT @Hp4294a;"DCOMLOADL ";Load_l
450 !
460 ! Input Compensation Data
470 !
480 OUTPUT @Hp4294a;"FORM3"
490 Header$="#6"&IVAL$(Point*2*8,10)
500 !
510 OUTPUT @Hp4294a;"INPUCOMC1 "&Header$;
520 OUTPUT @Binary;Com_o(*),END
530 !
540 OUTPUT @Hp4294a;"INPUCOMC2 "&Header$;
550 OUTPUT @Binary;Com_s(*),END
560 !
570 OUTPUT @Hp4294a;"INPUCOMC3 "&Header$;
580 OUTPUT @Binary;Com_l(*),END
590 !
600 END
```

## **Port Extension Compensation**

With either 7 mm or PROBE selected as the adapter, you can compensate the delay time due to port extension by using the port extension compensation functions when connecting an extension cable to the adapter.

- “PORE” on page 390

With the port extension compensation functions turned on, you can set the extent of compensation in terms of the value resulting from converting either delay time or an electrical length formulated as delay time  $\times$  ray velocity. To set the extent of compensation, use the commands given below.

- “PORTZ” on page 391
- “PORTL” on page 391

---

## **5 Starting a Measurement (Trigger) and Detecting the Completion of a Measurement (End of Sweeps)**

This chapter describes how to generate a trigger to start a measurement and how to detect the completion of a measurement.

## Triggering a Measurement (Starting a Measurement)

### Trigger system

The trigger system of the Agilent 4294A has three states: “Idle,” “Waiting for Trigger,” and “Measurement” as shown in Figure 5-1.

Figure 5-1

Trigger system

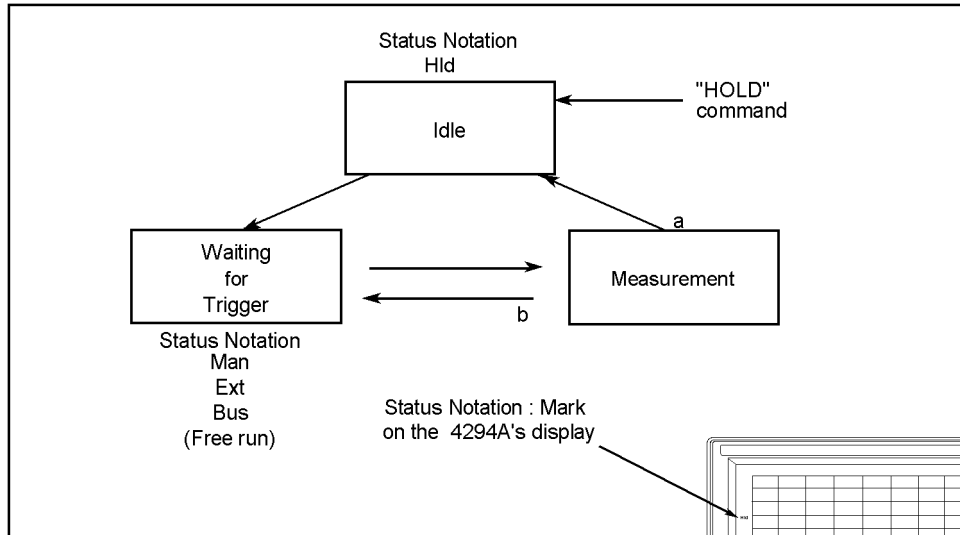

4294ape016

The state transitions in the trigger system are described below.

Executing the following command causes a transition to the “Idle” state.

- “HOLD” on page 307

Setting the number of sweeps with the following commands causes a transition to the “Waiting for Trigger” state.

Command	Number of measurements
“SING” on page 424	Once
“NUMG” on page 353	Specified number of times
“CONT” on page 274	Continuous (until “HOLD”, “SING”, or “NUMG” is executed)

Generating a trigger in the “Waiting for Trigger” state causes a transition to the “Measurement” state and initiates a measurement (one or more sweeps). The method used to generate a trigger varies with the trigger source setting. To set the trigger source, use the following command.

- “TRGS” on page 446

**Triggering a Measurement (Starting a Measurement)**

Trigger source setting	Method of generating a trigger
Internal trigger (INT)	Automatically generates an internal trigger.
External trigger (EXT)	Enters a trigger signal from the EXT TRIGGER terminal on the rear panel to generate a trigger.
GPIB/LAN trigger (BUS)	Executes the “*TRG” command on page 253 or the HP BASIC TRIGGER command to generate a trigger.
Manual trigger (MAN)	Uses the following key sequence on the front panel to generate a trigger: <b>[Trigger] - SOURCE[ ] - MANUAL</b>

The state transition after the completion of each sweep varies depending on the sweep count setting.

- Once Transitions to the “Idle” state (a in Figure 5-1).
- Specified number of times Repeats a transition to the “Waiting for Trigger” state until the specified number of sweeps are completed (b in Figure 5-1). After the completion of the specified number of sweeps, there is a transition to the “Idle” state (a in Figure 5-1).
- Continuous Repeats a transition to the trigger wait state (b in Figure 5-1).

**Triggering a measurement**

**To make measurements continuously (to automatically generate triggers continuously)**

- Step 1.** Use the “TRGS” command to set the trigger source to the internal trigger.
- Step 2.** Use the “CONT” command to set the sweep setting to continuous sweep.

**To make a measurement at any desired time (to generate a trigger from an external controller)**

- Step 1.** Use the “TRGS” command to set the trigger source to the internal trigger.
- Step 2.** Use the “SING” or “NUMG” command to execute a single sweep or the specified number of sweeps at any desired time.

Or

- Step 1.** Use the “TRGS” command to set the trigger source to the GPIB/LAN trigger.
- Step 2.** Use the “CONT” command to set the sweep setting to continuous sweep.
- Step 3.** Execute the “\*TRG” command on page 253 or the HP BASIC TRIGGER command (execute the group execution trigger) at any desired time.

**NOTE**

You can use the group execution trigger (GET) when you want to simultaneously trigger all devices connected to the controller that can be triggered.

## Waiting for the Completion of One or More Sweeps (Detecting the Completion of a Measurement)

### Using the status register

You can detect the state of the Agilent 4294A through its status register. The completion of one or more sweeps is indicated by the instrument event status register. To detect the completion of one or more sweeps from a program using the information in this register, use an SRQ (service request).

To detect the completion of one or more sweeps with an SRQ, use the commands below.

- “\*SRE” on page 252
- “ESNB” on page 304

The procedure is as follows:

- Step 1.** Make the setting so that the Agilent 4294A generates an SRQ when the sweep completion bit in the instrument event status register is set to “1.”
- Step 2.** Generate a trigger to start one or more sweeps.
- Step 3.** Perform the interrupt processing in the program when an SRQ is generated.

Figure 5-2

SRQ generation sequence (at the end of one or more sweeps)

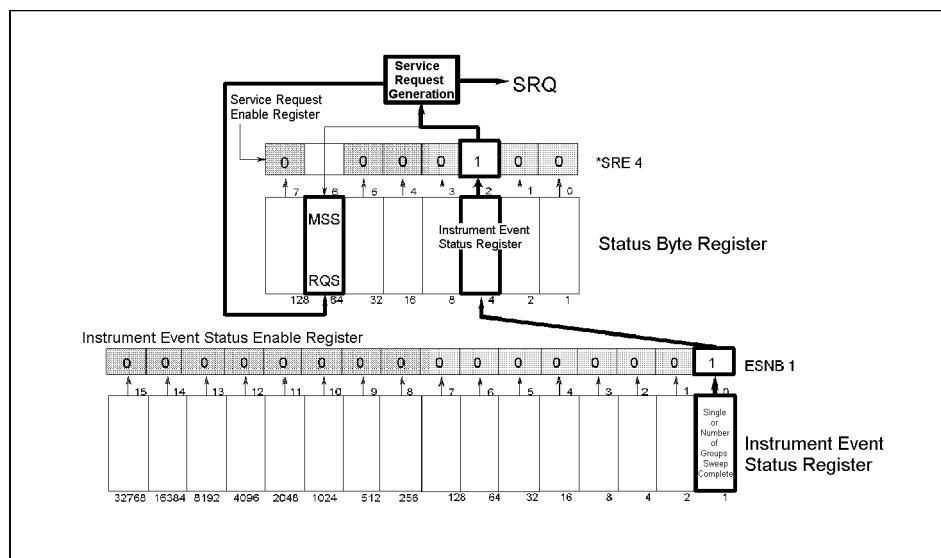

Example 5-1 is a sample program using an SRQ to detect the completion of sweeps. This program is stored on the sample program disk with the swp\_srq.bas filename.

This program sets the sweep averaging factor to 4, makes the SRQ setting, and then performs four sweeps. When an SRQ is generated at the completion of the sweeps, the program displays the completion message and then finishes.

## Starting a Measurement (Trigger) and Detecting the Completion of a Measurement (End of Sweeps)

### Waiting for the Completion of One or More Sweeps (Detecting the Completion of a Measurement)

Lines 30 to 90	Identifies the external controller and Instrument BASIC and sets the GPIB address and the select code.
Lines 110 to 130	Sets the trigger source to the internal trigger and sets the sweep averaging factor to 4.
Lines 150 to 160	Enables Bit 0 (sweep completion bit) in the instrument event status register and sets Bit 2 in the service request enable register to 1.

---

**NOTE**

In addition to the sweep completion bit, another bit is provided separately to indicate the completion of data measurements for adapter setting, user calibration, and fixture compensation. To detect the completion of these measurements, enable Bit 8 in the instrument event status register.

---

Lines 170 to 190	Clears the status byte register and the instrument event status register.
Lines 210 to 220	Sets the branch destination for the SRQ interrupt and enables the SRQ interrupt can be used.
Line 230	Executes the command to perform four sweeps.
Line 250	Waits for the completion of the sweeps.
Line 260	Displays the sweep completion message.

**Example 5-1****Detecting the completion of sweeps using an SRQ**

```
10 DIM Buff$(9)
20 INTEGER Scode
30 IF SYSTEM$("SYSTEM ID")="HP4294A" THEN
40   ASSIGN @Hp4294a TO 800
50   Scode=8
60 ELSE
70   ASSIGN @Hp4294a TO 717
80   Scode=7
90 END IF
100 !
110 OUTPUT @Hp4294a;"TRGS INT"
120 OUTPUT @Hp4294a;"AVERFACT 4"
130 OUTPUT @Hp4294a;"AVER ON"
140 !
150 OUTPUT @Hp4294a;"ESNB 1"
160 OUTPUT @Hp4294a;"*SRE 4"
170 OUTPUT @Hp4294a;"*CLS"
180 OUTPUT @Hp4294a;"*OPC?"
190 ENTER @Hp4294a;Buff$
200 !
210 ON INTR Scode GOTO Swp_end
220 ENABLE INTR Scode;2
230 OUTPUT @Hp4294a;"NUMG 4"
240 PRINT "Waiting..."
250 Swp_wait: GOTO Swp_wait
260 Swp_end: PRINT "Sweep Complete"
270 END
```

## Starting a Measurement (Trigger) and Detecting the Completion of a Measurement (End of Sweeps)

### Waiting for the Completion of One or More Sweeps (Detecting the Completion of a Measurement)

#### Using the \*OPC? command

The “SING” command on page 424 and “NUMG” command on page 353 are overlap commands whose executions are finished at the completion of one or more sweeps. Therefore, if you start one or more sweeps with these commands, you can detect their completion with the following command.

- “\*OPC?” on page 251

Example 5-2 shows a sample program to detect the completion of a sweep by using the “\*OPC?” command. This program is stored on the sample program disk with the swp\_opc.bas filename.

This program starts a sweep from the “SING” command, waits for the completion of this command’s execution with the “\*OPC?” command (the completion of a single sweep), displays a message at the completion of the sweep, and then finishes.

Lines 20 to 60	Identifies the external controller and Instrument BASIC and sets the GPIB address.
Line 80	Sets the trigger source to the internal trigger.
Lines 90	Starts a single sweep.
Lines 110 to 120	Executes the “*OPC?” command and waits for 1 to be returned (the completion of the sweep).
Line 130	Displays the sweep completion message.

#### Example 5-2

#### Detecting the completion of a sweep using the “\*OPC?” command

```
10   DIM Buff$(9)
20   IF SYSTEM$("SYSTEM ID")="HP4294A" THEN
30     ASSIGN @Hp4294a TO 800
40   ELSE
50     ASSIGN @Hp4294a TO 717
60   END IF
70   !
80   OUTPUT @Hp4294a;"TRGS INT"
90   OUTPUT @Hp4294a;"SING"
100  PRINT "Waiting..."
110  OUTPUT @Hp4294a;"*OPC?"
120  ENTER @Hp4294a;Buff$
130  PRINT "Sweep Complete"
140  END
```

#### Inserting a wait

You can use a setting to make the controller wait for the completion of one or more sweeps performed by the Agilent 4294A (for example, using the WAIT command of HP BASIC). This method is simple, but if you set an inappropriate wait, unexpected errors could occur.



---

## **6 Reading/Writing Measurement Data**

This chapter describes how to read and write measurement data and how to obtain level monitoring and limit test results.

## Data Transfer Format

The format applicable when you read measurement parameter settings from the Agilent 4294A (as when you read the sweep start point with “STAR?”) is the ASCII format, regardless of which data transfer format has been specified.

You can select either the ASCII format (default) or one of the binary formats for reading measurement data, waveform analysis results and so on from the Agilent 4294A (as when you read a data trace array with “OUTPDTRC?”). As for binary formats, you can select the IEEE 32-bit floating point format, IEEE 64-bit floating point format, or MS-DOS personal computer format as the appropriate format for your controller. Use the following commands for selecting a desired data transfer format:

Data Transfer Format	Command
IEEE 32-bit floating point format	“FORM2” on page 306
IEEE 64-bit floating point format	“FORM3” on page 306
ASCII format (Default)	“FORM4” on page 306
MS-DOS personal computer format	“FORM5” on page 306

### ASCII format (Form 4)

When you select the ASCII format as the data transfer format, numbers are transferred as ASCII bytes, each of which corresponds to one of the formats shown below. Note that numbers are separated from one another with a comma (“,”) in accordance with the IEEE 488.2 specification.

#### NOTE

Each numeric data character string is different in length from the others. Before extracting each piece of data from character strings, therefore, you must remember that commas do not always appear in the same locations.

- Integer Format

Figure 6-1 shows this format. Numbers are expressed as integers. For example, 201 is expressed as “+201” or “201.”

Figure 6-1

#### Integer Format

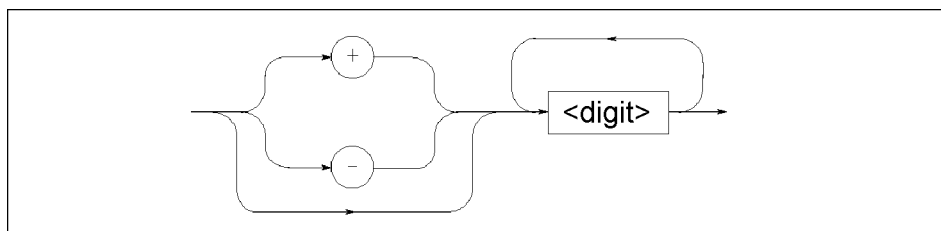

- Floating Point Format

Figure 6-2 shows this format. Numbers are expressed with floating points. For example, 1000 is expressed as “1.0E3.”

Figure 6-2

**Floating Point Format**

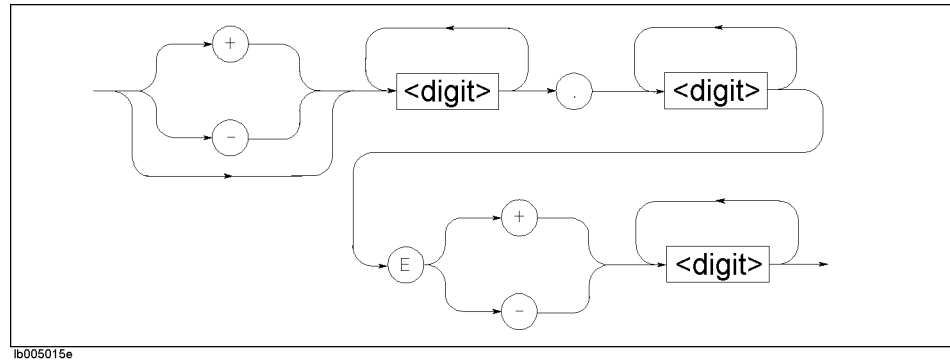

**IEEE 32-bit floating point format (Form 2)**

In this format, each number is expressed by four bytes. Therefore, data containing 201 measured values is 1,608 bytes long (two pieces of data per measurement point). Numbers are transferred in the format shown in Figure 6-3.

Figure 6-3

**IEEE 32-bit Floating Point Data Transfer Format**

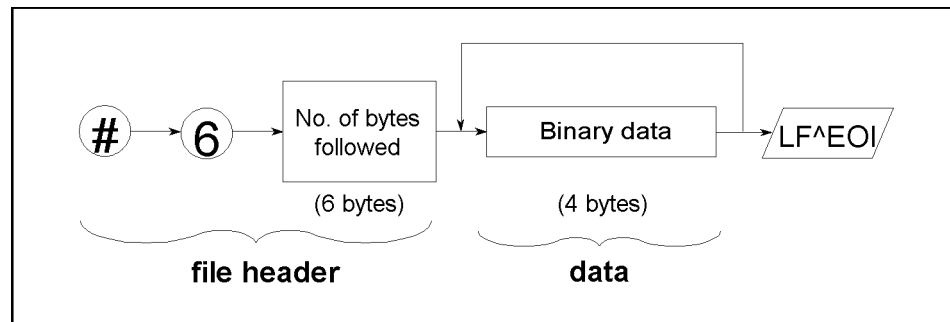

4294ape014

### IEEE 64-bit floating point format (Form 3)

With this format, each number is expressed with eight bytes. Therefore, data containing 201 measured values is 3,216 bytes long (2 pieces of data per measurement point). Numbers are transferred in the format shown in Figure 6-4.

Figure 6-4

#### IEEE 64-bit Floating Point Data Transfer Format

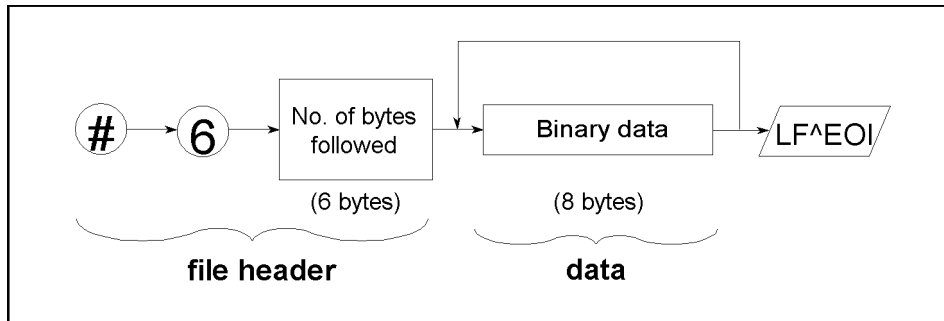

4294ape015

### MS-DOS personal computer format (Form 5)

This format is identical to the IEEE 32-bit floating point format except that data bytes are arranged in the reverse order. You do not need to reformat your data as you manipulate it on a personal computer in the DOS environment.

## Internal Data Processing

### Data processing sequence

Figure 6-5 outlines the sequence of data processing performed within the Agilent 4294A.

**Figure 6-5** Agilent 4294A Data Processing Sequence

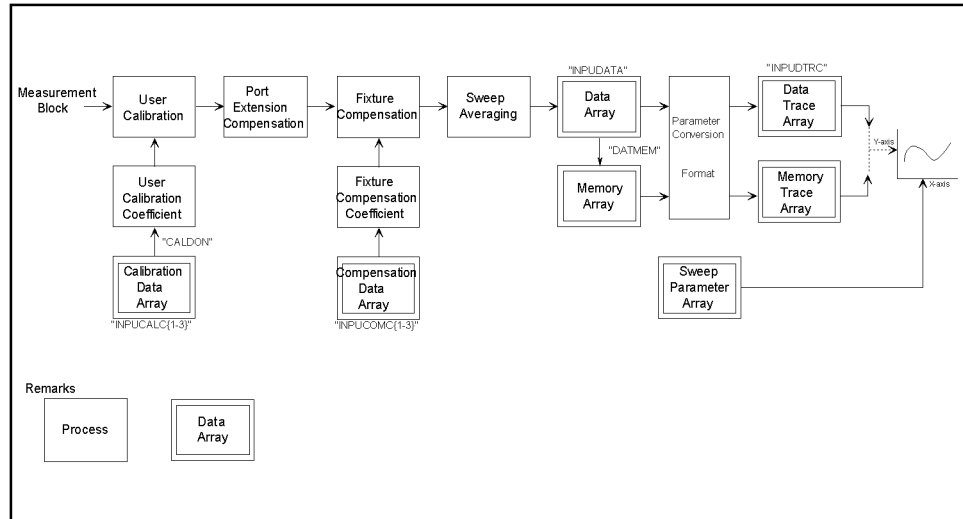

4294ape020

The following describe each of the data arrays shown in Figure 6-5.

### Internal data arrays

#### Data array

The data array contains the results of user calibration, port extension compensation, sweep averaging and fixture compensation performed on the measured data. Each result is stored as a complex number (R-X). Use the following commands to read or write the data array.

- “OUTPDATA?” on page 364
- “OUTPDATAP?” on page 364
- “INPU DATA” on page 310

#### Memory array

The memory array contains a copy of the data array available when the “DATMEM” command on page 277 is executed. Use the following commands to read the memory array. Note that you cannot write any part of the memory array.

- “OUTPMEMO?” on page 374
- “OUTPMEMOP?” on page 374

### Data trace array

The data trace array contains data that appears on the screen as data trace, that is, the result of measurement parameter conversion and arithmetic performed on the data array. Each result is stored as a complex number, regardless of whether the data is a scalar or vector. Therefore, if the data is a scalar, “0” is stored in the imaginary number part. Use the following commands to read or write the data trace array.

- “OUTPDTRC?” on page 367
- “OUTPDTRCP?” on page 368
- “INPUDTRC” on page 311

### Memory trace array

The memory trace array contains data that appears on the screen as memory trace, that is, the result of parameter conversion performed on the memory array. Use the following commands to read the memory trace array. Note that you cannot write any part of the memory trace array.

- “OUTPMTRC?” on page 377
- “OUTPMTRCP?” on page 378

### Calibration data array

The calibration data array contains open, short and load measurement data used for calculation of the user calibration coefficient. These data are stored as complex numbers. Three different types of arrays are available to choose from depending on the type of measurement data (open, short, or load data).

Array Number <sup>*1</sup>	Stored Data
1	Open measurement data (G-B) for user calibration coefficient calculation
2	Short measurement data (R-X) for user calibration coefficient calculation
3	Load measurement data (R-X) for user calibration coefficient calculation

\*1.This number corresponds to the number provided at the end of the command.

Use the following commands to read or write the calibration data array.

- “OUTPCALC{1-3}?” on page 362
- “INPUCALC{1-3}” on page 309

The calibration coefficient is calculated and stored in volatile memory (RAM) when all arrays are written.

### Compensation data array

The compensation data array contains open, short and load measurement data used for calculation of the fixture compensation coefficient. These data are stored as complex numbers. Three different types of arrays are available to choose from depending on the type of measurement data (open, short, or load data).

Array Number *1	Stored Data
1	Open measurement data (G-B) for fixture compensation coefficient calculation
2	Short measurement data (R-X) for fixture compensation coefficient calculation
3	Load measurement data (R-X) for fixture compensation coefficient calculation

\*1. This number corresponds to the number provided at the end of the command.

Use the following commands to read or write the compensation data array.

- “OUTPCOMC{1-3}?” on page 363
- “INPUCOMC{1-3}” on page 310

### Sweep parameter array

The sweep parameter array contains sweep parameters for all measurement points. Use the following commands to read the sweep parameter array. Note that you cannot write any part of the sweep parameter array.

- “OUTPSWPRM?” on page 383
- “OUTPSWPRMP?” on page 383

### Saving array as file

You can save an internal data array as a file. This feature saves time and effort because you can recall the file later and avoid the need to again perform the arithmetic. Use the following commands to save or recall an internal data array. See Chapter 8 , “Saving/Recalling a Measurement Result/Measurement Setup,” for more information.

- “SAVCAL” on page 403
- “SAVDAT” on page 404
- “SAVDTRC” on page 407
- “SAVMEM” on page 407
- “SAVMTRC” on page 408
- “SAVDASC” on page 403
- “SAVDDAT” on page 404
- “RECD” on page 395

---

#### NOTE

You can save an internal data array in the touchstone format by “SAVDS1P” on page 405. But you cannot recall the file.

## Reading/Writing Data

### Reading/writing measurement data

#### Reading/writing array in ASCII format

Example 6-1 shows the process of reading and writing array data in the ASCII format. This program is available under the filename of “data\_b2a.bas” on the sample program disk.

This program reads the data trace array for trace B in ASCII format and writes it to the data trace array for trace A.

Lines 30 to 70	Identifies the external controller and Instrument BASIC and sets the GPIB address.
Line 90	Substitutes the number of measurement points into the “Nop” variable.
Lines 110 to 120	Specifies ASCII format as data transfer format and sets the number of measurement points to Nop.
Lines 140 to 150	Holds the trigger and displays traces A and B on separate screens.
Lines 160 to 190	Specifies trace B as active trace, performs auto scaling, and reads the display format to assign it the “Fmt\$” variable.
Lines 210 to 220	Reads the data trace array for trace B and stores it in Trc(*).
Lines 240 to 250	Specifies trace A as active trace and sets the display format to “Fmt\$.”
Line 260	Writes “Trc(*)” to the data trace array for trace A.
Line 270	Performs auto-scaling.

#### Example 6-1

#### Reading/Writing Data Trace Array in the ASCII Format

```
10 DIM Trc(1:201,1:2),Fmt$[9]
20 INTEGER Nop
30 IF SYSTEM$("SYSTEM ID")="HP4294A" THEN
40 ASSIGN @Hp4294a TO 800
50 ELSE
60 ASSIGN @Hp4294a TO 717
70 END IF
80 !
90 Nop=201
100 !
110 OUTPUT @Hp4294a;"FORM4"
120 OUTPUT @Hp4294a;"POIN ";Nop
130 !
140 OUTPUT @Hp4294a;"HOLD"
150 OUTPUT @Hp4294a;"SPLD ON"
160 OUTPUT @Hp4294a;"TRAC B"
170 OUTPUT @Hp4294a;"AUTO"
180 OUTPUT @Hp4294a;"FMT?"
190 ENTER @Hp4294a;Fmt$
200 !
210 OUTPUT @Hp4294a;"OUTPDTRC?"
220 ENTER @Hp4294a;Trc(*)
230 !
```



```

240   OUTPUT @Hp4294a;"TRAC A"
250   OUTPUT @Hp4294a;"FMT "&Fmt$
260   OUTPUT @Hp4294a;"INPUOTRC ";Trc(*)
270   OUTPUT @Hp4294a;"AUTO"
280   !
290   END
  
```

### Reading/writing data array in a binary format

Example 6-2 shows the process of reading and writing array in binary format. This program is available under the filename of “mem2dat.bas” on the sample program disk.

This program reads the memory trace array for trace A in the IEEE 64-bit floating point format and writes it to the data trace array.

- Lines 30 to 90      Identifies the external controller and Instrument BASIC and sets the GPIB address.
- Lines 110 to 120    Substitutes the trace selected as the active trace and the number of measurement points into the corresponding variables Act\_trc\$ and Nop, respectively.
- Lines 140 to 150    Specifies the IEEE 64-bit floating point format as data transfer format and sets the number of measurement points to Nop.
- Lines 170 to 180    Holds the trigger and sets the active trace to Act\_trc\$.
- Lines 190 to 200    Clears error queue and specifies memory trace as the trace to be displayed.
- Lines 210 to 220    Checks for errors.
- Line 240            An error message appears if error No. 34 occurs (error indicating that an attempt was made to use memory trace when no data has been stored as memory trace). In the event of this error, program execution stops without performing any operation.
- Lines 260 to 270    Executes a memory trace array read command, reads the header, and substitutes it into the “Header\$” variable.
- Line 280            Reads the memory trace array and stores it in “Trc(\*)” (array variable). Binary data must be read without being formatted; therefore, an I/O path (@Binary) that has been set to read without being formatted is used.
- Line 290            Reads the terminator (LF^EOI) provided at the end of the data.
- Line 310            Specifies data trace as the trace to be displayed.
- Lines 320 to 330    Writes “Trc(\*)” to the data trace array by first sending a data trace array write command with “Header\$” (header part). Next, “Trc(\*)” (data part) is sent. When the data part is sent, an I/O path (@Binary) that has been set to send without being formatted is used.

**Example 6-2**

**Reading/Writing Data Trace Array in a Binary Format**

```
10   DIM Trc(1:201,1:2),Act_trc$(9),Err_mes$(50),Header$(9),Buff$(9)
20   INTEGER Err_no,Nop
30   IF SYSTEM$("SYSTEM ID")="HP4294A" THEN
40     ASSIGN @Hp4294a TO 800
50     ASSIGN @Binary TO 800;FORMAT OFF
60   ELSE
70     ASSIGN @Hp4294a TO 717
80     ASSIGN @Binary TO 717;FORMAT OFF
90   END IF
100  !
110  Act_trc$="A"
120  Nop=201
130  !
140  OUTPUT @Hp4294a;"FORM3"
150  OUTPUT @Hp4294a;"POIN ";Nop
160  !
170  OUTPUT @Hp4294a;"HOLD"
180  OUTPUT @Hp4294a;"TRAC "&Act_trc$
190  OUTPUT @Hp4294a;"*CLS"
200  OUTPUT @Hp4294a;"DISP MEMO"
210  OUTPUT @Hp4294a;"OUTPERRO?"
220  ENTER @Hp4294a;Err_no,Err_mes$
230  IF Err_no=34 THEN
240    PRINT Err_mes$
250  ELSE
260    OUTPUT @Hp4294a;"OUTPMTRC?"
270    ENTER @Hp4294a USING "#,8A";Header$
280    ENTER @Binary;Trc(*)
290    ENTER @Hp4294a USING "#,1A";Buff$
300    !
310    OUTPUT @Hp4294a;"DISP DATA"
320    OUTPUT @Hp4294a;"INPUDTRC "&Header$;
330    OUTPUT @Binary;Trc(*),END
340  END IF
350  !
360  END
```

## Reading level monitoring results

To read monitoring results of oscillator (OSC) power and dc bias levels, you need to use the following commands to turn ON the level monitor function before starting measurements:

- “OMON” on page 354
- “BMON” on page 264

Use the following commands to read the level monitoring results:

- “OUTPVAC?” on page 383
- “OUTPVACP?” on page 384
- “OUTPIAC?” on page 369
- “OUTPIACP?” on page 370
- “OUTPDC?” on page 365
- “OUTPDCP?” on page 365

Example 6-3 shows a sample program to read the level monitoring results. This program is available under the filename of “lvl\_mon.bas” on the sample program disk.

This program specifies the oscillator power and dc bias levels, turns ON the level monitor function, performs a sweep once, and reads and displays the level monitoring results.

Lines 50 to 110	Identifies the external controller and Instrument BASIC and sets the GPIB address.
Lines 130 to 170	Substitutes the selected signal source output mode, the signal source output level, the dc bias level, the dc bias range, and the selected dc bias monitor function into the corresponding variables Osc_mode\$, Osc_pow, Dc_bias, Dc_b_rng\$, and Mon_bias\$, respectively.
Lines 190 to 220	Resets the Agilent 4294A and then sets the sweep start point, the sweep stop point, and the number of measurement points to 10 MHz, 20 MHz, and 11, respectively.
Lines 230 to 270	Sets the signal source output mode, the signal source output level, the dc bias level, and the dc bias range to Osc_mode\$, Osc_pow, Dc_bias and Dc_b_rng\$, respectively.
Lines 280 to 300	Turns ON the dc bias output and the signal source output level monitor function and sets the selected dc bias monitor function to Mon_bias\$.
Lines 320 to 340	Performs sweep once and waits for the sweep to be completed.
Line 360	Specifies the IEEE 64-bit floating point format as data transfer format.
Lines 380 to 410	Reads the signal source voltage level found by monitoring and stores it in “Mon_osc_v(*)”.
Lines 430 to 460	Reads the signal source current level found by monitoring and stores it in “Mon_osc_i(*)”.
Lines 480 to 510	Reads the DC bias level found by monitoring and stores it in “Mon_bias(*)”.
Lines 530 to 560	Reads the sweep parameter array and stores it in “Swp_prm(*)”.

## Reading/Writing Measurement Data

### Reading/Writing Data

Lines 580 to 630 Displays the contents of “Swp\_prm(\*)”, “Mon\_osc\_v(\*)”, “Mon\_osc\_i(\*)”, and “Mon\_bias(\*)”.

#### Example 6-3

#### Reading Level Monitoring Results

```
10 DIM Mon_osc_v(1:11),Mon_osc_i(1:11),Mon_bias(1:11),Swp_prm(1:11)
20 DIM Osc_mode$(9),Mon_bias$(9),Header$(9),Buff$(9),Img$(30)
30 REAL Osc_pow,Dc_bias
40 CLEAR SCREEN
50 IF SYSTEM$("SYSTEM ID")="HP4294A" THEN
60     ASSIGN @Hp4294a TO 800
70     ASSIGN @Binary TO 800;FORMAT OFF
80 ELSE
90     ASSIGN @Hp4294a TO 717
100    ASSIGN @Binary TO 717;FORMAT OFF
110 END IF
120 !
130 Osc_mode$="VOLT"
140 Osc_pow=1.0
150 Dc_bias=12.0
160 Dc_b_rng$="M10"
170 Mon_bias$="VOLT"
180 !
190 OUTPUT @Hp4294a;"PRES"
200 OUTPUT @Hp4294a;"STAR 10MHZ"
210 OUTPUT @Hp4294a;"STOP 20MHZ"
220 OUTPUT @Hp4294a;"POIN 11"
230 OUTPUT @Hp4294a;"POWMOD "&Osc_mode$
240 OUTPUT @Hp4294a;"POWE ";Osc_pow
250 OUTPUT @Hp4294a;"DCMOD VOLT"
260 OUTPUT @Hp4294a;"DCV ";Dc_bias
270 OUTPUT @Hp4294a;"DCRNG "&Dc_b_rng$
280 OUTPUT @Hp4294a;"DCO ON"
290 OUTPUT @Hp4294a;"OMON ON"
300 OUTPUT @Hp4294a;"BMON "&Mon_bias$
310 !
320 OUTPUT @Hp4294a;"SING"
330 OUTPUT @Hp4294a;"*OPC?"
340 ENTER @Hp4294a;Buff$
350 !
360 OUTPUT @Hp4294a;"FORM3"
370 !
380 OUTPUT @Hp4294a;"OUTPVAC?"
390 ENTER @Hp4294a USING "#,8A";Header$
400 ENTER @Binary;Mon_osc_v(*)
410 ENTER @Hp4294a USING "#,1A";Buff$
420 !
430 OUTPUT @Hp4294a;"OUTPIAC?"
440 ENTER @Hp4294a USING "#,8A";Header$
450 ENTER @Binary;Mon_osc_i(*)
460 ENTER @Hp4294a USING "#,1A";Buff$
470 !
480 OUTPUT @Hp4294a;"OUTPDC?"
490 ENTER @Hp4294a USING "#,8A";Header$
500 ENTER @Binary;Mon_bias(*)
510 ENTER @Hp4294a USING "#,1A";Buff$
520 !
530 OUTPUT @Hp4294a;"OUTPSWPRM?"
540 ENTER @Hp4294a USING "#,8A";Header$
550 ENTER @Binary;Swp_prm(*)
560 ENTER @Hp4294a USING "#,1A";Buff$
570 !
580 Img$="D.2DE,X,Z.4D,X,D.4DE,X,2D.3D"
```

```

590 PRINT "LEVEL MONITOR RESULT"
600 PRINT "Freq[Hz] OscV[V] OscI[A] DC V[V]"
610 FOR I=1 TO 11
620 PRINT USING Img$;Swp_prm(I),Mon_osc_v(I),Mon_osc_i(I),Mon_bias(
I)
630 NEXT I
640 END
    
```

## Reading limit test results

To read limit test results, use the following commands:

- “OUTPFAIP?” on page 369
- “OUTPLIML?” on page 372
- “OUTPLIMF?” on page 372
- “OUTPLIMM?” on page 373

Example 6-3 shows a sample program for reading limit test results. This program is available under the filename of “lim\_test.bas” on the sample program disk.

This program creates a limit line table, turns ON the limit test function, performs sweep once, and reads and displays those pieces of measurement data found to be unacceptable.

- |                  |   |
|------------------|---|
| Lines 100 to 140 | Identifies the external controller and Instrument BASIC and sets the GPIB address.  |
| Lines 150 to 220 | Substitutes the measurement parameter selection, the sweep start point, the sweep stop point, the number of measurement points, the maximum and minimum values of screen for trace A, and the maximum and minimum values of screen for trace B into the corresponding variables Meas_para\$, Star, Stop, Nop, Top_a, Btm_a, Top_b, and Btm_b, respectively. |
| Lines 240 to 410 | Substitutes the start point, the upper and lower limits for start point, the stop point, and the upper and lower limits for stop point for each of the limit line table segments into the corresponding variables Lim_star_a(*), U_lim_star_a(*), L_lim_star_a(*), Lim_stop_a(*), U_lim_stop_a(*), and L_lim_stop_a(*), respectively.                       |
| Lines 430 to 600 | Substitutes the parameters of the limit line table for trace B into the corresponding variables Lim_star_b(*), U_lim_star_b(*), L_lim_star_b(*), Lim_stop_b(*), U_lim_stop_b(*), and L_lim_stop_b(*) respectively.  |
| Lines 620 to 670 | Resets the Agilent 4294A and then sets the measurement parameters, the sweep start point, the sweep stop point, and the number of measurement points to the corresponding variables Meas_para\$, Star, Stop, and Nop and enables traces A and B to be displayed on separate screens.  |
| Lines 690 to 710 | Specifies trace A as the active trace and sets the maximum and minimum value of the screen for trace A to Top_a and Btm_a, respectively.  |
| Lines 720 to 850 | Creates a limit line table for trace A and turns ON the limit test function.  |

## Reading/Writing Measurement Data

### Reading/Writing Data

- Line 870 to 890 Specifies trace B as the active trace and sets the maximum and minimum value of the screen for trace B to Top\_b and Btm\_b, respectively.
- Lines 900 to 1030 Creates a limit line table for trace B and turns ON the limit test function.
- Lines 1050 to 1070 Performs a sweep once and waits for the sweep to be completed.
- Lines 1090 to 1110 Specifies trace A as the active trace and then reads the number of measurement points for trace A where the measurement data were found to be unacceptable.
- Lines 1130 to 1230 Specifies the ASCII format as the data transfer format and reads and displays the sweep parameter value, test result, and upper and lower limits for each of the measurement points for trace A where the measurement data were found to be unacceptable.
- Line 1250 Displays a message if the measurement data at all measurement points for trace A were found to be acceptable.
- Lines 1280 to 1300 Specifies trace B as the active trace and then reads the number of measurement points for trace B where the measurement data were found to be unacceptable.
- Lines 1320 to 1420 Specifies the ASCII format as data transfer format and reads and displays the sweep parameter value, test result, and upper and lower limits for each of the measurements points for trace B where the measurement data were found to be unacceptable.
- Line 1440 Displays a message if the measurement data at all measurement points for trace B were found to be acceptable.

**Example 6-4**

**Reading Limit Test Results**

```

10 REAL Star,Stop,Top_a,Btm_a,Top_b,Btm_b
20 REAL Fail_res_a(1:41,1:4),Fail_res_b(1:41,1:4)
30 REAL Lim_star_a(1:3),U_lim_star_a(1:3),L_lim_star_a(1:3)
40 REAL Lim_stop_a(1:3),U_lim_stop_a(1:3),L_lim_stop_a(1:3)
50 REAL Lim_star_b(1:3),U_lim_star_b(1:3),L_lim_star_b(1:3)
60 REAL Lim_stop_b(1:3),U_lim_stop_b(1:3),L_lim_stop_b(1:3)
70 DIM Meas_para$(9),Buff$(9)
80 INTEGER Nop,Fail_nop
90 CLEAR SCREEN
100 IF SYSTEM$("SYSTEM ID")="HP4294A" THEN
110 ASSIGN @Hp4294a TO 800
120 ELSE
130 ASSIGN @Hp4294a TO 717
140 END IF
150 Meas_para$="CSD"
160 Star=1.0E+7
170 Stop=5.0E+7
180 Nop=41
190 Top_a=2.0E-5
200 Btm_a=0.
210 Top_b=.02
220 Btm_b=0.
230 !
240 Lim_star_a(1)=1.0E+7
250 U_lim_star_a(1)=1.2E-5
260 L_lim_star_a(1)=8.E-6
270 Lim_stop_a(1)=2.0E+7
280 U_lim_stop_a(1)=1.2E-5
290 L_lim_stop_a(1)=8.E-6
300 Lim_star_a(2)=2.0E+7
310 U_lim_star_a(2)=1.2E-5
320 L_lim_star_a(2)=8.E-6
330 Lim_stop_a(2)=4.0E+7
340 U_lim_stop_a(2)=1.5E-5
350 L_lim_stop_a(2)=5.E-6
360 Lim_star_a(3)=4.0E+7
370 U_lim_star_a(3)=1.5E-5
380 L_lim_star_a(3)=5.E-6
390 Lim_stop_a(3)=5.0E+7
400 U_lim_stop_a(3)=1.5E-5
410 L_lim_stop_a(3)=5.E-6
420 !
430 Lim_star_b(1)=1.0E+7
440 U_lim_star_b(1)=.005
450 L_lim_star_b(1)=0.
460 Lim_stop_b(1)=2.0E+7
470 U_lim_stop_b(1)=.005
480 L_lim_stop_b(1)=0.
490 Lim_star_b(2)=2.0E+7
500 U_lim_star_b(2)=.005
510 L_lim_star_b(2)=0.
520 Lim_stop_b(2)=4.0E+7
530 U_lim_stop_b(2)=.01
540 L_lim_stop_b(2)=0.
550 Lim_star_b(3)=4.0E+7
560 U_lim_star_b(3)=.01
570 L_lim_star_b(3)=0.
580 Lim_stop_b(3)=5.0E+7
590 U_lim_stop_b(3)=.01
600 L_lim_stop_b(3)=0.
610 !

```

## Reading/Writing Measurement Data

### Reading/Writing Data

```
620 OUTPUT @Hp4294a;"PRES"
630 OUTPUT @Hp4294a;"MEAS "&Meas_para$
640 OUTPUT @Hp4294a;"STAR ";Star
650 OUTPUT @Hp4294a;"STOP ";Stop
660 OUTPUT @Hp4294a;"POIN ";Nop
670 OUTPUT @Hp4294a;"SPLD ON"
680 !
690 OUTPUT @Hp4294a;"TRAC A"
700 OUTPUT @Hp4294a;"TOPV ";Top_a
710 OUTPUT @Hp4294a;"BOTV ";Btm_a
720 OUTPUT @Hp4294a;"EDITLIML"
730 FOR I=1 TO 3
740 OUTPUT @Hp4294a;"LIMSADD"
750 OUTPUT @Hp4294a;"LIMSTAR ";Lim_star_a(I)
760 OUTPUT @Hp4294a;"LIMUSTAR ";U_lim_star_a(I)
770 OUTPUT @Hp4294a;"LIMLSTAR ";L_lim_star_a(I)
780 OUTPUT @Hp4294a;"LIMSTOP ";Lim_stop_a(I)
790 OUTPUT @Hp4294a;"LIMUSTOP ";U_lim_stop_a(I)
800 OUTPUT @Hp4294a;"LIMLSTOP ";L_lim_stop_a(I)
810 OUTPUT @Hp4294a;"LIMSTEST ON"
820 OUTPUT @Hp4294a;"LIMSDON"
830 NEXT I
840 OUTPUT @Hp4294a;"LIMEDONE"
850 OUTPUT @Hp4294a;"LIMITEST ON"
860 !
870 OUTPUT @Hp4294a;"TRAC B"
880 OUTPUT @Hp4294a;"TOPV ";Top_b
890 OUTPUT @Hp4294a;"BOTV ";Btm_b
900 OUTPUT @Hp4294a;"EDITLIML"
910 FOR I=1 TO 3
920 OUTPUT @Hp4294a;"LIMSADD"
930 OUTPUT @Hp4294a;"LIMSTAR ";Lim_star_b(I)
940 OUTPUT @Hp4294a;"LIMUSTAR ";U_lim_star_b(I)
950 OUTPUT @Hp4294a;"LIMLSTAR ";L_lim_star_b(I)
960 OUTPUT @Hp4294a;"LIMSTOP ";Lim_stop_b(I)
970 OUTPUT @Hp4294a;"LIMUSTOP ";U_lim_stop_b(I)
980 OUTPUT @Hp4294a;"LIMLSTOP ";L_lim_stop_b(I)
990 OUTPUT @Hp4294a;"LIMSTEST ON"
1000 OUTPUT @Hp4294a;"LIMSDON"
1010 NEXT I
1020 OUTPUT @Hp4294a;"LIMEDONE"
1030 OUTPUT @Hp4294a;"LIMITEST ON"
1040 !
1050 OUTPUT @Hp4294a;"SING"
1060 OUTPUT @Hp4294a;"*OPC?"
1070 ENTER @Hp4294a;Buff$
1080 !
1090 OUTPUT @Hp4294a;"TRAC A"
1100 OUTPUT @Hp4294a;"OUTPFAIP?"
1110 ENTER @Hp4294a;Fail_nop
1120 !
1130 IF Fail_nop>0 THEN
1140 OUTPUT @Hp4294a;"FORM4"
1150 OUTPUT @Hp4294a;"OUTPLIMF?"
1160 FOR I=1 TO Fail_nop
1170 ENTER @Hp4294a USING "#,K,K,K,K";Fail_res_a(I,1),Fail_res_a(I,
2),Fail_res_a(I,3),Fail_res_a(I,4)
1180 NEXT I
1190 PRINT "-- Trace A Failed Point --"
1200 PRINT "Frequency L_Limit U_Limit"
1210 FOR I=1 TO Fail_nop
1220 PRINT Fail_res_a(I,1),Fail_res_a(I,4),Fail_res_a(I,3)
1230 NEXT I
1240 ELSE
```



```
1250     PRINT "-- Trace A All Pass --"
1260   END IF
1270   !
1280   OUTPUT @Hp4294a;"TRAC B"
1290   OUTPUT @Hp4294a;"OUTPFAIP?"
1300   ENTER @Hp4294a;Fail_nop
1310   !
1320   IF Fail_nop>0 THEN
1330     OUTPUT @Hp4294a;"FORM4"
1340     OUTPUT @Hp4294a;"OUTPLIMF?"
1350     FOR I=1 TO Fail_nop
1360       ENTER @Hp4294a USING "#,K,K,K,K";Fail_res_b(I,1),Fail_res_b(I,
1370       2),Fail_res_b(I,3),Fail_res_b(I,4)
1370     NEXT I
1380     PRINT "-- Trace B Failed Point --"
1390     PRINT "Frequency  L_Limit  U_Limit"
1400     FOR I=1 TO Fail_nop
1410       PRINT Fail_res_b(I,1),Fail_res_b(I,4),Fail_res_b(I,3)
1420     NEXT I
1430   ELSE
1440     PRINT "-- Trace B All Pass --"
1450   END IF
1460   !
1470   END
```

### When to read/write data

If a read command is executed while a sweep is in progress, the data available when the command execution starts is read. To ensure the accuracy of the data you obtain, be sure to wait until the current sweep is complete before executing a read command. Considering the time it takes for your program to be executed to completion, an efficient approach is to synchronize the execution of a read command with the completion of the current sweep. To do this, use the status report structure and the “\*OPC?” command on page 251. See “Waiting for the Completion of One or More Sweeps (Detecting the Completion of a Measurement)” on page 74 for more information.

To write data properly, you need to execute a write command while no sweep is in progress. You can write data while a sweep is in progress. In this case, however, the data you write will be overwritten. You can suspend the sweep by executing the “HOLD” command on page 307.



---

# 7

## Processing Measurement Results

This chapter describes how to process measurement results using the marker function, the equivalent circuit analysis function, the trace bandwidth analysis function, and analysis commands.

## Reading Measurement Data at Specific Measurement Points (Using the Marker Function)

You can use the marker to read measurement data at specific points on the trace or search for the point that meets a specific condition such as the maximum value. You need to use the following command to turn ON the marker before using it.

- “MKR” on page 339

You can use the main marker (marker No. 0; hereafter referred to as the marker) when you execute the above command. To use one or more submarkers (markers No. 1–7), use the following command to turn them ON:

- “SMKR{1-7}” on page 425

You can also use the  $\Delta$  marker to obtain the result of subtraction of the  $\Delta$  marker-specified value from the marker- or submarker-specified value or the difference between these values. Use the following command to turn ON the  $\Delta$  marker:

- “DMKR” on page 292

When you turn ON a submarker or the  $\Delta$  marker, it appears where the marker is currently located.

### Moving the marker

#### Moving the marker to specific points

Use the following commands to move the marker, one of the submarkers, or the  $\Delta$  marker to a desired measurement point or sweep parameter value on the trace:

	Specific Measurement Point	Specific Sweep Parameter Value
Marker	“MKRP” on page 346	“MKRPRM” on page 347
Submarker	“SMKRP{1-7}” on page 426	“SMKRPRM{1-7}” on page 427
$\Delta$ Marker	“DMKRP” on page 294	“DMKRPRM” on page 295

#### Moving after search for positions that meet specific conditions

Use the following command to search for and move the marker to specific positions on the active trace such as maximum value, minimum value, peak, and measurement parameter value (target) specified with the “SEATARG” command (page 420):

- “SEAM” on page 414

When the active trace has two or more peaks or targets, the search is made as shown below after execution of the above command.

Peak                      Maximum peak (minimum peak if the peak has been defined as negative peak)

Target                     Target closest to the current marker position

You can use the following commands to sequentially search for the remaining peaks or targets.

## Reading Measurement Data at Specific Measurement Points (Using the Marker Function)

- “SEANPK” on page 414
- “SEANPKL” on page 414
- “SEANPKR” on page 415
- “SEAL” on page 413
- “SEAR” on page 415

With the marker’s search function, you can search for measurement points, expressed as peaks, that meet the definitions given in Figure 7-1. Use the following commands to define a peak.

- “PKDLTX” on page 388
- “PKDLTY” on page 389
- “PKPOL” on page 389

You can use the following command to set  $\Delta X$  and  $\Delta Y$  respectively to  $|X_L|$  and  $|Y_L|$  at the marker-specified measurement point.

- “MKRPKD” on page 346

Figure 7-1

### Defining Peak for Search by Marker

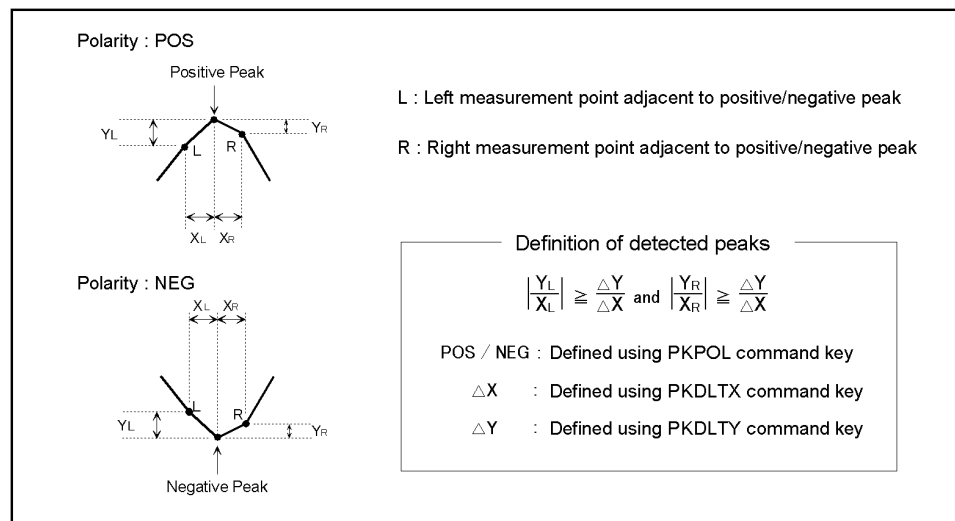

4294ape024

Search is made over the entire sweep range, unless otherwise specified. You can, however, use the following commands to limit the range to be searched:

- “PARS” on page 384
- “SEARMAX” on page 416
- “SEARMAXP” on page 417
- “SEARMIN” on page 418
- “SEARMINP” on page 419
- “MKRTR” on page 348
- “SEARNG” on page 419
- “SEGMNUM” on page 423

### Reading the marker-specified value

Use the following commands to read the marker-specified measurement or sweep parameter value.

	Measurement Parameter Value	Supplementary Reading for Measurement Parameter Value (Vector)	Sweep Parameter Value
Marker	"OUTPMKR?" on page 376		
	"MKRVAL?" on page 349	"MKRAUV?" on page 340	"MKRPRM" on page 347 Used for query
Submarker	"OUTPSMKR{1-7}?" on page 382		
	"SMKRVAL{1-7}?" on page 428	"SMKRAUV{1-7}?" on page 425	"SMKRPRM{1-7}" on page 427 Used for query
Δ Marker	"OUTPDMKR?" on page 366		
	"DMKRVAL" on page 296 Used for query* <sup>1</sup>	"DMKRAUV" on page 293 Used for query* <sup>1</sup>	"DMKRPRM" on page 295 Used for query

\*1. You can read parameter values only when you use the fixed Δ marker.

You can use the following command to display a list of all marker-specified values on the Agilent 4294A LCD. Note, however, that you cannot use these commands to read these values.

- "MKRL" on page 341

### Sample program for using the marker function

Example 7-1 shows a sample program for using the marker function. This program is available under the filename of "marker.bas" on the sample program disk.

This program performs sweep once, uses the marker function to search for the maximum peak and the minimum negative peak in the 10-100 MHz range, provides a submarker at each of these peaks, and reads and displays the submarker-specified values.

- Lines 30 to 70 Identifies the external controller and Instrument BASIC and sets the GPIB address.
- Lines 90 to 110 Substitutes the lower and upper border values for the search range and the trace selected as the active trace into the corresponding variables Sear\_min\$, Sear\_max\$, and Act\_trc\$, respectively.
- Lines 130 to 160 Resets the Agilent 4294A, performs a sweep once, and waits for the sweep to be completed.
- Lines 180 to 190 Sets the trace selected as the active trace to Act\_trc\$ and executes the auto scale to automatically set the scale parameters so that the waveforms fit on the screen.
- Lines 210 to 240 Turns ON the marker and sets the lower and upper border values for the search range to Sear\_min\$ and Sear\_max\$, respectively.
- Lines 260 to 300 Defines the peak by specifying "0.1/1e6" and "positive" as peak slope threshold and peak polarity, searches for the peak and moves the marker to that peak, and positions submarker 1 at the peak.
- Lines 320 to 340 Redefines the peak by specifying "negative" as peak polarity, searches

for the peak and moves the marker to that negative peak, and positions submarker 2 at the peak.

Lines 360 to 430 Reads and displays submarker-specified measurement parameter values.

**Example 7-1 Searching for Peaks Using the Marker**

```

10 DIM Sear_min$[9],Sear_max$[9],Act_trc$[9],Buff$[9]
20 REAL P_peak,N_peak
30 IF SYSTEM$("SYSTEM ID")="HP4294A" THEN
40 ASSIGN @Hp4294a TO 800
50 ELSE
60 ASSIGN @Hp4294a TO 717
70 END IF
80 !
90 Sear_min$="10MHZ"
100 Sear_max$="100MHZ"
110 Act_trc$="A"
120 !
130 OUTPUT @Hp4294a;"PRES"
140 OUTPUT @Hp4294a;"SING"
150 OUTPUT @Hp4294a;"*OPC?"
160 ENTER @Hp4294a;Buff$
170 !
180 OUTPUT @Hp4294a;"TRAC "&Act_trc$
190 OUTPUT @Hp4294a;"AUTO"
200 !
210 OUTPUT @Hp4294a;"MKR ON"
220 OUTPUT @Hp4294a;"PARS ON"
230 OUTPUT @Hp4294a;"SEARMIN "&Sear_min$
240 OUTPUT @Hp4294a;"SEARMAX "&Sear_max$
250 !
260 OUTPUT @Hp4294a;"PKDLTX 1MHZ"
270 OUTPUT @Hp4294a;"PKDLTY 0.1"
280 OUTPUT @Hp4294a;"PKPOL POS"
290 OUTPUT @Hp4294a;"SEAM PEAK"
300 OUTPUT @Hp4294a;"SMKR1 ON"
310 !
320 OUTPUT @Hp4294a;"PKPOL NEG"
330 OUTPUT @Hp4294a;"SEAM PEAK"
340 OUTPUT @Hp4294a;"SMKR2 ON"
350 !
360 OUTPUT @Hp4294a;"SMKRVAL1?"
370 ENTER @Hp4294a;P_peak
380 OUTPUT @Hp4294a;"SMKRVAL2?"
390 ENTER @Hp4294a;N_peak
400 !
410 PRINT "Search Range: "&Sear_min$&" - "&Sear_max$
420 PRINT "Positive Peak: ";P_peak;" [ohm]"
430 PRINT "Negative Peak: ";N_peak;" [ohm]"
440 END

```

## Analyzing Measurement Results

### Equivalent circuit analysis

With the Agilent 4294A, five different circuit models are available for equivalent circuit analysis as shown below depending on the type of measurement results obtained.

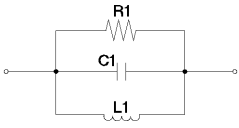
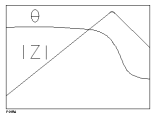
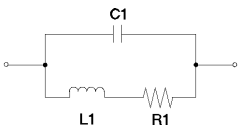
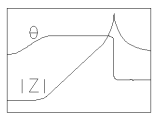
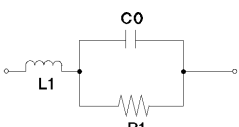
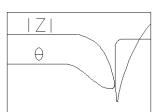
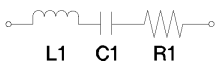
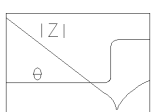
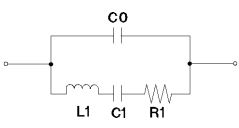
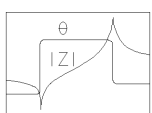
Equivalent Circuit Analysis Model	Sample Types	Typical Frequency Characteristics <sup>*1</sup>
A 	Inductor with Large Core Loss	
B 	Inductor and Resistor	
C 	Resistor with Large Resistance	
D 	Capacitor	
E 	Oscillator and Vibrator	

\*1.Measurement parameter:  $|Z|-\theta$ , Vertical display format: logged  $|Z|$  and linear  $\theta$

Use the following command to select the desired circuit model.

- “EQUC” on page 301

Use the following command to perform equivalent circuit analysis.

- “CALECPARA” on page 267

#### NOTE

The applicable range for equivalent circuit analysis is the same as the range searched by the marker.



When you execute the “CALECPARA” command, the analysis results will be automatically displayed. You can use the following command to select whether to display these results on the screen.

- “DISECPARA” on page 289

Use the following command for query to read equivalent circuit analysis results (equivalent circuit parameters: R1, C1, L1, C0).

- “DEFEC {R1|C1|L1|C0}” on page 286

You can use parameter values (R1, C1, L1, C0) obtained through equivalent circuit analysis to perform frequency characteristic simulation for such values and display the simulation results as memory trace. To do this, use the following command.

- “SIMFCHAR” on page 424

You can use the “DEFEC {R1|C1|L1|C0}” command (page 286) to specify the desired value of each of the parameters R1, C1, L1, and C0. Therefore, you can display frequency characteristics simulated based on desired parameter values.

Example 7-2 shows a sample equivalent circuit analysis program. This program is available under the filename “circuit.bas” on the sample program disk.

This program performs a sweep once, selects equivalent circuit model E, performs equivalent circuit analysis, and reads and displays the analysis results. This program also performs frequency characteristic simulation based on parameter values obtained through the analysis.

Lines 30 to 70	Identifies the external controller and Instrument BASIC and sets the GPIB address.
Lines 90 to 110	Substitutes the sweep center value, the sweep span value, and the selected equivalent circuit model into the corresponding variables Cent, Span, and model\$, respectively.
Lines 130 to 160	Resets the Agilent 4294A, sets impedance amplitude and phase as measurement parameters, and sets the sweep center value and the sweep span value to Cent and Span, respectively.
Lines 170 to 240	Performs a sweep once, performs auto scaling, and executes the auto scale to automatically set the scale parameters so that the waveforms fit on the screen.
Lines 250 to 260	Sets the selected equivalent circuit model to “Model\$” and performs equivalent circuit analysis.
Lines 270 to 400	Reads and displays equivalent circuit parameters R1, C1, L1, and C0.
Line 420	Performs frequency characteristic simulation.

### Example 7-2

#### Equivalent Circuit Analysis

```

10 DIM Model$(9),Buff$(9)
20 REAL Cent,Span,R1,C1,L1,C0
30 IF SYSTEM$("SYSTEM ID")="HP4294A" THEN
40     ASSIGN @Hp4294a TO 800
50 ELSE
60     ASSIGN @Hp4294a TO 717
70 END IF
80 !

```

## Processing Measurement Results

### Analyzing Measurement Results

```
90      Cent=6.0E+7
100     Span=2.0E+4
110     Model$="E"
120     !
130     OUTPUT @Hp4294a;"PRES"
140     OUTPUT @Hp4294a;"MEAS IMPH"
150     OUTPUT @Hp4294a;"CENT ";Cent
160     OUTPUT @Hp4294a;"SPAN ";Span
170     OUTPUT @Hp4294a;"SING"
180     OUTPUT @Hp4294a;"*OPC?"
190     ENTER @Hp4294a;Buff$
200     !
210     OUTPUT @Hp4294a;"TRAC A"
220     OUTPUT @Hp4294a;"AUTO"
230     OUTPUT @Hp4294a;"TRAC B"
240     OUTPUT @Hp4294a;"AUTO"
250     OUTPUT @Hp4294a;"EQUC CIR"&Model$
260     OUTPUT @Hp4294a;"CALECPARA"
270     OUTPUT @Hp4294a;"DEFECR1?"
280     ENTER @Hp4294a;R1
290     OUTPUT @Hp4294a;"DEFECC1?"
300     ENTER @Hp4294a;C1
310     OUTPUT @Hp4294a;"DEFECL1?"
320     ENTER @Hp4294a;L1
330     OUTPUT @Hp4294a;"DEFECC0?"
340     ENTER @Hp4294a;C0
350     !
360     PRINT " --- Result ---"
370     PRINT "R1 :";R1;" [ohm]"
380     PRINT "C1 :";C1;" [F]"
390     PRINT "L1 :";L1;" [H]"
400     PRINT "C0 :";C0;" [F]"
410     !
420     OUTPUT @Hp4294a;"SIMFCHAR"
430     END
```

### Statistics analysis

The Agilent 4294A allows you to analyze statistics (average, standard deviation, difference between maximum and minimum). Use the following command to turn this function ON or OFF.

- “MEASTAT” on page 338

---

#### NOTE

The statistics analysis function is available when the marker function is ON.

The applicable range for statistics analysis is the same as the range searched by the marker.

You can execute the above command to display analysis results. Use the following command to read analysis results.

- “OUTPMSTA?” on page 377

## Bandwidth analysis

The Agilent 4294A provides a trace bandwidth analysis function and allows you to analyze the active trace's bandwidth. Use the following command to turn ON this function.

- “WIDT” on page 448

---

### NOTE

The trace bandwidth analysis function is available when the marker function is ON.  
The applicable range for bandwidth search is the same as the range searched by the marker.

When the trace bandwidth analysis function is ON, you can search to the right and left of the current marker position for cutoff points. When the search is complete, submarkers 2, 3, and 1 will appear, respectively, at the leftmost and rightmost cutoff points and at the center midway between the two cutoff points.

You can use the trace bandwidth analysis function to analyze the following parameters:

- Bandwidth (*Width* in Figure 7-2)
- Sweep Parameter Value at the Center between the Two Cutoff Points (*Center* in Figure 7-2)
- Q value ( $=\text{Center}/\text{Width}$ )
- Marker-specified Measurement Parameter Values (Note, however, that one of the two different sets of parameter values appears depending on which  $\Delta$  marker is ON. When the tracking  $\Delta$  marker is ON, the marker-specified parameter values will appear. When the fixed  $\Delta$  marker is ON, those values, obtained by subtracting the fixed  $\Delta$  marker-specified values from the marker-specified values, will appear.)

---

### NOTE

Normally, trace bandwidth analysis is made when the marker searches for peaks. Therefore, the above values appear to the right of “Peak:” on the Agilent 4294A display. However, if the marker is not positioned at any of the peaks, the above values do not represent parameter values obtained at a peak.

- Value Obtained by Subtracting the Value at the Center of the Sweep Range from the Sweep Parameter Value at the Leftmost Cutoff Point (sweep parameter value when the fixed  $\Delta$  marker is ON) ( $\Delta L.F$  in Figure 7-2)
- Value Obtained by Subtracting the Value at the Center of the Sweep Range from the Sweep Parameter Value at the Rightmost Cutoff Point (sweep parameter value when the fixed  $\Delta$  marker is ON) ( $\Delta R.F$  in Figure 7-2)

Use the following command to select the method to set a cutoff point in the trace bandwidth analysis function.

- “WIDVTYPE” on page 449

If the free cutoff value setting is selected with the “WIDVTYPE” command, use the following commands to specify measurement parameters (Cutoff Value in Figure 7-2) at cutoff points:

- “WIDFVAL” on page 447

---

### NOTE

When you wish to use the “WIDFVAL” command to specify measurement parameters at cutoff points and when the  $\Delta$  marker is ON, you must remember that the value obtained by subtracting the value you enter from the  $\Delta$  marker-specified value will be specified as the measurement parameter value at the cutoff point, as shown in Figure 7-2.

Figure 7-2

Trace bandwidth analysis

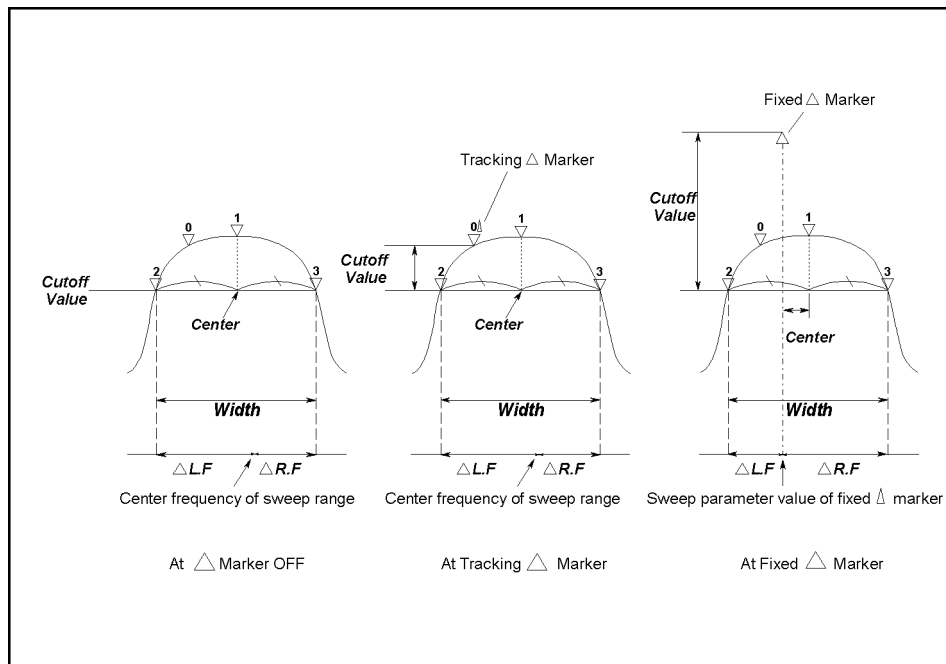

4294ape023

Use the following command to read the results of trace bandwidth analysis.

- “OUTPMWID?” on page 379

You can use the following command to search for a measurement point that meets the cutoff point requirements and that is located outside the cutoff point found during the initial search.

- “WIDSOUT” on page 448

Use the following command to return to the initial cutoff point from the measurement point found using the above command.

- “WIDSIN” on page 447

Example 7-3 shows a sample program for trace bandwidth analysis. This program is available under the filename “band\_ana.bas” on the sample program disk.

This program performs a sweep once, searches for the bandwidth, and reads and displays the results of trace bandwidth analysis.

Lines 30 to 70	Identifies the external controller and Instrument BASIC and sets the GPIB address.
Lines 90 to 110	Substitutes the sweep center value, the sweep span value, and the trace selected as the active trace into the corresponding variables Cent, Span, and Act_trc\$, respectively.
Lines 130 to 160	Resets the Agilent 4294A, sets impedance amplitude and phase as measurement parameters, and sets the sweep center value and the sweep span value to Cent and Span, respectively.
Lines 170 to 190	Performs a sweep once and waits for the sweep to be completed.
Lines 210 to 220	Sets the active trace to Act_trc\$ and executes the auto scale to automatically set the scale parameters so that the waveforms fit on the screen.

- Lines 230 to 240 Turns ON the marker function, searches for a peak, and moves the marker to the peak.
- Lines 250 to 260 Specifies the measurement parameter at the cut-off point to  $1/\sqrt{2}$  of that obtained at the marker position and then turns ON the bandwidth search function.
- Lines 270 to 280 Reads the analysis results and substitutes the obtained values into the corresponding variables B\_wid, B\_cent, B\_q, Peak, Delta\_l, and Delta\_r.
- Lines 310 to 370 Displays analysis results if the content of B\_wid is not 0.
- Line 390 Displays a message to inform you that no cutoff point has been found if the content of B\_wid is 0.

**Example 7-3**

**Trace bandwidth analysis**

```

10     DIM Act_trc$(9),Buff$(9)
20     REAL Cent,Span,B_wid,B_cent,B_q,Peak,Delta_l,Delta_r
30     IF SYSTEM$("SYSTEM ID")="HP4294A" THEN
40         ASSIGN @Hp4294a TO 800
50     ELSE
60         ASSIGN @Hp4294a TO 717
70     END IF
80     !
90     Cent=6.0E+7
100    Span=2.0E+4
110    Act_trc$="A"
120    !
130    OUTPUT @Hp4294a;"PRES"
140    OUTPUT @Hp4294a;"MEAS IMPH"
150    OUTPUT @Hp4294a;"CENT ";Cent
160    OUTPUT @Hp4294a;"SPAN ";Span
170    OUTPUT @Hp4294a;"SING"
180    OUTPUT @Hp4294a;"*OPC?"
190    ENTER @Hp4294a;Buff$
200    !
210    OUTPUT @Hp4294a;"TRAC "&Act_trc$
220    OUTPUT @Hp4294a;"AUTO"
230    OUTPUT @Hp4294a;"MKR ON"
240    OUTPUT @Hp4294a;"SEAM PEAK"
250    OUTPUT @Hp4294a;"WIDVTYPE DIVS2"
260    OUTPUT @Hp4294a;"WIDT ON"
270    OUTPUT @Hp4294a;"OUTPMWID?"
280    ENTER @Hp4294a;B_wid,B_cent,B_q,Peak,Delta_l,Delta_r
290    !
300    IF B_wid<>0. THEN
310        PRINT " --- Result ---"
320        PRINT "Width          :";B_wid;" [Hz]"
330        PRINT "Center           :";B_cent;" [Hz]"
340        PRINT "Q                 :";B_q
350        PRINT "Peak              :";Peak;" [ohm]"
360        PRINT "Delta Left        :";Delta_l;" [Hz]"
370        PRINT "Delta Right       :";Delta_r;" [Hz]"
380    ELSE
390        PRINT "Cutoff point NOT found!"
400    END IF
410    END

```

### Various analysis methods available with waveform analysis commands

The Agilent 4294A provides waveform analysis commands that allow you, for example, to search for the maximum and minimum values on the waveform and analyze waveform ripples and resonator parameters.

Use the following commands to specify the applicable range for analysis and the trace to be analyzed.

- “ANARANG” on page 259
- “ANASEGM” on page 260
- “ANARFULL” on page 260
- “ANAODATA” on page 258
- “ANAOMEMO” on page 258

Use the following command to define the peak for analysis.

- “THRR” on page 439

---

**NOTE**

The analysis range and the peak definition specified using the above commands are available only for waveform analysis commands. Note that the above range and the definition are irrelevant to the search range and the peak definition available during search using the marker or to the analysis range available during equivalent circuit analysis.

---

### Searching for maximum and minimum values

Use the following waveform analysis commands to search for and read the maximum and minimum values on the active trace.

- “OUTPMAX?” on page 373
- “OUTPMIN?” on page 375
- “OUTPMINMAX?” on page 375

You can perform the same function by using the marker search function to move the marker to each of the maximum and minimum value positions and reading the marker-specified value at each position.

---

**NOTE**

The analysis range for waveform analysis commands is specified separately from that for marker search. Therefore, one or both of the maximum and minimum values for these ranges may differ if these ranges are different.

---

### Searching for peaks

Use the following commands to search for and read peak values on the active trace.

- “PEAK?” on page 386
- “NEXPK?” on page 352
- “NPEAK?” on page 353
- “NEXNPK?” on page 351
- “LMAXS?” on page 332
- “LMINS?” on page 333

You can perform the same function by using the marker search function to move the marker to each of the peaks and reading the marker-specified value.

---

**NOTE**

The analysis range and the peak definition for waveform analysis commands are specified separately from those for marker search. Therefore, you may obtain different results if the ranges or the definitions are different.

---

**Searching for points on the trace that match specific measurement parameter values**

Use the following commands to search for a point on the active trace that matches the desired measurement parameter value and to read the sweep parameter value at that point.

- “TARR?” on page 438
- “TARL?” on page 437

You can perform the same function by using target search, one of the marker search functions, to move the marker to the position on the trace that matches the desired measurement parameter value and reading the sweep parameter value at that point.

---

**NOTE**

The analysis range for waveform analysis commands is specified separately from that for marker search. Therefore, one or both of the maximum and minimum values for these ranges may differ if these ranges are different.

---

**Analyzing ripple**

Use the following commands to analyze ripples (differences between measurement parameter values at peaks and their adjacent negative peaks) and the differences between maximum and minimum peaks on the active trace and to read the results.

- “RPLHEI?” on page 400
- “RPLLHEI?” on page 400
- “RPLRHEI?” on page 401
- “RPLPP?” on page 400
- “RPLPPS?” on page 401

**Analyzing ceramic resonator and crystal resonator parameters**

Use the following commands to analyze ceramic resonator or crystal resonator parameters and read the analysis results.

- “OUTPRESO?” on page 380
- “OUTPRESR?” on page 381
- “OUTPCERR?” on page 362
- “EQUCPARS4?” on page 302
- “EQUC0?” on page 301

---

**NOTE**

You can use these waveform analysis commands when you wish to analyze the frequency as measurement parameter and  $|Z|-\theta$  as sweep parameter.

---

See the descriptions of commands in Chapter 16 , “GPIB Command Reference,” for more

## Processing Measurement Results

### Analyzing Measurement Results

information on the parameters you can analyze.

Example 7-4 shows a sample program for ceramic resonator parameter analysis using the “OUTPCERR?” command. This program is available under the filename “ana\_com.bas” on the sample program disk.

This program performs a sweep once, uses the “OUTPCERR?” command to analyze ceramic resonator parameters, and reads and displays the analysis results.

Lines 30 to 70	Identifies the external controller and Instrument BASIC and sets the GPIB address.
Lines 90 to 120	Assigns the sweep center value, the sweep span value, the trace selected for analysis, and the peak threshold the corresponding variables Cent, Span, Ana_trc\$, and Thrr, respectively.
Lines 140 to 180	Resets the Agilent 4294A, sets impedance amplitude and phase as measurement parameters, sets the sweep center value and the sweep span value, respectively, to Cent and Span, and specifies log Y-axis format as display format.
Lines 190 to 250	Performs a sweep once and then performs the auto scale to automatically set the scale parameters so that the waveforms fit on the screen.
Lines 270 to 290	Specifies the entire sweep range as the analysis range and sets the trace selected for analysis and the peak threshold to “Ana_trc\$” and “Thrr,” respectively.
Line 300 to 310	Executes the “OUTPCERR?” command to read analyzed parameters.
Lines 330 to 380	Displays the analysis results.

#### Example 7-4

#### Ceramic Resonator Parameter Analysis

```
10 DIM Ana_trc$(9),Buff$(9)
20 REAL Cent,Span,Thrr,Zr,Fr,Za,Fa,R1,R2,R3
30 IF SYSTEM$("SYSTEM ID")="HP4294A" THEN
40 ASSIGN @Hp4294a TO 800
50 ELSE
60 ASSIGN @Hp4294a TO 717
70 END IF
80 !
90 Cent=6.0E+7
100 Span=2.0E+4
110 Ana_trc$="DATA"
120 Thrr=2.0
130 !
140 OUTPUT @Hp4294a;"PRES"
150 OUTPUT @Hp4294a;"MEAS IMPH"
160 OUTPUT @Hp4294a;"CENT ";Cent
170 OUTPUT @Hp4294a;"SPAN ";Span
180 OUTPUT @Hp4294a;"FMT LOGY"
190 OUTPUT @Hp4294a;"SING"
200 OUTPUT @Hp4294a;"*OPC?"
210 ENTER @Hp4294a;Buff$
220 OUTPUT @Hp4294a;"TRAC A"
230 OUTPUT @Hp4294a;"AUTO"
240 OUTPUT @Hp4294a;"TRAC B"
250 OUTPUT @Hp4294a;"AUTO"
```



```
260      !
270      OUTPUT @Hp4294a;"ANARFULL"
280      OUTPUT @Hp4294a;"ANAO"&Ana_trc$
290      OUTPUT @Hp4294a;"THRR ";Thrr
300      OUTPUT @Hp4294a;"OUTPCERR?"
310      ENTER @Hp4294a;Zr,Fr,Za,Fa,R1,R2,R3
320      !
330      PRINT " --- Analysis Result ---"
340      PRINT "Resonant      :";Zr;"[ohm] ",Fr;"[Hz]"
350      PRINT "Anti-Resonant:";Za;"[ohm] ",Fa;"[Hz]"
360      PRINT "Ripple L      :";R1;"[ohm] "
370      PRINT "Ripple M      :";R2;"[ohm] "
380      PRINT "Ripple R      :";R3;"[ohm] "
390      END
```

Processing Measurement Results  
**Analyzing Measurement Results**

---

## 8

# Saving/Recalling a Measurement Result/Measurement Setup

This chapter describes how to save/recall a measurement result, measurement setup, and other data into/from a file.

## Save/Recall of a File

### Specifying a location for save/recall

You can select a mass storage for saving/recalling a file from the flash disk (non-volatile), the RAM disk (volatile), or a diskette. To select a mass storage, use the following command.

- “STOD” on page 432

To change the current directory, use the following command.

- “CHAD” on page 270

### Saving data into a file

You can save a measurement result, calibration/compensation data (internal data arrays), measurement setup, and image on the LCD screen into a file.

To save one or more internal data arrays, use the following command to select the arrays you want to save.

- “SAVCAL” on page 403
- “SAVDAT” on page 404
- “SAVDTRC” on page 407
- “SAVMEM” on page 407
- “SAVMTRC” on page 408

There are 2 commands available for save to a file. The difference between these 2 commands is their file format of the save (ASCII format or binary format).

- “SAVDASC” on page 403
- “SAVDDAT” on page 404

The following command available for save a data array to a file in the touchstone format.

- “SAVDS1P” on page 405

A measurement setup is saved as an instrument state including the calibration data array, the compensation data array, and the memory array, in binary format. To save a measurement setup, use the following command.

- “SAVDSTA” on page 406

You can use the following command to save data into a file, giving it the name of AUTOREC.STA. The file having the AUTOREC.STA filename is automatically recalled at power-on.

- “SAVPSTA” on page 408

An image on the LCD screen is saved in TIFF format. To save an image on the LCD screen, use the following command.

- “SAVDTIF” on page 406

An extension is added to a filename depending on the contents of the file.

**Table 8-1**

**Filename extension**

Extension	Contents of a file
.TXT	File of a measurement result and calibration/compensation data (internal data arrays) saved in ASCII format
.DAT	File of a measurement result and calibration/compensation data (internal data arrays) saved in binary format
.STA	File of an instrument state (measurement setup and internal data arrays) saved in binary format
.TIF	File of an image on the LCD screen saved in TIFF format

A filename created when a save command is executed is as follows:

- If you specify a filename with no extension, an extension shown in Table 8-1 is added to the specified filename.
- If you specify a filename with its extension, the specified filename is used as it is.

**NOTE**

When specifying a filename using a save execution command, use a filename with no extension or a filename with the extension that matches with its contents.

When executing a file save command, you cannot specify an already existing file (in other words, you cannot update the file). To update a file, use the following command.

- “RESAVD” on page 399

**Recalling a file**

You can recall a measurement result, calibration/compensation data (internal data arrays), and measurement setup saved in a file (whose extension is “.DAT” or “.STA”) to restore its contents on the 4294A. To recall a file, use the following command.

- “RECD” on page 395

**NOTE**

To recall the contents of a file, specify a filename with its extension.

### **Copying/deleting a file**

To copy a file, use the following command.

- “FILC” on page 305

To delete a file, use the following command.

- “PURG” on page 395

---

**NOTE**

To copy/delete a file, specify a filename with its extension.

### **Creating a directory**

To create a directory, use the following command.

- “CRED” on page 276

---

## Sample Program for Save/Recall

Example 8-1 shows a sample program to save a file. This program is stored on the sample program disk as the file\_sav.bas file.

This program sets the save destination mass storage to the flash disk and saves data the user specified using a user specified filename.

Lines 40 to 80	Identifies the external controller and Instrument BASIC and sets the GPIB address.
Line 100	Sets the mass storage to the flash disk.
Line 110	Uses the Inp_file_name subprogram to obtain a user-entered save filename and stores it in the File\$ variable.
Line 130	Allows the user to return to the entry start line and enter the data again, if an error occurs when selecting the contents of a file due to, for example, a typing error.
Lines 150 to 200	Displays the list of save items (and file formats) and prompts the user to enter the desired number (1 to 4).
Line 210	Converts the entered value to an integer and substitutes it into the Content variable.
Line 220	If the value of Content is not an integer between 1 and 4, returns to the entry start line.
Lines 250 to 500	Depending on the value of Content, substitutes the extension and the save command name into the Extension\$ variable and the Command\$ variable, respectively. If the value of Content is 2 or 3, uses the Select_array subprogram to select the saved internal data array.
Line 530	Clears the error queue.
Line 540	Creates a program message to execute the save from the Command\$ and File\$ variables and sends it to the 4294A.
Lines 550 to 560	Checks for the occurrence of an error.
Lines 580 to 600	If an error of the -257 error number has occurred (error when a filename has a problem, for example, when a file having the same name exists), prompts the user to select from “Change File Name”, “Purge File”, or “End.”
Lines 610 to 630	If “Change File Name” is selected, uses the Inp_file_name subprogram again to obtain the user-entered save filename, and returns to the save start line.
Lines 650 to 670	If “Purge File” is selected, deletes the existing file having the same filename, and returns to the save start line.
Line 690	Displays the “Save Not Complete” message.
Lines 710 to 720	If an error of the -257 error number has not occurred, displays the “Save Complete” message and the save filename.

The Inp\_file\_name subprogram in lines 790 to 910, used to enter a save filename, is described below.

## Saving/Recalling a Measurement Result/Measurement Setup

### Sample Program for Save/Recall

Line 820	Allows the user to return to the entry start line and enter the data again if an error occurs due to, for example, a typing error.
Lines 830 to 840	Prompts the user to enter a save filename (without extension) and waits for the entry of a filename.
Line 860	If the entered filename exceeds 8 characters, returns to the entry start line.
Lines 870 to 880	Displays the entered filename and waits for a conformation entry (y/n key).
Line 890	If a key other than the y key is pressed in line 880, returns to the entry start line.

The Select\_array subprogram in lines 950 to 1040, used to select the internal data arrays you want to save, is described below.

Lines 970 to 980	Prompts a conformation entry of whether to save the Array_name\$ internal data array and waits for the entry of the y key or the n key.
Line 1000	If the y key is pressed in line 980, uses the Com\$ command to enable the save of Array_name\$.
Line 1020	If a key other than the y key is pressed in line 980, uses the Com\$ command to disable the save of Array_name\$.



**Example 8-1**

**Save/recall**

```

10   DIM File$[9],Inp_char$[30],Err_mes$[50],Extension$[9],Command$[9]
20   INTEGER Content,Err_no
30   CLEAR SCREEN
40   IF SYSTEM$("SYSTEM ID")="HP4294A" THEN
50     ASSIGN @Hp4294a TO 800
60   ELSE
70     ASSIGN @Hp4294a TO 717
80   END IF
90   !
100  OUTPUT @Hp4294a;"STOD FLASH"
110  CALL Inp_file_name(File$)
120  !
130  ON ERROR GOTO Data_select
140 Data_select: !
150  PRINT "Select Saved Content"
160  PRINT " 1: State and Data"
170  PRINT " 2: Data (Binary file)"
180  PRINT " 3: Data (ASCII file)"
190  PRINT " 4: LCD Image"
200  INPUT "Input 1 to 4",Inp_char$
210  Content=IVAL(Inp_char$,10)
220  IF Content<1 OR Content>4 THEN Inp_start
230  OFF ERROR
240  !
250  SELECT Content
260    CASE 1
270      Extension$=".STA"
280      Command$="SAVDSTA"
290    CASE 2
300      PRINT "Select Data Content"
310      Select_array(@Hp4294a,"DATA TRACE","SAVDTRC")
320      Select_array(@Hp4294a,"MEMORY TRACE","SAVMTRC")
330      Select_array(@Hp4294a,"DATA","SAVDAT")
340      Select_array(@Hp4294a,"MEMORY","SAVMEM")
350      Select_array(@Hp4294a,"CAL & COMP DATA","SAVCAL")
360      Extension$=".DAT"
370      Command$="SAVDDAT"
380    CASE 3
390      PRINT "Select Data Content"
400      Select_array(@Hp4294a,"DATA TRACE","SAVDTRC")
410      Select_array(@Hp4294a,"MEMORY TRACE","SAVMTRC")
420      Select_array(@Hp4294a,"DATA","SAVDAT")
430      Select_array(@Hp4294a,"MEMORY","SAVMEM")
440      Select_array(@Hp4294a,"CAL & COMP DATA","SAVCAL")
450      Extension$=".TXT"
460      Command$="SAVDASC"
470    CASE 4
480      Extension$=".TIF"
490      Command$="SAVDTIF"
500  END SELECT
510  !
520 Save_file: !
530  OUTPUT @Hp4294a;"*CLS"
540  OUTPUT @Hp4294a;Command$&" ""&File$&""""
550  OUTPUT @Hp4294a;"OUTPERRO?"
560  ENTER @Hp4294a;Err_no,Err_mes$
570  IF Err_no=(-257) THEN
580    PRINT "Error: "&Err_mes$
590    PRINT "[C]hange File Name / [P]urge File / [E]nd"
600    INPUT "Input C or P or E",Inp_char$
610    IF UPC$(Inp_char$)="C" THEN

```

## Saving/Recalling a Measurement Result/Measurement Setup

### Sample Program for Save/Recall

```
620     CALL Inp_file_name(File$)
630     GOTO Save_file
640     END IF
650     IF UPC$(Inp_char$)="P" THEN
660         OUTPUT @Hp4294a;"PURG """"&File$&Extension$&""""
670         GOTO Save_file
680     END IF
690     PRINT "Save NOT Complete"
700     ELSE
710         PRINT "Save Complete"
720         PRINT "  Save File Name: "&File$&Extension$
730     END IF
740     !
750     END
760     !
770     ! File Name Input Function
780     !
790     SUB Inp_file_name(Inp_name$)
800         DIM Inp_char$(30)
810         ON ERROR GOTO Inp_start
820     Inp_start: !
830         PRINT "Input Save File Name (without Extension)"
840         INPUT "Name?",Inp_char$
850         Inp_name$=UPC$(Inp_char$)
860         IF LEN(Inp_name$)>8 THEN Inp_start
870         PRINT "Input Name: "&Inp_name$
880         INPUT "OK? [Y/N]",Inp_char$
890         IF UPC$(Inp_char$)<>"Y" THEN Inp_start
900         OFF ERROR
910     SUBEND
920     !
930     ! Save Array Select Function
940     !
950     SUB Select_array(@Hp4294a,Array_name$,Com$)
960         DIM Inp_char$(9)
970         PRINT "  Save "&Array_name$&" Array?"
980         INPUT "[Y]es or [N]o? Input [Y/N]",Inp_char$
990         IF UPC$(Inp_char$)="Y" THEN
1000             OUTPUT @Hp4294a;Com$&" ON"
1010         ELSE
1020             OUTPUT @Hp4294a;Com$&" OFF"
1030         END IF
1040     SUBEND
```

---

9

## Communication with External Equipment (Using the I/O Ports)

This chapter describes how to use the 8-bit I/O port and the 24-bit I/O port of the Agilent 4294A to communicate with external equipment (for example, handlers in production lines).

## Using the I/O Ports

### 8-bit I/O port

The 8-bit I/O port of the 4294A consists of the following TTL signal lines.

- OUT0 to OUT7 (8-bit output)
- IN0 to IN3 (4-bit input)
- GND (ground)

### Definition of the I/O pins

Each signal of the 8-bit I/O port is described below. Figure 9-1 shows the pin assignment diagram.

OUT 0 to 7	Signal lines that can be set freely from the controller. Use these lines to send signals from the controller to external equipment. Once signals are outputted from the controller, the states of these signal lines are not changed until the controller outputs the next signals (latched).
IN 0 to 3	Signal lines that can be read out from the controller. Use these lines to send signals from external equipment to the controller.
GND (3 pins)	Ground line.

Figure 9-1

### 8-bit I/O port

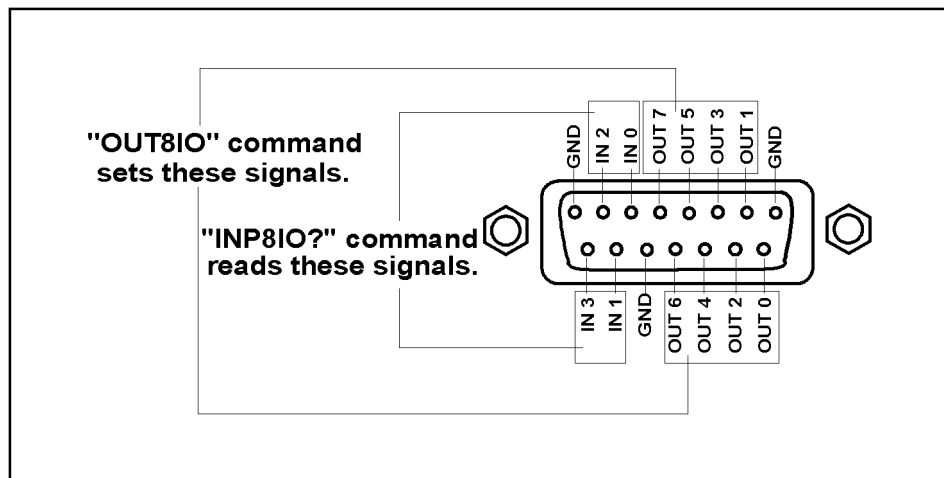

4294ape029

### 8-bit I/O port control commands

To output 8-bit data through the OUT0 to OUT7 lines, use the following command. Data is outputted as 8-bit binary, assuming that OUT0 is LSB (least significant bit) and OUT7 is MSB (most significant bit).

GPIB command	“OUT8IO” on page 357
Instrument BASIC command	“WRITEIO 15,0;”

To read out 4-bit data through the IN0 to IN3 lines, use the following command. Data is read out as 4-bit binary, assuming that IN0 is LSB and IN3 is MSB.

GPIB command	“INP8IO?” on page 308
Instrument BASIC command	“READIO(15,0)”

### 24-bit I/O port

The 24-bit I/O port of the 4294A consists of 4 independent data input/output parallel ports, several control signal lines, and a power line. All the signals provide TTL level.

The data input/output port consists of 2 sets of 8-bit output ports and 2 sets of 4-bit bi-directional ports. You can use these ports as up to a 24-bit output port or up to a 8-bit input port, by using them concurrently.

The input/output signals are preset to negative logic, but you can change the setting to positive logic. The control signal lines include the measurement completion output or control signal outputs for handshaking. Figure 9-2 shows the overview diagram of the input/output ports and the control signal lines.

**NOTE**

If a device cannot be connected directly to the 24-bit I/O interface connector on the rear panel of the 4294A, a 36-pin cable (part number: 04278-61650) is available. By connecting this cable, the distance from the 24-bit I/O interface can be extended by 1 m.

**Figure 9-2**

**Overview diagram of the 24-bit I/O port**

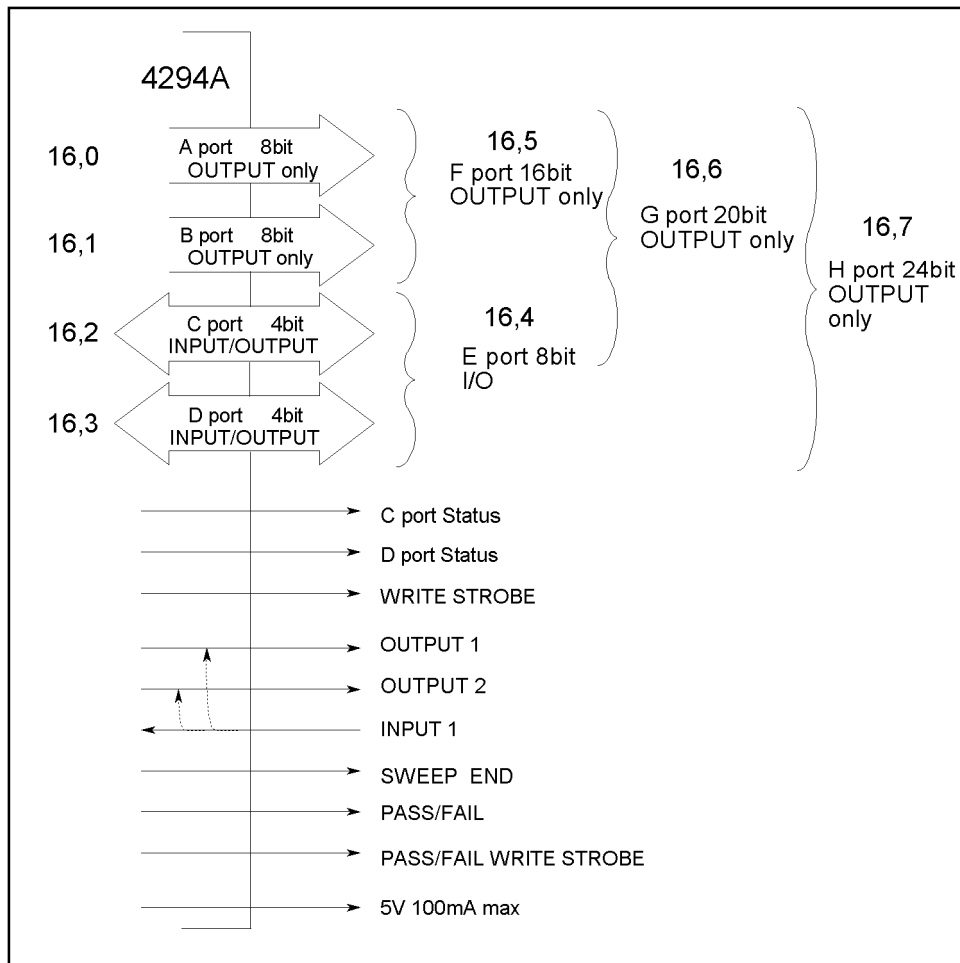

4294ape030

### Input/output port

The 24-bit I/O port of the 4294A consists of 2 sets of output ports and 2 sets of bi-directional ports as shown below.

- Output port  
Port A: 8-bit width (LSB: A0, MSB: A7)  
Port B: 8-bit width (LSB: B0, MSB: B7)

The signals provide TTL level and latched when used as output.

- Bi-directional port  
Port C: 4-bit width (LSB: C0, MSB: C3)  
Port D: 4-bit width (LSB: D0, MSB: D3)

The signals provide TTL level and latched when used as output. To select the input/output direction, use the GPIB command. At power-on, both port C and port D are set to input.

You can combine some of the above 4 ports to use them as 4 kinds of ports as shown below.

- Bi-directional port  
Port E: 8-bit width (port C + port D, LSB: C0, MSB: D3)
- Output port  
Port F: 16-bit width (port A + port B, LSB: A0, MSB: B7)  
Port G: 20-bit width (port A + port B + port C, LSB: A0, MSB: C3)  
Port H: 24-bit width (port A + port B + port C + port D, LSB: A0, MSB: D3)

### Control signal lines

The 24-bit I/O port has 9 kinds of output signal lines and 1 kind of input signal line. The signals except for the power line provide TTL level. Each signal is described below.

#### Port C status output, port D status output

Go LOW when Port C and port D are both set to input ports; HIGH when set to output ports. These output signals notify external equipment of the input/output settings of port C and port D.

#### Write strobe output for output ports

When data is outputted to one of the output ports, this write strobe output falls to indicate that data is outputted the I/O output port for external equipment. The pulse width is 10  $\mu$ s (typical). Figure 9-3 shows the relationship between the write strobe output and data output.

Figure 9-3

Relationship between the write strobe signal and data output

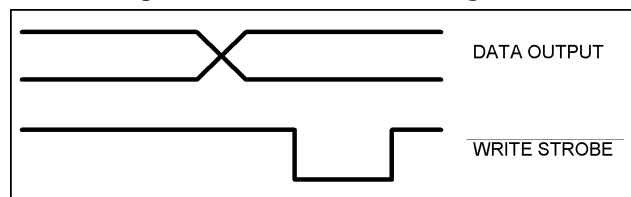

C90E001

## Communication with External Equipment (Using the I/O Ports) Using the I/O Ports

### INPUT1 input

When this input falls (a pulse is inputted), the OUTPUT1 output and the OUTPUT2 output go LOW or HIGH. The delay between the fall of the input and the state transition of both outputs is 200 ns (typical). To select LOW or HIGH of both outputs, use the GPIB command. The pulse width of a signal inputted to INPUT1 must be 1  $\mu$ s or more.

### OUTPUT1 output, OUTPUT2 output

These signal lines are latched output terminals that can be set to LOW or HIGH by a rise of the INPUT1 input or the GPIB command.

### PASS/FAIL output

Outputs HIGH (for positive logic) or LOW (for negative logic) when the limit test result is PASS; LOW (for positive logic) or HIGH (for negative logic) when FAIL. This is available only when the limit test function is on.

### Write strobe output for PASS/FAIL output

When the limit test result is outputted to the PASS/FAIL output line, a negative pulse is outputted to this write strobe output. The outputted pulse width is 10  $\mu$ s (typical). This output signal notifies external equipment that the limit test result is outputted to the PASS/FAIL output.

### SWEEP END output

Outputs a negative pulse when the 4294A completes a sweep. The outputted pulse width is 20  $\mu$ s (typical). If the continuous sweep trigger is sent, a pulse is generated each time a sweep is completed.

### +5V output

Provides a +5V output for external equipment. The maximum supply current is 100 mA. This line has no fuse, but, if over-current flows, the protection circuit of the 4294A operates and the main power to the 4294A is automatically cut off. When the cause of over-current is removed, the power to the 4294A is restored, but the instrument states are reset to the power-on states.

### Definition of I/O pins

Figure 9-4 shows pin numbers, and Table 9-1 shows the relationship between signal lines and pin numbers.

Figure 9-4

### Pin numbers of the 24-bit I/O port connector

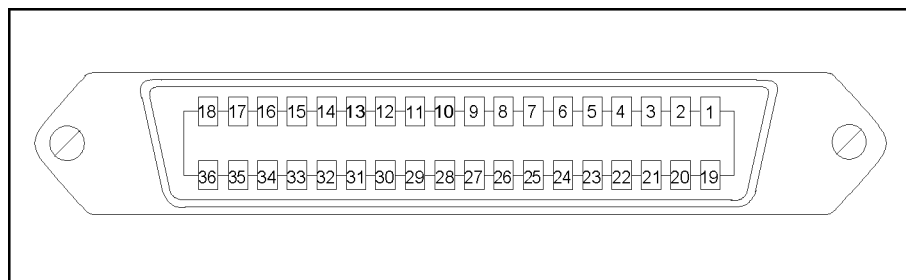

C90E003



Table 9-1

Signal assignment

Pin number	Signal name	Signal specification
1	GND	0 V
2	INPUTITTL	TTL level, pulse input (width: 1 $\mu$ s or more)
3	OUTPUT1	TTL level, latch output
4	OUTPUT2	TTL level, latch output
5	Output port A0	TTL level, latch output
6	Output port A1	TTL level, latch output
7	Output port A2	TTL level, latch output
8	Output port A3	TTL level, latch output
9	Output port A4	TTL level, latch output
10	Output port A5	TTL level, latch output
11	Output port A6	TTL level, latch output
12	Output port A7	TTL level, latch output
13	Output port B0	TTL level, latch output
14	Output port B1	TTL level, latch output
15	Output port B2	TTL level, latch output
16	Output port B3	TTL level, latch output
17	Output port B4	TTL level, latch output
18	Output port B5	TTL level, latch output
19	Output port B6	TTL level, latch output
20	Output port B7	TTL level, latch output
21	Input/output port C0	TTL level, latch output
22	Input/output port C1	TTL level, latch output
23	Input/output port C2	TTL level, latch output
24	Input/output port C3	TTL level, latch output
25	Input/output port D0	TTL level, latch output
26	Input/output port D1	TTL level, latch output
27	Input/output port D2	TTL level, latch output
28	Input/output port D3	TTL level, latch output
29	Port C status	TTL level (input mode: LOW, output mode: HIGH)
30	Port D status	TTL level (input mode: LOW, output mode: HIGH)
31	Write strobe signal	TTL level, negative logic, pulse output (width: 10 $\mu$ s; typical)
32	+5V pull-up	
33	SWEEP END signal	TTL level, negative logic, pulse output (width: 7 $\mu$ s; typical)
34	+5V	+5V, 100 mA MAX
35	PASS/FAIL signal	TTL level (PASS: HIGH, FAIL: LOW), latch output
36	PASS/FAIL write strobe signal	TTL level, negative logic, pulse output (width: 10 $\mu$ s; typical)

Basic input/output circuit

Table 9-2

Basic input/output circuit of the 24-bit I/O port

Basic circuit	Input port	
I/O pin	INPUT1	Ports C, D (input)*1
Basic circuit	Output port	
I/O pin	OUTPUT1, 2 Port A *1, B *1, C (output) *1, D (output) *1 Write strobe signal SWEEP END signal Port C status, port D status	+5V pull-up

\*1.Common to all bits

**Preset states at power-on**

The 24-bit I/O port is set at power-on as follows (not affected at reset).

Logic	Negative logic
Write strobe signal	HIGH
SWEEP END signal	HIGH
Port A	Negative 0 Æ HIGH
Port B	Negative 0 Æ HIGH
Port C	Input
Port D	Input
OUTPUT1	HIGH, HIGH at the fall of the INPUT1 input
OUTPUT2	HIGH, HIGH at the fall of the INPUT1 input
PASS/FAIL signal	(Negative) Æ HIGH

**Commands to control the 24-bit I/O port**

To output data to each output port (A to H), use the following commands.

GPIB command	Instrument BASIC command	Description
“OUTAIO” on page 358	“WRITEIO 16,0;”	Outputs 8-bit width data to port A.
“OUTBIO” on page 358	“WRITEIO 16,1;”	Outputs 8-bit width data to port B.
“OUTCIO” on page 359	“WRITEIO 16,2;”	Outputs 4-bit width data to port C.
“OUTDIO” on page 359	“WRITEIO 16,3;”	Outputs 4-bit width data to port D.
“OUTEIO” on page 360	“WRITEIO 16,4;”	Outputs 8-bit width data to port E.
“OUTFIO” on page 360	“WRITEIO 16,5;”	Outputs 16-bit width data to port F.
“OUTGIO” on page 361	“WRITEIO 16,6;”	Outputs 20-bit width data to port G.
“OUTHIO” on page 361	“WRITEIO 16,7;”	Outputs 24-bit width data to port H.

To use ports C, D, E, F, G and H as output ports, use the following commands to set ports C and D as output ports in advance.

- “COUT” on page 275
- “DOUT” on page 297

## Communication with External Equipment (Using the I/O Ports) Using the I/O Ports

To read out data from each input port (C to E) to the controller, use the following commands.

GPIB command	Instrument BASIC command	Description
“OUTPINPCIO?” on page 370	“READIO(16,2)”	Reads out 4-bit width data from port C.
“OUTPINPDIO?” on page 371	“READIO(16,3)”	Reads out 4-bit width data from port D.
“OUTPINPEIO?” on page 371	“READIO(16,4)”	Reads out 8-bit width data from port E.

To use ports C, D, and E as input ports, use the following commands to set ports C and D as input ports in advance.

- “CIN” on page 270
- “DIN” on page 287

To select positive logic or negative logic for input/output signals of ports, use the following commands. You can save this setting into an instrument setup file using the save function.

- “NEGL” on page 351
- “POSL” on page 392

---

### NOTE

The above commands, used to change the positive logic/negative logic setting, are available for the following ports.

- Output ports A to H
- Input ports C to D
- PASS/FAIL signal

---

To make the setting so that OUTPUT1 and OUTPUT2 goes HIGH (or LOW) when a pulse is inputted into INPUT1, use the following commands.

- “OUT1ENV{H|L}” on page 356
- “OUT2ENV{H|L}” on page 357

To set OUTPUT1 and OUTPUT2 to HIGH (or LOW), use the following commands.

- “OUT1{H|L}” on page 356
- “OUT2{H|L}” on page 357

To check that any pulses have been inputted to INPUT1, use the following command.

- “INPT?” on page 308

---

## Sample Program to Use the I/O Port

Communication with external equipment shows a sample program to communicate with external equipment through the 8-bit I/O. This program is stored on the sample program disk as the io\_port.bas file.

- Lines 20 to 60      Identifies the external controller and Instrument BASIC and sets the GPIB address.
- Line 80            Sets an 8-bit data value to OUT0 to OUT7 (outputs to the external equipment). In this sample, 8 is set as an 8-bit data value, and therefore the OUT3 line is set to TRUE.
- Lines 100 to 140    Waits for the external equipment to set the IN3 line to TRUE (to input 8 to IN0 to IN3 as a 4-bit data value).

### Example 9-1

#### Communication with external equipment

```
10  INTEGER Inpio, Bit3_stat
20  IF SYSTEM$( "SYSTEM ID" ) = "HP4294A" THEN
30    ASSIGN @Hp4294a TO 800
40  ELSE
50    ASSIGN @Hp4294a TO 717
60  END IF
70  !
80  OUTPUT @Hp4294a; "OUT8IO 8"
90  !
100 REPEAT
110  OUTPUT @Hp4294a; "INP8IO?"
120  ENTER @Hp4294a; Inpio
130  Bit3_stat = BIT( Inpio, 3 )
140  UNTIL Bit3_stat = 1
150  END
```

Communication with External Equipment (Using the I/O Ports)  
**Sample Program to Use the I/O Port**

---

## **10** **Handling Errors**

This chapter describes how to handle errors that may occur in the Agilent 4294A while running a program.

## Using the Status Register

Status of the 4294A can be detected using the status register. Occurrence of an error will be reflected to the standard event status register. SRQ (Service Request) is used to detect occurrence of an error in your program with information in this register.

Use the command below to detect completion of sweep via SRQ.

- “\*SRE” on page 252
- “\*ESE” on page 250

Here described is how to work with SRQ in your program.

- Step 1.** Set the 4294A to generate SRQ when “1” is assigned to the each error occurrence bit of the standard event status register.
- Step 2.** Perform an interruption processing at the time SRQ is generated.

Figure 10-1 SRQ generation sequence (in response to an error)

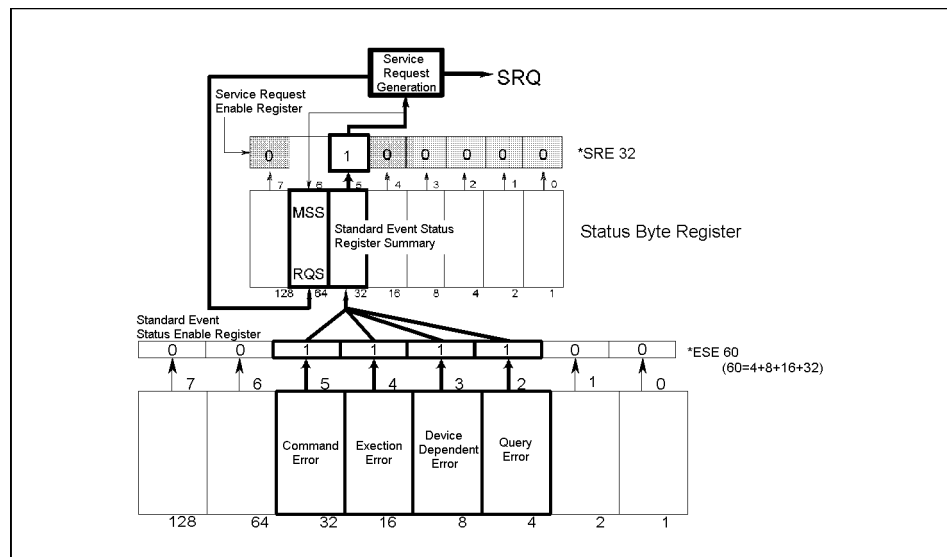

4294ape018



## Using the Error Queue

When an error occurred, its number and message will be stored in the error queue. Thus, reading contents of the error queue will enable it to verify which error occurred. Use the command below to read contents of the error queue.

- “OUTPERRO?” on page 369

Some examples for using the error queue are given below:

1. Use the error queue to branching control of the program in response to an error. If no error occurred., contents read out from the error queue is 0 for the number and “No error” for the message. This can be used to verify occurrence of any error and thus used to branch processing flow of your program. This is also used to handle a specific error which may be predefined in the program. Refer also to the examples given in Example 4-1, Example 8-1 and so on.
2. Use the error queue to identify an error when it is detected via SRQ. See the example in Example 10-1.

## Sample program for error handling

Example 10-1 is a sample program for detecting an error via SRQ. This program is saved in the file “error.bas” on the sample program disk.

This program performs necessary settings for SRQ, intentionally sends a command that the 4294A does not support to cause an error, then handles the error occurred. In the error handling, the error is identified, its error number and message are displayed followed by a message showing that the program is aborted.

Lines 30 to 90	Identifies the external controller and Instrument BASIC and sets the GPIB address and the select code.
Lines 110 to 120	Sets bit 2, 3, 4 and 5 of the standard event status register to be enabled and sets bit 5 of the service request enable register to 1.
Lines 130 to 150	Clears the status byte register, standard event status register, and error queue.
Lines 170 to 180	Defines the destination for branching by SRQ interruption and enables the SRQ interruption.
Lines 190 to 260	Sets a measurement parameter, a sweep start value, and a sweep stop value. An error occurs here because an unsupported command is used to set the start value.
Lines 290 to 300	Performs error handling. The number and message accompanied with the error is read out.
Lines 310 to 330	Displays a message showing an error has occurred, the error number, error message, and an another message telling that the program is aborted.
Line 350	Displays a message for normal termination of the program. Note that this will not be displayed unless the program is modified to employ an appropriate command for setting the start value.

**Example 10-1**      **Detecting of an error via SRQ**

```
10     DIM Buff$(9),Err_mes$(50)
20     INTEGER Scode,Err_no
30     IF SYSTEM$("SYSTEM ID")="HP4294A" THEN
40         ASSIGN @Hp4294a TO 800
50         Scode=8
60     ELSE
70         ASSIGN @Hp4294a TO 717
80         Scode=7
90     END IF
100    !
110    OUTPUT @Hp4294a;"*ESE 60"
120    OUTPUT @Hp4294a;"*SRE 32"
130    OUTPUT @Hp4294a;"*CLS"
140    OUTPUT @Hp4294a;"*OPC?"
150    ENTER @Hp4294a;Buff$
160    !
170    ON INTR Scode GOTO Err_proc
180    ENABLE INTR Scode;2
190    OUTPUT @Hp4294a;"MEAS CSQ"
200    PRINT "Set Meas Prm:Cs-Q"
210    OUTPUT @Hp4294a;"START 10MHZ"
220    PRINT "Set Start:10MHz"
230    OUTPUT @Hp4294a;"STOP 100MHZ"
240    PRINT "Set Stop:100MHz"
250    OUTPUT @Hp4294a;"*OPC?"
260    ENTER @Hp4294a;Buff$
270    GOTO Skip_err_proc
280 Err_proc: ! Error Process
290    OUTPUT @Hp4294a;"OUTPERRO?"
300    ENTER @Hp4294a;Err_no,Err_mes$
310    PRINT "Error occurred!!"
320    PRINT "  No: ";Err_no,"Description: "&Err_mes$
330    PRINT "PROGRAM INTERRUPT!!"
340    GOTO Prog_end
350 Skip_err_proc: PRINT "PROGRAM DONE."
360 Prog_end: END
```

Handling Errors  
**Sample program for error handling**

---

## 11 Using HP Instrument BASIC

This chapter gives an overview of HP Instrument BASIC and explains how to use the keyboard. Read this chapter before using the HP Instrument BASIC program installed in the Agilent 4294A.

## HP Instrument BASIC, Overview

You can use HP Instrument BASIC in a wide variety of applications from mere automation of a measurement procedure to external GPIB equipment control.

HP Instrument BASIC, although incorporated in the 4294A, works as independent system control. Thus it can communicate, using GPIB commands, with external GPIB measuring equipment, computers, peripheral devices, let alone the 4294A's main unit via the GPIB interface.

The programming interface of HP Instrument BASIC comprises an editor and programming utilities. These utilities are to save, recall, re-number programs, and to delete a program in part or in whole.

The command set of HP Instrument BASIC looks similar to that of HP BASIC. Actually, with small modifications made, HP Instrument BASIC programs can be run using HP BASIC on an external computer. See “HP Instrument BASIC Programming Technique” in *HP Instrument BASIC User's Handbook*.

---

## Controlling the Agilent 4294A

HP Instrument BASIC can control the 4294A's main unit via the internal GPIB bus. This means that 4294A has a measuring device and a controller coupled together with the GPIB bus within a case.

---

### NOTE

The select code for the internal GPIB bus is set to 8. Any internal address from 0 through 30 is valid, so the 4294A's device selector in sample programs is set to “800”.

For details of the GPIB addresses and the device selectors, see “Device Selectors” in “HP Instrument BASIC Interfacing Techniques” in *HP Instrument BASIC User's Handbook* and “Device selector” on page 28.

---

---

## Reserving an Area for BASIC on the Screen

When the 4294A is powered on, the measurement screen (ALL INSTRUMENT) shows up. The BASIC screen is made ready so as to use HP Instrument BASIC. In the 4294A, four screen layouts are available. Let's go over these four screen layouts.

**Step 1.** Press the following key and softkeys.

**[Display] - more 1/2 - ALLOCATION**

**Step 2.** Press the following softkeys.

**ALL BASIC**

The screen is cleared and the whole screen is reserved for BASIC.

**Step 3.** Press the following softkeys.

**ALL INSTRUMENT**

Then, the whole screen area is reserved for the measurement screen.

**Step 4.** Press the following softkeys.

**HALF INSTR HALF BASIC**

The upper half of the screen is reserved for the measurement screen, and the lower half is reserved for BASIC.

**Step 5.** Press the following softkeys.

**BASIC STATUS**

Three blank lines appear at the bottom of the screen. The BASIC system uses this area for taking in commands and for displaying messages.

---

## Entering BASIC Commands Using the Keys Located on the Front Panel

The 4294A HP Instrument BASIC, though with no keyboard connected, can be run with commands entered by front panel operation.

Press the following key and softkeys.

**[System] - IBASIC - more 1/3 - more 2/3 - COMMAND ENTRY**

The command entry menu appears in the soft menu area, and uppercase alphabetic letters, lowercase alphabetic letters, numerics, and specific symbols appear in the active input area. You can scroll these character sets by use of the step keys ([↑] or [↓]). Move the arrow “↑” to an intended character using the rotary knob, and press **SELECT LETTER**. Repeat these steps until you make up the character string of a command, and press **done**. The command will be run.

## Editing a Program

### Starting up and exiting edit mode

#### Starting up edit mode with key operation on the front panel

The following key operation allows you to start up edit mode regardless of the layout displayed on the screen.

**[System] - IBASIC - Edit**

#### Starting up edit mode by use of the keyboard

Enter the following command and parameter (a line number), then press the **[Enter]** key. These steps allow you to start up edit mode with the cursor displayed at the line having the specified line number. The line number may be omitted.

EDIT line number

---

**NOTE**

With the screen layout ALL INSTRUMENT selected on the screen (with the whole screen used for the measurement layout), a character string entered by the operation above will not appear on the screen, but edit mode is started up.

---

#### Exiting edit mode with key operation on the front panel

The following key operation allows you to exit edit mode.

**[System] - IBASIC - done**

#### Exiting edit mode by use of the keyboard

Press either the **[Esc]** key or the **[Home]** key, or press the **[F8]** key while holding down the **[Shift]** key and the **[Alt]** key together. This key operation allows you to exit edit mode.

## Editing a program

Here follows the way of editing a program in edit mode. For detailed information as to the keys on the keyboard, see “Keyboard” on page 154.

### Deleting characters

To delete characters, you can use the two key given below.

Backspace

The **[Back Space]** key on the front panel or the **[Backspace]** key on the keyboard deletes a single character lying on the left side of the cursor and moves the cursor to the left one character space.

Delete character

The **[Delete]** key on the keyboard deletes the character lying at the cursor positions.



### Inserting characters

In edit mode, character insertion mode is constantly ready. What you type on the keyboard is inserted at the cursor position (not in overwrite mode).

### Moving the cursor

You can move the cursor either leftward or rightward by the key operation given below.

Front panel operation	Keyboard operation
Turn the rotary knob.	Press either the [←] key or the [→] key.

### Scrolling lines

You can scroll lines up or down by the key operation given below.

Front panel operation	Keyboard operation
Press the step keys ([↑] or [↓]).	Press either the [↑] key or the [↓].

### Scrolling pages

Pressing either the [Page Up] key or the [Page Down] key on the keyboard allows you to scroll one page up or down.

### Moving to a specified line

The operation given below allows you to move the cursor to a line you specify.

**Step 1.** Carry out the following operation on the front panel.

**[System] - IBASIC - GOTO LINE**

**Step 2.** Enter a line number by use of either the front panel or the keyboard, then press the [Enter]. If labels are defined in the program, you can specify the move destination by the label instead of the line number.

### Moving to the beginning or to the tail end of a program.

Press either the [↑] key or the [↓] key while holding down the [Shift] key on the keyboard allows you to move either to the beginning or to the tail end of the program.

### Inserting, deleting, or restoring a line

Pressing the [Insert] key while holding down the [Shift] key on the keyboard inserts a new line just over the current cursor-positioned line.

Pressing the [Delete] key while holding down the [Shift] key deletes the current cursor-positioned line.

Carrying out the following key operation on the front panel allows you to restore the line you last deleted.

**[System] - IBASIC - RECALL LINE**

## Using HP Instrument BASIC

### Editing a Program

#### Clearing a line

Pressing the **[End]** key while holding down the **[Shift]** key on the keyboard allows you to delete characters from the current cursor position to the end of that line.

#### Re-numbering a line number

The procedure given below allows you to re-number a line number of the program.

**Step 1.** Carry out the following key operation on the front panel.

**[System] - IBASIC - more 1/3 - more 2/3 - RENUMBER**

or type REN by use of the keyboard.

**Step 2.** Pressing either the **[x1]** key on the front panel or the **[Enter]** on the keyboard effects the following. The first line is numbered 10 after re-numbering, the subsequent lines are numbered in increments of 10, and the whole lines are re-numbered.

To specify the first line number to be effected after re-numbering, an increment, and a re-numbering range (the first line and the last line to cover an intended range), make entries as given below, then press the **[Enter]**.

REN <para1>, <para2> IN <para3>, <para4>

where

<para1>: the first line number to be effected after re-numbering

<para2>: the increment of adjacent line numbers

<para3>: the first line number of the range to be re-numbered

<para4>: the last line number of the range to be re-renumbered.

---

## Running a Program

- Step 1.** Reserve the BASIC area. For the procedure, see “Reserving an Area for BASIC on the Screen” on page 139.
- Step 2.** Read the program that you want to execute. For the procedure, see “Reading a Program (GET)” on page 147.
- Step 3.** Carry out the following key operation on the front panel. Then the program is run.

### **[System] - IBASIC - Run**

Or type RUN on the keyboard, then press the **[Enter]** key.

## Running a program through the softkey interface

- Step 1.** Carry out the following key operation on the front panel. Then the 4294A displays a menu of softkeys that correspond to available program files residing on the selected storage device.

### **[System] - PROGRAM MENU**

- Step 2.** Select your desired program by choosing the associated softkey. Then the 4294A executes the selected program.
- Step 3.** If you want to change the storage device, press the **STORE DEV[ ]** key and then press one of the softkeys; **FLOPPY** (floppy disk), **MEMORY** (RAM disk), and **FLASH MEMORY** (flash disk).

## Automatically starting a program at power-on

A file having the “AUTOST” file name is automatically executed at power-on.

---

### **NOTE**

When the power is turned on, the 4294A checks for any “AUTOREC.STA” file. If an “AUTOREC.STA” file exists, it reads the information contained in the file, and then loads and executes the “AUTOST” program. The 4294A checks an “AUTOST” program on the floppy disk, then checks it on the flash disk.

---

## Listing a Program (LIST)

You can output a program listing either on the screen or to the printer.

### Displaying a program listing on the screen

You output a program listing on the screen as described below.

- Step 1.** Since a program listing is output on the BASIC area of the 4294A's LCD screen, you need to reserve the BASIC area before outputting a listing. For the procedure, see “Reserving an Area for BASIC on the Screen” on page 139.
- Step 2.** Type LIST on the keyboard, then press the **[Enter]** key.

### Outputting a program listing to the printer

---

**NOTE**

Check that the printer is connected to the 4294A.

- Step 1.** Type PRINTER IS PRT on the keyboard, then press the **[Enter]** key to route the output to the printer.
- Step 2.** Further, type LIST on the keyboard, and press the **[Enter]** key. Then the program listing will be output to the printer.
- Step 3.** Type PRINTER IS CRT on the keyboard, then press the **[Enter]** key to switch the output destination back to the 4294A's LCD screen.

---

## Saving a Program (SAVE)

- Step 1.** To use the built-in floppy disk drive, insert a 2DD disk or 2HD disk into the floppy disk drive. (If the disk is not initialized, initialize it in DOS format. For the procedure see *Operation Manual*.)
- Step 2.** Reserve the BASIC area. For the procedure, see “Reserving an Area for BASIC on the Screen” on page 139.
- Step 3.** Decide on which storage unit to use a floppy disk, RAM disk (volatile), or flash disk (non-volatile).

If you decide on it by use of the front panel, follow the procedure given below.

1. Carry out the key operation given below.

**[System] - IBASIC - more 1/3 - MASS STORE[]**

2. Press one of the softkeys; **FLOPPY** (floppy disk), **MEMORY** (RAM disk), and **FLASH MEMORY** (flash disk).

If you use the keyboard, enter one of the following, then press the **[Enter]** key.

- To decide on a floppy disk

MSI ":INTERNAL,4"

- To decide on a RAM disk

MSI ":MEMORY,0"

- To decide on a flash disk

MSI ":INTERNAL1,5"

- Step 4.** Type the following on the keyboard, then press the **[Enter]** key.

SAVE "file name"

---

### NOTE

If you type a file name already present on the applicable disk in saving a program, an error message “ERROR -257 File name error” appears, and the program is not saved. In this instance, you can use one of three ways given below to deal with this matter.

- Use a file name that is not present on the disk. To check the names of files held on the disk, use the CAT command.
- Overwrite an existing file with a new file by giving the same name. To overwrite a file held on the disk, use the RE-SAVE command.
- Use the PURGE command to erase the old file, and save the program as a new file.

## Listing File Names (CAT)

Here follows how to list file names saved in the storage unit (the intended disk you save a file in)

### Displaying a list of file names on the screen

- Step 1.** Since the list of file names is output on the BASIC area of the 4294A's LCD screen, you need to reserve the BASIC area before outputting the list. For the procedure, "Reserving an Area for BASIC on the Screen" on page 139.
- Step 2.** Carry out the following key operation on the front panel, then press the [X1] key. The file names will be listed.

**[System] - IBASIC - more 1/3 - CAT**

Or type CAT on the keyboard, then press the [Enter] key.

### Outputting a list of file names to the printer

---

**NOTE**

Check that the printer is connected to the 4294A.

- Step 1.** Type PRINTER IS PRT;WIDTH 80 on the keyboard, then press the [Enter] key to route the output to the printer.
- Step 2.** Further, type CAT on the keyboard, and press the [Enter] key. Then the list of file names will be output to the printer.
- Step 3.** Type PRINTER IS CRT on the keyboard, then press the [Enter] key to switch the output destination back to the 4294A's LCD screen.

---

## Reading a Program (GET)

Here follows the procedure of reading a program from the storage unit.

- Step 1.** To read a program from a floppy disk, insert it into the floppy disk drive.
- Step 2.** Reserve a BASIC area on the screen. For the procedure, see “Reserving an Area for BASIC on the Screen” on page 139.
- Step 3.** Decide on which storage unit to use a floppy disk, RAM disk (volatile), or flash disk (non-volatile).

If you decide on it by use of the front panel, follow the procedure given below.

1. Carry out the key operation given below.

**[System] - IBASIC - more 1/3 - MASS STORE[]**

2. Press one of the softkeys **FLOPPY** (floppy disk), **MEMORY** (RAM disk), and **FLASH MEMORY** (flash disk).

If you use the keyboard, enter one of the following, then press the **[Enter]** key.

- To decide on a floppy disk

MSI ":INTERNAL,4"

- To decide on a RAM disk

MSI ":MEMORY,0"

- To decide on a flash disk

MSI ":INTERNAL1,5"

- Step 4.** Type the following on the keyboard, then press the **[Enter]** key.

GET "file name"

## ON KEY LABEL Functions

HP Instrument BASIC provides you with a means to define softkeys within a program. Softkeys defined in a program will be displayed in the softkey label area if you press the **[F10]** while holding down the **[Shift]** key on the keyboard or if you press the keys **[System] - IBASIC - ON KEY LABELS** on the front panel. The labels are displayed only when the program is being run. An example is given below.

```
:  
100 ON KEY 1 GOTO 150  
110 ON KEY 2 LABEL "Print" GOSUB Report  
:
```

You can also automatically display the labels without pressing the **[Shift]** key while holding down the **[Shift]** key or without pressing the keys **[System] - IBASIC - ON KEY LABELS** on the front panel in the course of running a program. Since “KEY”(312page), one of GPIB commands, works in a manner equivalent to pressing the keys specified as parameters, the example below displays the softkeys specified by the ON KEY LABEL statement as if you press the keys **[System] - IBASIC - ON KEY LABELS**.

```
:  
200 OUTPUT @Hp4294a;"KEY 47"      ! [System] key  
210 OUTPUT @Hp4294a;"KEY 0"      ! IBASIC softkey  
220 OUTPUT @Hp4294a;"KEY 6"      ! ON KEY LABELS softkey  
:
```

For the details of the ON KEY LABEL statement, see “HP Instrument BASIC Language Reference” in *HP Instrument BASIC User's Handbook*.



---

## Pass Control Involved with an External Controller

Here follows the description of how to exchange the control priority (pass control) between Instrument BASIC and an external controller.

### Pass control

To deliver active control from an external controller to HP Instrument BASIC, execute pass control on the external controller side. For example, with the GPIB address set to 17 in the 4294A, the following in HP BASIC serves the purpose.

```
PASS CONTROL 717
```

When the 4294A has the control priority, the 4294A can specify another device on the GPIB bus to freely exchange (talk/listen) data. Similarly to the system controller, the 4294A can transmit data either to a printer or to a plotter (talk) and receive (listen) responses either from the printer or from the plotter.

---

### NOTE

The features to assert the interface clear line (IFC) and the remote enable line (REN) appertain to the system controller. Even though HP Instrument BASIC is turned to an active controller, it cannot use these features.

```
ABORT 7 Asserting Interface Clear Line (IFC)
```

```
REMOTE 7 Asserting Remote Enable Line (REN)
```

---

To return the control priority to the 4294A, execute the following on the Instrument BASIC side.

```
PASS CONTROL 721
```

Also, resetting the GPIB bus as given below causes the control priority to return to the system controller.

```
ABORT 7
```

### Communicating with an external controller

Example 11-1 shows an example of communication between an external controller and the 4294A Instrument BASIC. This example shows a program executable only on the external controller. It is given a file name `prg_xfer.bas` and is stored in the sample program disk.

This program transfers a program file saved in the external controller's storage unit (hard disk or the like) and executes the file.

Line 20	This line resets GPIB bus and returns the control priority to the system controller.
Line 30	This line sets the GPIB address.
Line 40	This line receives a user-entered file name of a program to transfer.
Lines 50 to 60	These lines delete existing programs held in Instrument BASIC, then transfer the header (the header that indicates that the size data portion hasn't been defined).
Lines 90 to 130	These lines read program lines, one by one, and transfer them.
Line 160	This line sends the signal of end of transmission (<LF>+EOI).
Line 190	This line executes the program transferred.

#### Example 11-1

#### Transferring a program to Instrument BASIC

```
10   DIM File_name$(20),Line$(1024)
20   ABORT 7
30   ASSIGN @Hp4294a TO 717
40   INPUT "FILENAME?",File_name$
50   OUTPUT @Hp4294a;"PROG:DEL:ALL"
60   OUTPUT @Hp4294a;"PROG:DEF #0"
70   ASSIGN @File TO File_name$
80   ON ERROR GOTO Done
90   LOOP
100  Line$=""
110  ENTER @File USING "K";Line$
120  OUTPUT @Hp4294a;Line$
130  END LOOP
140 Done:  !
150  OFF ERROR
160  OUTPUT @Hp4294a;" ",END
170  ASSIGN @File TO *
180  !
190  OUTPUT @Hp4294a;"PROG:EXEC ""RUN""
200  END
```

---

## Usable I/O Interfaces and Select Code

Interfaces usable in the 4294A Instrument BASIC and their select codes are as follow.

Select code	Device
1	LCD
2	Keyboard
7	External GPIB interface
8	Internal GPIB interface

---

## External RUN/CONTInue Connector

Applying a TTL-level signal to the RUN/CONT connector located on the 4294A's rear panel allows you to externally release either the RUN trigger or the CONT trigger for the program. The pulse to be applied needs to be of negative TTL level and to be not less than 20  $\mu$ sec in pulse width. The trigger is made effective at the trailing edge of the pulse.

## Displaying Graphics

You can draw graphics on the screen of the 4294A by use of HP Instrument BASIC.

the 4294A has two screens, that is, the instrument screen and the graphics screen. These screens are both always displayed on the LCD, and you cannot choose either of them to display. The instrument screen is made up of the area for displaying traces and the area for displaying softkey labels. The Instrument BASIC editor is also displayed in the area for displaying traces. The graphics screen covers the whole instrument screen as shown in Figure 11-1. The graphics screen allows what are displayed on the instrument screen to pass through as a transparent sheet, so you can draw graphics independently anywhere in the area for displaying traces and the area for displaying softkeys.

Figure 11-1

The screen makeup of the Agilent 4294A

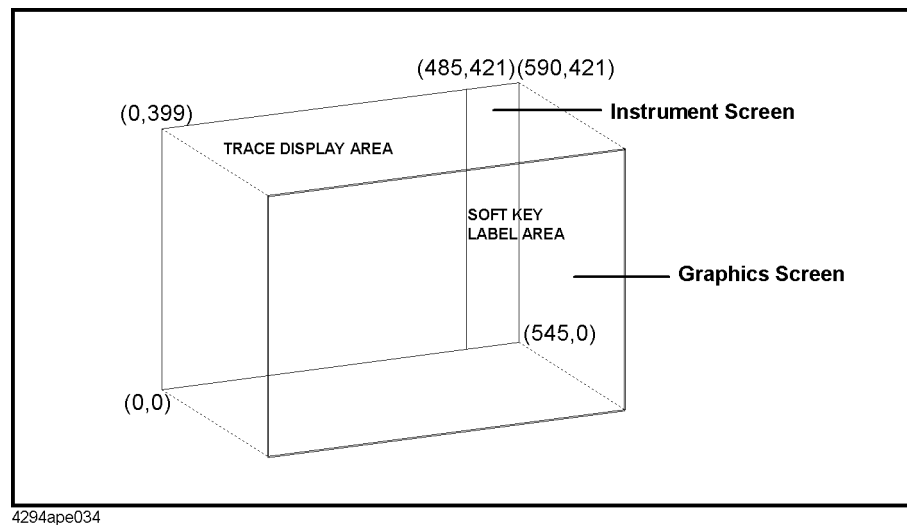

A point on the graphic screen can be specified by the coordinates shown in Figure 11-1. The lower left corner of the screen corresponds to the origin (0, 0) and the upper right corner of the screen corresponds to the point (590, 421). You give these coordinates to the parameters in the MOVE and DRAW statements.

### Graphics commands of Instrument BASIC

The 4294A HP Instrument BASIC offers three graphics-related commands; MOVE, DRAW, and GCLEAR.

MOVE	Moves the pen from the current pen position to the point specified by the coordinates given as a parameter.
DRAW	Draws a straight line from the current pen position to the point specified by the given coordinates.
GCLEAR	Clears the graphics screen, and moves the pen to the origin.

#### NOTE

After initializing the graphics screen by use of GCLEAR, you can execute the MOVE command and the DRAW command up to 1998 times. Even if you execute the MOVE command and the DRAW command after that, nothing will be drawn.

## Hard copy

You can produce hard copy output of graphics by use of the printing feature. Press the **START** key located under the **[Copy]** key.

## Default setting

The default setting when the power is turned on is as follows.

- MOVE 0,0

## A sample graphics program

Here follows a simple example to draw a line on the graphics screen.

### Drawing a straight line

The program below draws a straight line from the point (50, 200) to another (300, 200).

```
GCLEAR           ! Initializes the graphics screen.
MOVE 50,200      ! Moves the pen to the point (50, 200).
DRAW 300,200     ! Draws a straight line to the point (300, 200).
END
```

### Drawing a circle

Here follows an example of sub-program for drawing a circle. Giving coordinates of the center and a radius to this sub-programs as arguments allows you to draw a circle. Changing the start value and the end value of the parameter Theta in this sub-program allows you to draw a circular arc too.

```
SUB Drawcircle(Centx,Centy,R)  !
  DEG                          ! Uses "°" has the unit of agnle.
  X=Centx+R                    !
  Y=Centy                      !
  MOVE X,Y                    ! Moves the pen to the start point.
  For Theta=1 to 360          !
    X=INT(COS(Theta)*R+Centx) ! Calculates the x coordinate of a
point on the circle
    Y=INT(SIN(Theta)*R+Centy) ! Calculates the y coordinate of a
point on the circle.
    DRAW X,Y                  ! Draws a line to the point (X, Y)
  NEXT Theta                  !
SUBEND                        !
```

## Keyboard

Here is the description of key bindings of the keyboard.

### Character entry keys

The character keys are laid out the same as U.S. 101 keyboard. Additional features are as follows.

<b>[Caps]</b>	Pressing this key switches between uppercase characters (default) and lowercase characters.
<b>[Shift]</b>	With this key held down, uppercase characters entered turn to lowercase characters, lowercase characters entered turn to uppercase characters. When this key is pressed down, pressing a letter key produces an uppercase letter.
<b>[Enter]</b>	This key has three features. <ul style="list-style-type: none"><li>• When the program under execution requests a data entry, typing data and pressing this key in response to the request informs the program of the data entry.</li><li>• Typing the source code of a program and pressing this key stores it in memory.</li><li>• If you type a command and press this key, then the command will be executed.</li></ul>
<b>[Ctrl]</b>	Using this key in edit mode allows you to use cursor control, display control, and the Edit keys. For details, see “The [Ctrl] in edit mode” on page 158.
<b>[Backspace]</b>	Pressing this key erases a single character lying on the left side of the cursor and moves the cursor to the left one character space.
<b>[Tab]</b>	This key has no effect.

### Cursor control and display control

<b>[↑]</b> and <b>[↓]</b>	These keys scroll up or down lines in the print output area on the display. Pressing this key while holding down the <b>[Shift]</b> causes the cursor to jump to the beginning or to the tail end of the print displayed.
<b>[←]</b> and <b>[→]</b>	These keys move the cursor leftward or rightward within a line. Pressing this key while holding down the <b>[Shift]</b> key causes the cursor to jump either to the far-right position or to the far-left position of the line currently displayed.
<b>[Page Up]</b> and <b>[Page Down]</b>	Pressing these keys scrolls up or down the content of the screen page by page.

## Numeric keys

The numeric keys are useful for entering numbers and operators. Simply typing an expression in the command line and pressing the Enter key displays the result at the lower left part of the screen.

- [Enter]** This key works the same as the **[Enter]** key.
- [0]-[9]** The numeric keys work the same as those on the front panel of the 4294A.
- [Num Lock]** This key has no effect. Pressing this key turns LED on or off, but the numeric keys can be used for entering numeric values only.

## Edit keys

- [Insert]** HP Instrument BASIC constantly runs in insert mode, so this key has no effect.
- [Shift]+[Insert]** Pressing the **[Insert]** key while holding down the **[Shift]** key inserts a new line just over the cursor-positioned line (effective in edit mode only).
- [Delete]** Pressing this key deletes a single character over the cursor.
- [Shift]+[Delete]** Pressing the **[Delete]** key while holding down the **[Shift]** key deletes the cursor-positioned line (effective in edit mode only).
- [End]** Pressing this key deletes the cursor-positioned line but leaves the line number.
- [Shift]+[End]** Pressing the **[End]** key while holding down the **[Shift]** key deletes characters from the cursor position to the end of that line.
- [Home]** This key clears the alpha screen. If you are in edit mode, this key exits the edit mode.

## Program control keys

Program control keys exert control over program execution.

- [Pause/Break]** Pressing this key or pressing the **[F4]** key while holding down the **[Alt]** key temporarily stops program execution. If you carry out the key operation **[System] - IBASIC - Continue** on the front panel of the 4294A, the temporary stop is canceled.
- Pressing the **[F4]** key while holding down the **[Shift]** key and the **[Alt]** key together stops program execution. To resume executing the program, carry out the key operation **[System] - IBASIC - Run** on the front panel of the 4294A.
- [Ctrl]+[Pause/Break]** Pressing the **[Pause/Break]** key while holding down the **[Ctrl]** key resets program execution without erasing the program from memory (BASIC RESET).
- Pressing the **[F5]** key while holding down the **[Alt]** key temporarily stops the execution of the program involved in I/O operation. If the System hangs up during I/O operation, press the **[F5]** key while holding down the **[Alt]** key instead of pressing the **[Pause/Break]** key

or the key combination **[Alt]+[F4]**. The reason for this is that either the **[Pause]** key or the key combination **[Alt] + [F4]** doesn't work until the System finishes processing the current program line.

### System control keys

- [Shift]+[Page Up]** Pressing the **[Page Up]** key while holding down the **[Shift]** key calls again the program line last entered (history feature). Pressing the key combination **[Shift]+[Page Up]** repeatedly calls program lines entered in the past in reverse sequence of entries. Using this feature when you made mistakes in what you type releases you from typing them over again. Pressing the key combination **[Shift]+[Page Down]** retrieves program lines in the direction opposite to the case effected by key combination **[Shift]+[Page Up]**, and displays program lines.
- [Alt]+[F3]** Pressing the **[F3]** key while holding down the **[Alt]** key executes the program.
- [Alt]+[F2]** Pressing the **[F2]** key while holding down the **[Alt]** key cancels the temporary stop of the program.
- [F12]** With “ALL INSTRUMENT” selected for display layout, pressing the **[F12]** key switches the layout to BASIC STATUS mode. Pressing the **[F12]** key while holding down the **[Shift]** key returns the display layout to “ALL INSTRUMENT”.

### Softkeys

The function keys **[F1]** through **[F8]** work the same as the softkeys located on the front panel of the 4294A. The softkey labels are displayed on the right hand part of the screen.

### Soft control keys

- [F9]** This key turns on or off the BASIC menu to control a program and editor.
- [Shift]+[F9]** Pressing the **[F9]** key while holding down the **[Shift]** key displays the BASIC menu to control a program. Every time you press this key, the screen advances to the next page. This menu is the same as the one that appears when you carry out the key operation **[System] - IBASIC (- more 1/3 - more 2/3)** on the 4294A's front panel.
- [F10]** This key displays the first page of the BASIC menu to control a program.
- [Shift]+[F10]** Pressing the **[F10]** key while holding down the **[Shift]** key displays the ON KEY LABEL menu that displays softkeys defined in the program. For details, see “ON KEY LABEL Functions” on page 148.



**Softkeys accessed from [Shift]+[F9] key.**

Pressing the **[F9]** key while holding down the **[Shift]** key calls the BASIC menu to be used for controlling a program. Pressing this softkey allows you to run a command or to generate program source code instead of keyboard entries. Each menu item is described below.

<b>Step</b>	Executes the program line by line. Useful for debugging.
<b>Continue</b>	Cancels the temporary stop of the program.
<b>Run</b>	Runs the program.
<b>Pause</b>	Runs the instruction on the current line, then temporarily stops running the program.
<b>Stop</b>	Stops running the current line and subsequent lines. Pressing <b>Run</b> allows you to run the program from the beginning over again.
<b>Edit</b>	Turns edit mode ready.
<b>ON KEY LABELS</b>	Displays softkeys defined by the program.
<b>CAT</b>	Generates the character string "CAT " in the BASIC command line. The CAT command lists file names held in the disk.
<b>SAVE</b>	Generates the character string "SAVE "" in the BASIC command line. The SAVE command saves a program in the form of ASCII file.
<b>RE-SAVE</b>	Generates the character string "RE-SAVE "" in the BASIC command line. RE-SAVE overwrites a specified file with the program. Use this to update an old file.
<b>GET</b>	Generates the character string "GET "" in the BASIC command line. The GET command loads a specified ASCII file and reads it into editor's memory.
<b>PURGE</b>	Generates the character string "PURGE "" in the BASIC command line. The PURGE command erases a specified file.
<b>INITIALIZE</b>	Generates the character string "INITIALIZE " in the BASIC command line. The INITIALIZE command formats the disk so that the disk turns ready for use. If you execute this command, the contents of the disk will be fully lost.
<b>MASS STORE []</b>	Displays the menu for choosing a BASIC storage unit.
<b>SCRATCH</b>	Generates the character string "SCRATCH " in the BASIC command line. If you press the <b>[Enter]</b> key in succession, the program handled in the editor will be erased from memory.
<b>RENUMBER</b>	Generates the character string "REN " in the BASIC command line. If you press the <b>[Enter]</b> key in succession, the program line will be re-numbered.
<b>LIST</b>	Generates the character string "LIST " in the BASIC command line. The LIST command outputs a program listing on the screen.
<b>COMMAND ENTRY</b>	Displays the softkeys to be used for entering BASIC commands.
<b>CLEAR I/O</b>	Stops I/O operation currently being carried out.
<b>RESET LABELS</b>	Resets IBASIC (BASIC reset).

### The [Ctrl] in edit mode

Pressing a certain key while holding down the [CTRL] key in edit mode works equivalently to one of the control keys such as [↑], [↓] or [Insert]. Description of how these keys work is given below.

Key operation	Working
[Ctrl]+[a]	Moves the cursor to the beginning of the line. (Equivalent to [Shift]+[↑])
[Ctrl]+[b]	Moves the cursor backward one character space. (Equivalent to [←])
[Ctrl]+[d]	Erases the character over the cursor. (Equivalent to [Delete])
[Ctrl]+[e]	Moves the cursor to the end of the line. (Equivalent to [Shift]+[→])
[Ctrl]+[f]	Moves the cursor rightward one character space. (Equivalent to [→])
[Ctrl]+[g]	Causes the cursor to jump to an arbitrary line or to an arbitrary label. Specify either a line number or a label subsequent to [Ctrl]+[g]. (Equivalent to GOTO LINE)
[Ctrl]+[h]	Erases one character lying at the left of the cursor. (Equivalent to [Backspace])
[Ctrl]+[j]	Works equivalently to the [Enter] key.
[Ctrl]+[k]	Erases characters from the cursor position to the end of the line. (Equivalent to [Shift]+[End])
[Ctrl]+[m]	Works equivalently to the [Enter].
[Ctrl]+[n]	Moves the cursor to the next line. (Equivalent to [↓])
[Ctrl]+[o]	Inserts a line just over the cursor-positioned line. (Equivalent to [Shift]+[Insert])
[Ctrl]+[p]	Moves the cursor to the preceding line. (Equivalent to [↑])

### Displaying program execution status

Here follows the description of the program status displayed at the lower right part of the screen.

What is displayed	Program status
None	Program completed. Possible to run a command. CONTINUE not usable.
_	Program stopped. Possible to run a command. CONTINUE not usable.
?	The program is waiting a keyboard entry. Not possible to run a command.
*	This mark is displayed in one of two cases given below. <ul style="list-style-type: none"> <li>Running a command. Not possible to run a command. CONTINUE not usable.</li> <li>Running a command entered from the keyboard. Not possible to run a command.</li> </ul>

---

## Instrument BASIC Commands Specific to the Agilent 4294A

The commands given below are not carried on “HP Instrument BASIC Language Reference” in *HP Instrument BASIC User's Handbook*, but they are available on HP Instrument BASIC of the 4294A. They can be run both by use of the keyboard and within programs. They, if used in a program, can be used in a single IF ... THEN ... line.

### DATE

This function converts a date (day, month, year) into Julian seconds.

- Examples of use

```
PRINT DATE("21 MAY 1991")           ! Indicates Julian seconds
corresponding to May 21, 1991.
SET TIMEDATE DATE("1 Jan 1991")     ! Sets 00:00 a.m. January 1, 1991
! in the real time clock.
Days=(DATE("1 JAN 1991")-DATE("11 NOV 1990")) DIV 86400  !
```

---

### NOTE

Julian second is a value expressed in seconds counted since 00:00 a.m. November 24, 4713 B.C. to be used in the real time clock.

---

### DATES

This function converts Julian seconds into its corresponding date (day, month, year).

- Examples of use

```
PRINT DATE$(TIMEDATE) ! Indicates the date set in the real time clock.
DISP DATE$(2.111510608E+11) ! Indicates the date corresponding to
! 2.111510608E+11 Julian seconds.
```

## READIO

This command reads the content of I/O ports.

Syntax: READIO(<numerical 1>,<numerical 2>)

Parameter	Description	Range of setting
<numeric 1>	Select code	One of 15, and 16 15: 8-bit I/O port 16: 24-bit I/O port
<numeric 2>	Register number	With the select code set to 15: 0 only With the select code set to 16: 2 to 4

- Example of use

```
Ioport=READIO(15,0) ! Assigns data in the 8-bit I/O port to  
! the variable Ioport.
```

## SET TIME

This statement changes nothing but the time set in the real time clock (internal clock).

- Examples of use

```
SET TIME TIME("22:00:30") ! Changes the time set in  
! the real time clock to 22:00:30.  
SET TIME Hours*3600+Minutes*60 ! Changes the time set in  
! the real time clock to Hours:Minutes.
```

## SET TIMEDATE

This statement changes Julian seconds set in the real time clock (internal clock).

- Example of use

```
SET TIMEDATE DATE("4 JAN 1993")+TIME("10:00:00") ! Set the real time  
! clock to 10 a.m.  
! January 4, 1993.  
SET TIMEDATE TIMEDATE+86400 ! Sets the real time  
! clock forward one day.
```

## TIME

This function indicates the elapsed time from 00:00 a.m. in seconds.

- Examples of use

```
Seconds=TIME("8:37:20")      ! The elapsed time expressed in seconds
                              ! from 00:00 a.m. to 08:37:20 a.m.
SET TIME TIME("8:37:20")    ! Sets the real time clock to 08:37:20.
ON TIME TIME("12:10") GOSUB Lunch ! Jumps to Lunch when 12:10 comes.
```

## TIMES

This function returns the elapsed time from 00:00 a.m. in the form of HH:MM:SS.

- Examples of use

```
DISP "The time is: ";TIME$(TIMEDATE) ! Current time set in the real
                                      ! time clock.
PRINT TIME$(45296)                  ! The time after an elapse of
                                      ! 45296 seconds from 00:00 a.m.
```

## WRITEIO

This statement writes data either to I/O ports or to the registers for the EXECUTE command.

Syntax: WRITEIO <numeric 1>,<numeric 2>; <numeric 3>

Parameter	Description	Range of setting
<numeric 1>	Select code	One of 15, and 16 15: 8-bit I/O port 16: 24-bit I/O prot
<numeric 2>	Register number	With the select coded set to 15: 0 only With the select code set to 16: 0 to 7
<numeric 3>	Data in the register	With the select code set to 15: 0 to 255 With the select code set to 16: 0 to 16777215

- Examples of use

```
WRITEIO 15,0;12              ! Writes 12 to the 8 bit I/O port.
```

## Instrument BASIC Commands that Cannot be Run on the Agilent 4294A

The commands given below are carried on “HP Instrument BASIC Language Reference” in *HP Instrument BASIC User's Handbook*, but they cannot be run on HP Instrument BASIC of the 4294A.

- OFF CYCLE
- ON CYCLE

---

### NOTE

The GCLEAR command and the ON TIMEOUT command have the following feature and limitation besides those described in “HP Instrument BASIC Language Reference” in *HP Instrument BASIC User's Handbook*.

- GCLEAR  
Moves the pen to the origin (0,0).
- OFF TIMEOUT and ON TIMEOUT

The interface select code can be set to 7 only.

---

---

## 12 Using LAN

This chapter describes LAN (Local Area Network)-based file transfer and remote control.

## Advantages of LAN Connection

You can connect the Agilent 4294A with LAN. Connecting it with LAN allows you to make use of the functions given below.

- You can easily transfer files between an external computer and the 4294A.
  - You can transfer files held in the 4294A to an external computer or vice versa bypassing floppy disks.
  - You can directly save settings or measurement data held in the 4294A into an external computer. You can also recall files of settings held on an external computer into the 4294A.
- The 4294A You can save Instrument BASIC programs held in the 4294A editor into an external computer. You can also download the files of Instrument BASIC programs to the 4294A editor and execute them.
- You can send GPIB commands to the 4294A and control it.

---

**NOTE**

You cannot use some of functions usable within GPIB, such as service request, by way of LAN.

---



---

## Getting Ready for Using LAN

### Getting ready for LAN connection

Before connecting the 4294A with LAN, you set an IP address (a unique address within a single LAN assigned to a device to identify it in making LAN connection), a gateway IP address (the IP address of a routing device that connects your the 4294A's LAN with other LANs), and a sub-net mask (a numerical value used to judge whether your the 4294A needs to route communications through the gateway).

---

**NOTE** Obtain the settings of IP address, gateway address, and sub-net mask from your network administrator.

---

---

**NOTE** If your network doesn't need to be connected with devices on different physical networks, usually you need to set neither the gateway IP address nor the sub-net mask.

---

---

**NOTE** To validate the IP address, the gateway IP address, and the sub-net mask you set, you need to cycle power of the 4294A (power it off and power it on again).

---

### Setting an IP address

Here follows the way of setting an IP address.

- Step 1.** Press the [**Local**] key in the INSTRUMENT STATE block on the front panel, and press the **IP ADDRESS** key.
- Step 2.** Press the **1st** key, and enter the first number of the IP address delimited by a period.
- Step 3.** Press the **2nd** key, the **3rd** key, and the **4th** key, and similarly enter the second, the third, and the fourth numbers of the IP address delimited by a period.
- Step 4.** Press the **done** key.

To make settings with the GPIB command, use the command given below.

- “ADDRIP” on page 257

## Using LAN

### Getting Ready for Using LAN

#### Setting a gateway IP address

Here follows the way of setting a gateway IP address.

- Step 1.** Press the [**Local**] key in the INSTRUMENT STATE block on the front panel, and press the **GATEWAY ADDRESS** key.
- Step 2.** Press the **1st** key, and enter the first number of the gateway IP address delimited by a period.
- Step 3.** Press the **2nd** key, the **3rd** key, and the **4th** key, and similarly enter the second, the third, and the fourth numbers of the gateway IP address delimited by a period.
- Step 4.** Press the **done** key.

To make settings with the GPIB command, use the command given below.

- “ADDRGW” on page 256

#### Setting a sub-net mask

Here follows the way of setting a sub-net mask.

- Step 1.** Press the [**Local**] key in the INSTRUMENT STATE block on the front panel, and press the **SUBNET MASK** key.
- Step 2.** Press the **1st** key, and enter the first number of the sub-net mask delimited by a period.
- Step 3.** Press the **2nd** key, the **3rd** key, and the **4th** key, and similarly enter the second, the third, and the fourth numbers of the sub-net mask delimited by a period.
- Step 4.** Press the **done** key.

To make settings with the command, use the command given below.

- “SUBNET” on page 434

#### Displaying the MAC address

In the event that you need to look up the MAC address (a unique address assigned to the device) of the 4294A, follow the steps given below, the MAC address will be displayed on the LCD screen.

- Step 1.** Press the [**System**] key in the INSTRUMENT STATE block on the front panel, and press the **DIAGNOSTIC TEST** key.
- Step 2.** Pressing the **MAC ADDRESS** key causes the MAC address of the 4294A to appear on the LCD screen.

#### Connecting with LAN

Use a 10Base-T twisted pair (Ethertwist) cable to connect the LAN port (RJ-45 connector) located at the lower left of the 4294A's rear panel with a vacant port of the LAN in view.

## Transferring Files

You can transfer files from the 4294A, if connected to LAN, to an external computer connected to the same LAN or vice versa by use of FTP (file transfer protocol).

### NOTE

The description given below assumes that you are familiar with the basic operation in a Window environment, such as Windows 95, Windows NT, and so on, and that you have basic knowledge about the operation of MS-DOS. For questions as to the operation of Windows 95 or other environment, see appropriate references.

### File transfer procedure using ftp

A file transfer procedure that uses ftp (an FTP-based file transfer program) is described here by taking up an example in which you transfer a file (name: `ex_pc.sta`) located on the external computer in a Windows environment to the flash memory (non-volatile memory) of the 4294A (IP address: 1.10.100.50, host name: `hp4294a`) and you transfer a file (name: `ex_ins.sta`) located on the flash memory of the 4294A to an external computer.

- Step 1.** Start up the screen in which the MS-DOS prompt is ready.
- Step 2.** Move to the directory in which `ex_pc.sta` is stored.
- Step 3.** At the MS-DOS prompt, type either `ftp 1.10.100.50` or `ftp hp4294a`, and press the Return key.
- Step 4.** Pressing the Return key twice causes the ftp prompt to appear.

### NOTE

The file system of the 4294A is provided with neither user name protection nor password protection. Therefore, you can login as any user name without password for the account.

- Step 5.** Type `dir` at the ftp prompt and press the Return key, then a list of directories appears. The directories displayed correspond to the built-in storage units of the 4294A given below. For the dynamic data disk, see “Saving/Recalling a File in/from an External Computer” on page 171.

<code>data</code>	Dynamic data disk
<code>int</code>	Built-in floppy disk drive
<code>nvr</code>	Built-in flash memory disk (non-volatile memory)
<code>ram</code>	Built-in RAM disk (volatile memory)

- Step 6.** Type `cd nvr` at the ftp prompt and press the Return key to move to the flash memory.
- Step 7.** Type `binary` at the ftp prompt and press the Return key. This step sets file transfer mode to binary form.

### NOTE

Choose a file transfer mode in conformity with a file you transfer. That is, set the mode to ASCII form when dealing with a file having the extension “.TXT” or a program file in Instrument BASIC, otherwise set the mode to binary form.

## Using LAN Transferring Files

- Step 8.** Type `put ex_pc.sta` at the ftp prompt and press the Return key. This completes the transfer from an external computer to flash memory.
- Step 9.** Type `get ex_ins.sta` at the ftp prompt and press the Return key. This completes the transfer from flash memory to an external computer.
- Step 10.** Type `quit` at the ftp prompt and press the Return key to quit ftp.

The chief commands used in ftp are briefly described below.

<code>get</code>	Transfers (Copies) a specified file from the current directory of the ftp server (the 4294A for the example above) to the ftp client (an external computer for the example above)
<code>put</code>	Transfers (Copies) a specified file from the ftp client to the ftp server's current directory.
<code>binary</code>	Sets file transfer mode to binary form.
<code>ascii</code>	Sets file transfer mode to ASCII form.
<code>cd</code>	Moves from the current directory to another.
<code>dir</code>	Lists the content of the current directory.
<code>quit</code>	Quits ftp.

## File transfer procedure using a file transfer application

Using a file transfer application in a Windows environment allows you to easily transfer files thanks to the mouse. A general operation procedure in which such an application is used is briefly given below.

- Step 1.** Start up an applicable file transfer application. A screen as it is before connecting the 4294A (a screen like Figure 12-1, for example) appears.

Figure 12-1

A sample screen of file transfer application (before connecting with the 4294A)

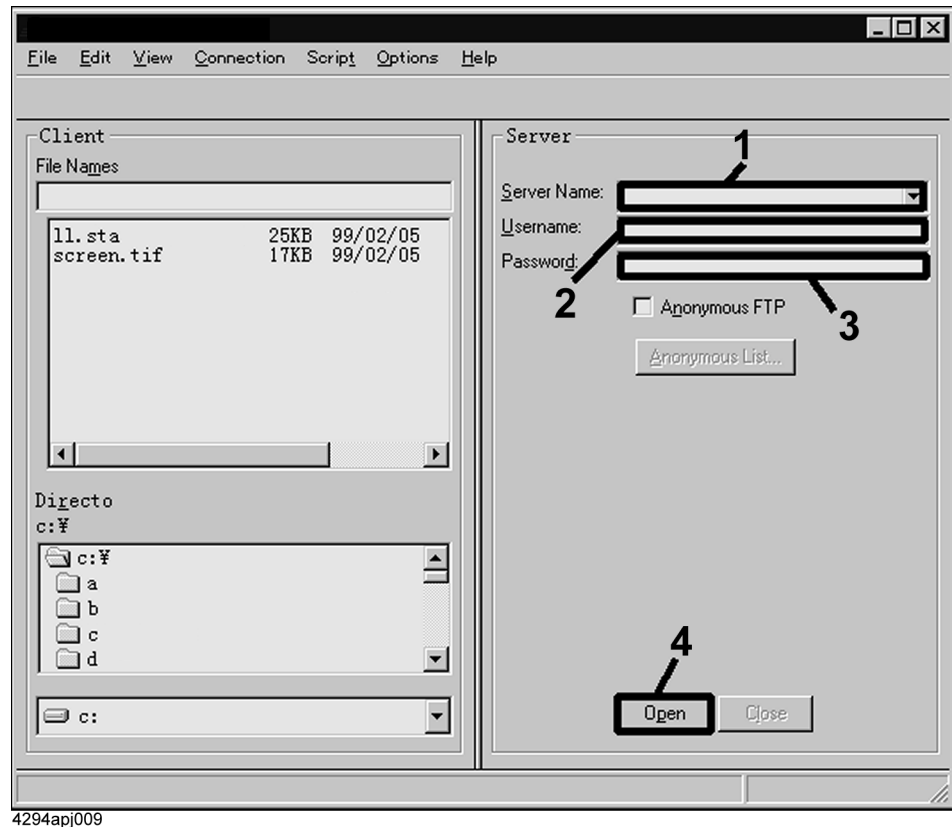

- Step 2.** Enter the IP address of the 4294A in the Server Name field (the field labeled 1 in Figure 12-1), enter suitable character(s) (any character(s) other than blank character(s)) in the User Name field (the field labeled 2 in Figure 12-1). You can leave the Password field (the field labeled 3 in Figure 12-1) blank.
- Step 3.** If you start connecting with the server (the 4294A) (click the button labeled 4 in Figure 12-1), then the content of the file system of the 4294A appears as shown in Figure 12-2.

Figure 12-2

A sample screen of file transfer application (after connected with the 4294A)

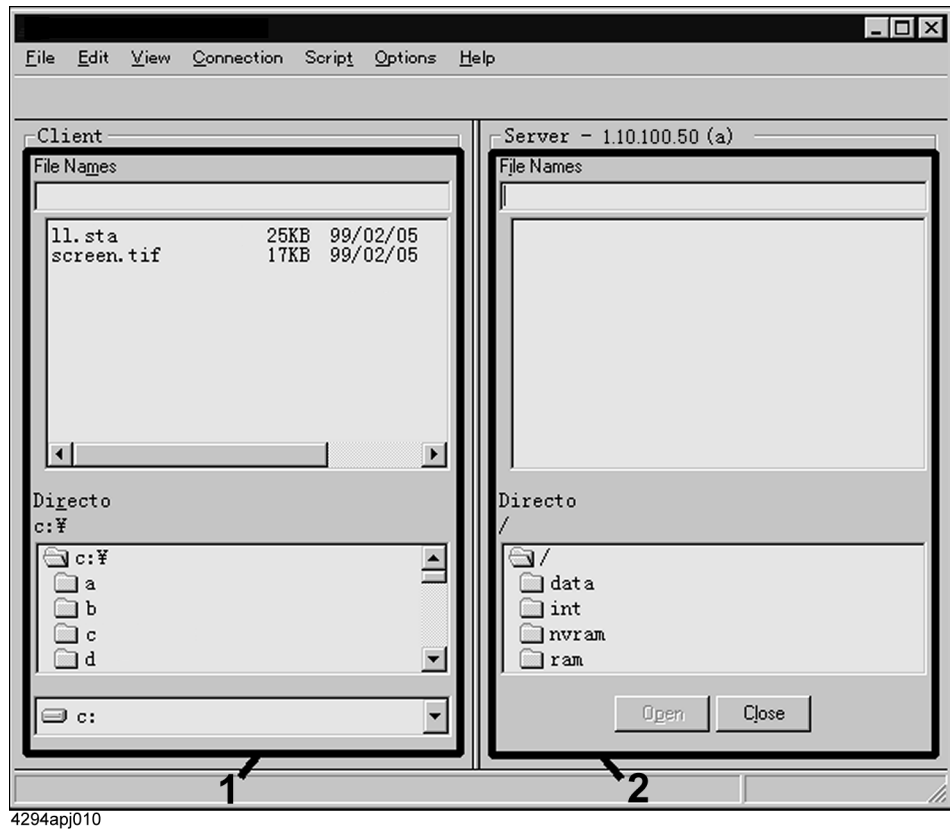

- Step 4.** Copy files, similarly to the usual procedure for copying files by use of Windows 95 Explorer, from the external computer side (the window labeled 1 in Figure 12-2) to the 4294A side (the window labeled 2 in Figure 12-2), or from the 4294A side to the external computer.

---

## Saving/Recalling a File in/from an External Computer

The dynamic data disk of the 4294A holds measurement data together with virtual files to be used to read the state of equipment settings or to make settings. Accessing from an external computer to files held in the dynamic data disk of the 4294A by use of ftp allows you to directly save/recall measurement data, files of equipment settings, or Instrument BASIC programs in/from an external computer.

That is, transferring files held in the dynamic data disk to an external computer brings about a result equivalent to carrying out the series of steps given below.

1. Saves measurement data, the state of equipment settings, or Instrument BASIC programs to files held in flash memory.
2. Transfers files saved in flash memory to an external computer.
3. Erases files held in flash memory.

Transferring files, such as measurement data, the state of equipment settings, etc., held on an external computer using virtual file names (see Table 12-1) brings about a result equivalent to carrying out the series of steps given below.

1. Transfers files held on an external computer to flash memory.
2. Either recalls transferred files or gets them in Instrument BASIC. (Executes the obtained programs in the case of prog\_run.bas.)
3. Erases the files held in flash memory.

---

### NOTE

At the time you list the files in a directory by use of the dir command of ftp, or at the time you access the dynamic data disk, certain files are created temporarily in flash memory. Thus there can be instances in which you cannot list files or access the dynamic data disk if sufficient free space (more than the aggregate size of the files transferred) is not available in flash memory.

---

### NOTE

The dynamic data disk is a directory in which virtual files for FTP transfer are stored, so you cannot access the dynamic data disk by use of the usual file saving/recalling operation from the front panel or by use of the GPIB command.

Table 12-1 shows virtual files in the dynamic data disk and workings of file transfer.

Table 12-1

### Virtual files held in the dynamic data disk and the workings of file transfer

File name	get/put <sup>*1</sup>	Description
state.sta	get	Saves the current settings and internal data arrays of the 4294A in files held on an external computer.
	put	Recalls the files held on an external computer containing the settings and internal data arrays into the 4294A.
data.dat	put	Recalls data files (files which were transferred by “get” of data_cal.dat, data_d.dat, data_m.dat, data_dt.dat, data_mt.dat or internal data array files which were got using the save/recall function) held on an external computer into the 4294A. The internal data arrays (calibration data, data, memory, data trace, memory trace) contained in the files are recalled.
data_cal.dat	get	Saves the current calibration data arrays and compensation data arrays of the 4294A to files held on an external computer in binary form. <sup>*2</sup> The file name when you recall (“put”) the got file to the 4294A is data.dat.
data_d.dat	get	Saves the current data arrays of the 4294A in files held on an external computer in binary form. The file name when you recall (“put”) the got file to the 4294A is data.dat.
data_m.dat	get	Saves the current memory arrays of the 4294A in files held on an external computer in binary form. The file name when you recall (“put”) the got file to the 4294A is data.dat.
data_dt.dat	get	Saves the current data trace arrays of the 4294A in files held on an external computer in binary form. The file name when you recall (“put”) the got file to the 4294A is data.dat.
data_mt.dat	get	Saves the current memory trace arrays of the 4294A in files held on an external computer in binary form. The file name when you recall (“put”) the got file to the 4294A is data.dat.
prog.bas	get	Saves a Instrument BASIC program held on the 4294A in an external computer in ASCII form. <sup>*3</sup>
	put	Downloads a Instrument BASIC programs saved in an external computer in ASCII form to Instrument BASIC of the 4294A. <sup>*3</sup>
prog_run.bas	put	Downloads Instrument BASIC program saved in an external computer in binary form to Instrument BASIC of the 4294A, and runs it. <sup>*4</sup>
screen.tif	get	Saves what are displayed on the LCD screen in a file held on an external computer in TIFF format.
data_cal.txt	get	Saves the current calibration data arrays and compensation data arrays of the 4294A in files held on an external computer in ASCII form. <sup>*2</sup>
data_d.txt	get	Saves the current data arrays of the 4294A in files held on an external computer in ASCII form.
data_m.txt	get	Saves the current memory arrays of the 4294A in files held on an external computer in ASCII form.
data_dt.txt	get	Saves the current data trace arrays of the 4294A in files held on an external computer in ASCII form.
data_mt.txt	get	Saves the current memory trace arrays of the 4294A in files held on an external computer in ASCII form.

\*1.get: Transfers files from the 4294A to an external computer

put: Transfers files from an external computer to the 4294A.



**Saving/Recalling a File in/from an External Computer**

- \*2.If user calibration data haven't been measured or haven't been entered by use of applicable commands, the values of calibration arrays will not be contained in the files saved.
- \*3.This operation is ignored if an Instrument BASIC program is being edited or run on the 4294A.
- \*4.If an Instrument BASIC program is being edited or run on the 4294A, the process of editing or running is suspended, and Instrument BASIC is reset, then the programs are downloaded and run.

## Controlling the Agilent 4294A

You can control the 4294A, if connected to LAN, from an external controller. The communication between an external controller and the 4294A is achieved by means of connecting sockets created by individual processes and by forming a network path between the process of the external controller and that of the 4294A. The sockets are endpoint nodes of network connection, and Port 23 and Port 5025 are ready for use as the sockets on the 4294A side. Port 23 is for interactive control using telnet (a user interface program based on the TELNET protocol), and displays a welcome message (Welcome to the 4294A) when connection is established. Port 5025 is prepared to be used from a program, and displays no welcome message.

You can also control the 4294A, by use of the dynamic data disk and Instrument BASIC programs described earlier.

### Control by use of sockets

#### Interactive control by use of telnet

A control procedure that uses telnet is described here by taking up an example in which you control the 4294A (IP address: 1.10.100.50, host name: hp4294a) from an external computer installed in a Windows environment.

- Step 1.** Start up the screen in which the MS-DOS prompt is ready.
- Step 2.** At the MS-DOS prompt, type either `telnet 1.10.100.50` or `telnet hp4294a`, and press the Return key.
- Step 3.** The telnet screen is started up, and a welcome message “Welcome to the 4294A” appears on the screen. (In a UNIX environment, a welcome message appears under the line in which you typed `telnet 1.10.100.50`.)
- Step 4.** Enter a command under the welcome message and press the Return key, then the command is sent to the 4294A and run. Enter a Query command and press the Return key, then a Query response is displayed. Figure 12-3 shows the screen that appears after you reset the 4294A by use of the “PRES” command (page 393), set the sweep start point and end point to 10 MHz and 20 MHz respectively by use of the “STAR” command (page 431) and “STOP” command (page 433), and checked these settings.

Figure 12-3 An example of control using telnet

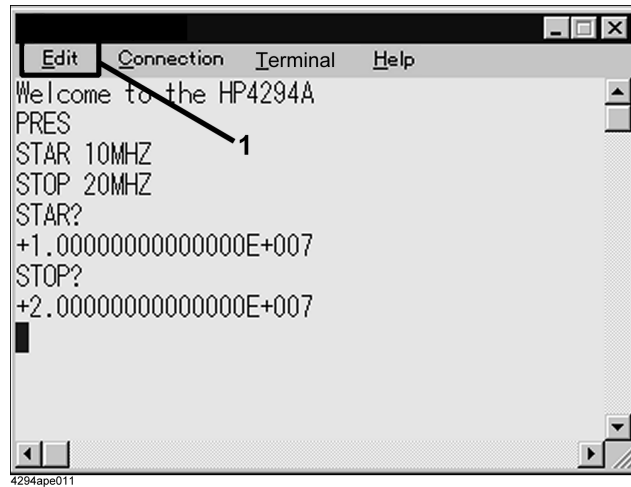

- Step 5.** Selecting “Disconnect” in the Connection menu on the telnet screen (1 in Figure 12-3) breaks the connection with the 4294A, then you select “Quit” in the Connection menu to quit telnet. (In a UNIX environment, typing `]` key while holding down the Control key causes the telnet prompt to appear, so typing `quit` at the telnet prompt breaks the connection with the 4294A and quits telnet as well.

**NOTE**

Two transfer modes are available in telnet.

In line mode, pressing the Return key sends characters entered up to that time to the 4294A. That is, characters are sent line by line. Thus if you make a mistake in typing a command, you can correct it by use of the Backspace key.

In character mode, a character typed is sent to the 4294A, that is, characters are sent one by one. Thus if you make a mistake in typing a command, it has already been sent, so you cannot use the Backspace key any longer to correct your mistake.

If telnet you use is an application in which you can choose between transfer modes, choose one according to your situation. For example, in the case of telnet in a UNIX environment, typing `]` key while holding down the Control key causes the telnet prompt to appear; at the telnet prompt, type either `mode line` (to choose line mode) or `mode character` (to choose character mode) and press the Return key to decide on which mode to use.

## Using LAN Controlling the Agilent 4294A

### Control from a program

To control the 4294A from a program stored on an external controller, make connection by use of the socket of Port 5025.

---

**NOTE**

You cannot use some of functions usable within GPIB, such as service request, by way of LAN.

---

### Control with HP VEE

In HP VEE, using To/From Socket makes connection with the socket of Port 5025 so that you can control the 4294A. Figure 12-4 shows an example (in which the IP address 1.10.100.50 is assigned to the 4294A). Type 5025 in the Connection Port field (1 in Figure 12-4) and type either the IP address or the host name of the 4294A in the Host Name field (2 in Figure 12-4).

**Figure 12-4** An example of control using HP VEE

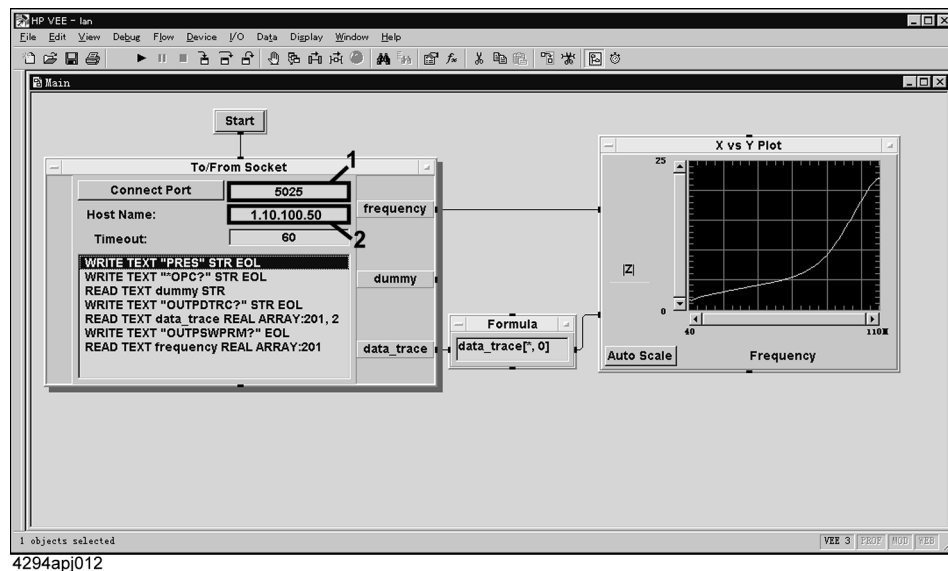

### Control with languages, such as C and Visual Basic

Socket programming allows you to control the 4294A through socket programming from C language in a UNIX environment, or Visual C++ or Visual Basic in a Windows environment. Socket programming requires a library for network connection with TCP/IP protocol. For this purpose, BSD (Berkeley Software Distribution) Sockets API is supplied in the UNIX environment, while WinSock (WinSock 1.1, or WinSock 2.0), prepared by porting BSD Sockets onto Windows and extending it, in the Windows environment.

The sample program disk contains a sample program (ctrl\_lan.bas: Microsoft Excel file) for control with Visual Basic (VBA macro).

First, let us begin with how to use this program. Opening this file will display the screen shown in Figure 12-5. Below are described how to operate each part of this screen.

Figure 12-5

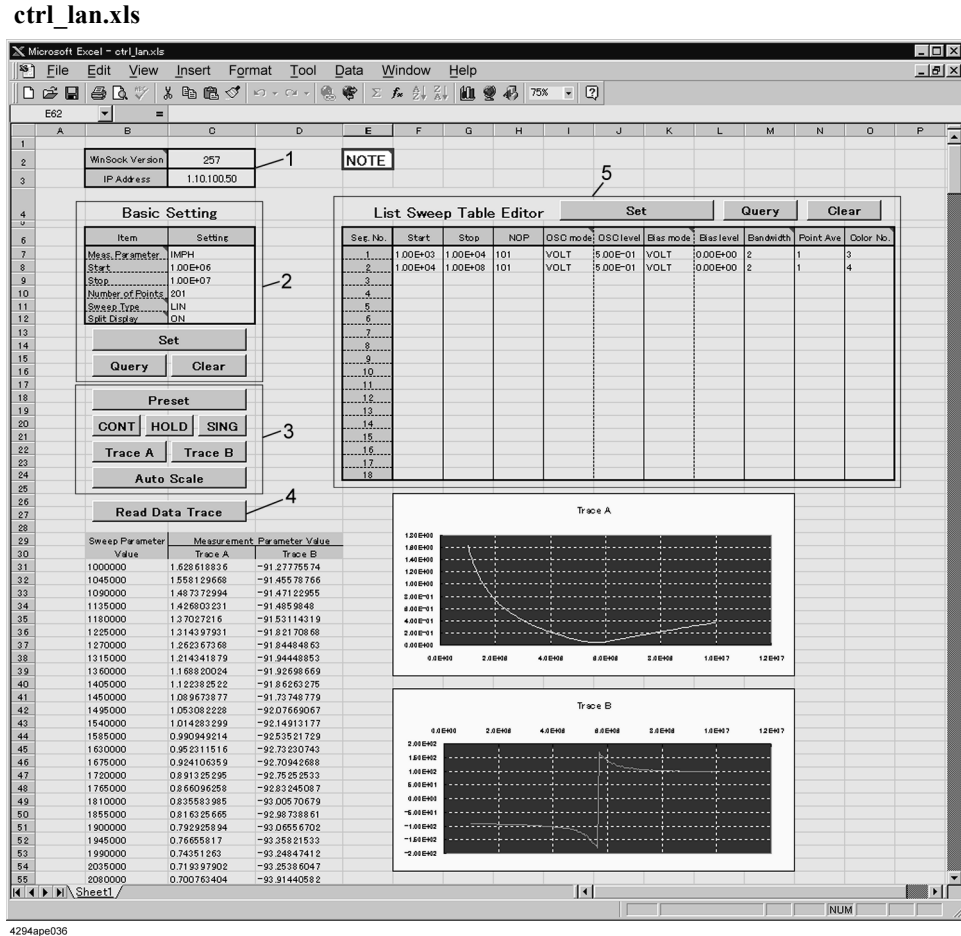

In the part 1, type the version No. of WinSock API into the cell at the right to “WinSock Version.” Determine this version No. by multiplying the major version No. by 256, then adding this product to the minor version No. In the case of Version 1.1, for example,  $256 \times 1 + 1 = 257$ . Type the IP address of the 4294A into the cell at the right to “IP address.” If any of these two entries is wrong, this VBA macro will never work.

In the part 2, set the 4294A’s measurement parameters, the sweep range (starting and stopping points), the number of measurement points, the sweep type, and ON/OFF of trace A/B split display. Clicking the Set button will set these conditions as shown in the Settings Table; clicking the Query button will read the current settings of the 4294A. Clicking the Clear button will clear the Settings Table.

In the part 3, basic control of the 4294A is operated. Below is described what actions each button produces when pressed:

- Preset Returns to the initial setting.
- CONT Sets to continuous sweep.
- HOLD Holds sweep.
- SING Executes sweep once.
- Trace A Sets Trace A to active trace.
- Trace B Sets Trace B to active trace.
- Auto Scale Executes Auto Scale.

## Using LAN

### Controlling the Agilent 4294A

Clicking the Read Data Trace button in the part 4 will read values of data trace to display them in tabular and graphical formats. If the measurement parameter is COMPLEX Z-Y, these table and graph will not be displayed properly.

In the part 5, the List Sweep Table is set. Clicking the Set button will create the List Sweep Table, like the Settings Table; clicking the Query button will read the existing List Sweep Table of the 4294A. Clicking the Clear button will clear the Settings Table. A line on which the Start column has any value will be set in the table even if other columns are blank, and these blank columns will be filled with their initial value.

---

**NOTE**

---

To enable the list sweep, you have to set the sweep type to LIST in the part 2 after setting the List Sweep Table.

Let us move to parts related to control with WinSock API in the VBA macro program.

To use WinSock API, you have to declare functions and define constants in the WinSock API definition file as shown in Example 12-1.

**Example 12-1****WinSock API definition file**

```
'This is the Winsock API definition file for Visual Basic

'Setup the variable type 'hostent' for the WSStartup command
Type Hostent
    h_name As Long
    h_aliases As Long
    h_addrtype As String * 2
    h_length As String * 2
    h_addr_list As Long
End Type
Public Const SZHOSTENT = 16

'Set the Internet address type to a long integer (32-bit)
Type in_addr
    s_addr As Long
End Type

'A note to those familiar with the C header file for Winsock
'Visual Basic does not permit a user-defined variable type
'to be used as a return structure. In the case of the
'variable definition below, sin_addr must
'be declared as a long integer rather than the user-defined
'variable type of in_addr.
Type sockaddr_in
    sin_family As Integer
    sin_port As Integer
    sin_addr As Long
    sin_zero As String * 8
End Type

Public Const WSADESCRIPTION_LEN = 256
Public Const WSASYS_STATUS_LEN = 128
Public Const WSA_DescriptionSize = WSADESCRIPTION_LEN + 1
Public Const WSA_SysStatusSize = WSASYS_STATUS_LEN + 1

'Setup the structure for the information returned from
'the WSStartup() function.
Type WSADATA
    wVersion As Integer
```

```

wHighVersion As Integer
szDescription As String * WSA_DescriptionSize
szSystemStatus As String * WSA_SysStatusSize
iMaxSockets As Integer
iMaxUdpDg As Integer
lpVendorInfo As String * 200
End Type

'Define socket return codes
Public Const INVALID_SOCKET = &HFFFF
Public Const SOCKET_ERROR = -1

'Define socket types
Public Const SOCK_STREAM = 1           'Stream socket
Public Const SOCK_DGRAM = 2           'Datagram socket
Public Const SOCK_RAW = 3              'Raw data socket
Public Const SOCK_RDM = 4              'Reliable Delivery socket
Public Const SOCK_SEQPACKET = 5       'Sequenced Packet socket

'Define address families
Public Const AF_UNSPEC = 0              'unspecified
Public Const AF_UNIX = 1               'local to host (pipes, portals)
Public Const AF_INET = 2               'internetwork: UDP, TCP, etc.
Public Const AF_IMPLINK = 3            'arpanet imp addresses
Public Const AF_PUP = 4                'pup protocols: e.g. BSP
Public Const AF_CHAOS = 5              'mit CHAOS protocols
Public Const AF_NS = 6                 'XEROX NS protocols
Public Const AF_ISO = 7                'ISO protocols
Public Const AF_OSI = AF_ISO            'OSI is ISO
Public Const AF_ECMA = 8               'european computer manufacturers
Public Const AF_DATAKIT = 9            'datakit protocols
Public Const AF_CCITT = 10             'CCITT protocols, X.25 etc
Public Const AF_SNA = 11                'IBM SNA
Public Const AF_DECnet = 12            'DECnet
Public Const AF_DLI = 13                'Direct data link interface
Public Const AF_LAT = 14                'LAT
Public Const AF_HYLINK = 15            'NSC Hyperchannel
Public Const AF_APPLETALK = 16         'AppleTalk
Public Const AF_NETBIOS = 17           'NetBios-style addresses
Public Const AF_MAX = 18                'Maximum # of address families

'Setup sockaddr data type to store Internet addresses
Type sockaddr
  sa_family As Integer
  sa_data As String * 14
End Type
Public Const SADDRLen = 16

'Declare Socket functions

Public Declare Function closesocket Lib "wsock32.dll" (ByVal s As Long)
As Long

Public Declare Function connect Lib "wsock32.dll" (ByVal s As Long, addr
As sockaddr_in, ByVal namelen As Long) As Long

Public Declare Function htons Lib "wsock32.dll" (ByVal hostshort As Long)
As Integer

Public Declare Function inet_addr Lib "wsock32.dll" (ByVal cp As String)
As Long

```

## Using LAN Controlling the Agilent 4294A

```
Public Declare Function recv Lib "wsock32.dll" (ByVal s As Long, ByVal  
buf As Any, ByVal buflen As Long, ByVal flags As Long) As Long  
  
Public Declare Function recvB Lib "wsock32.dll" Alias "recv" (ByVal s As  
Long, buf As Any, ByVal buflen As Long, ByVal flags As Long) As Long  
  
Public Declare Function send Lib "wsock32.dll" (ByVal s As Long, buf As  
Any, ByVal buflen As Long, ByVal flags As Long) As Long  
  
Public Declare Function socket Lib "wsock32.dll" (ByVal af As Long, ByVal  
socktype As Long, ByVal protocol As Long) As Long  
  
Public Declare Function WSASStartup Lib "wsock32.dll" (ByVal  
wVersionRequired As Long, lpWSAData As WSAData) As Long  
  
Public Declare Function WSACleanup Lib "wsock32.dll" () As Long  
  
Public Declare Function WSAUnhookBlockingHook Lib "wsock32.dll" () As  
Long  
  
Public Declare Sub CopyMemory Lib "kernel32" Alias "RtlMoveMemory"  
(hpvDest As Any, hpvSource As Any, ByVal cbCopy As Long)
```

The basic flow of control with WinSock API is as shown in Figure 12-6:

**Figure 12-6** Flow of control with WinSock API

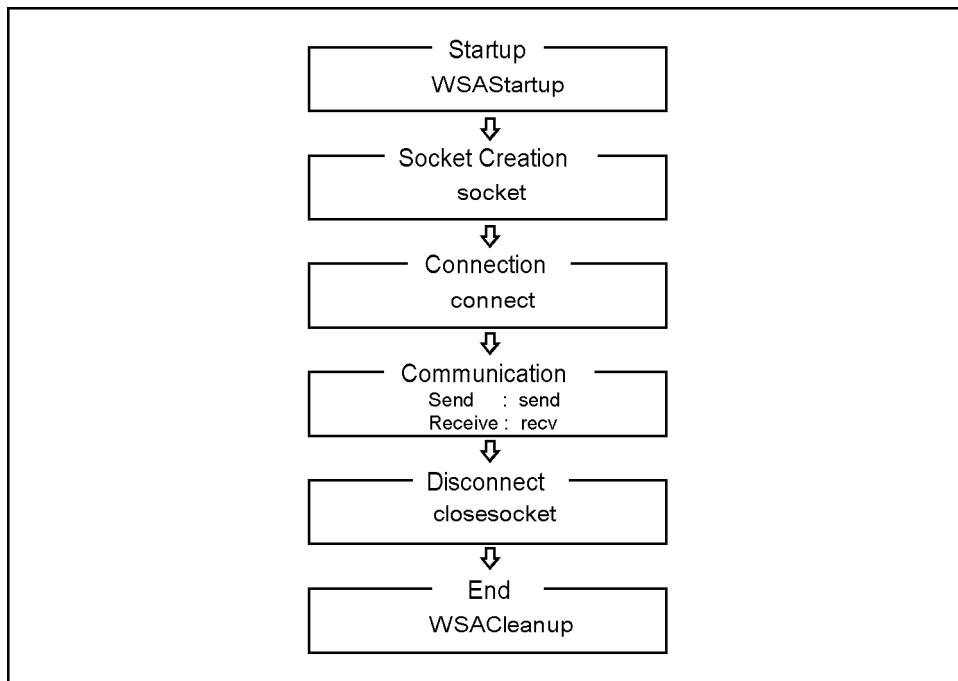

4294ape035



Below are described subprograms corresponding to each step in Figure 12-6:

### Startup

The subprogram corresponding to Startup is StartIt (Example 12-2). StartIt uses the version of WinSock API entered into the part 1 of Figure 12-5 to start up and initialize WinSock API with the WSASStartup function of WinSock API. This WSASStartup function must always be executed at the start of WinSock. Parameters for this function are version No. (input) and startup information (output).

#### Example 12-2

### StartIt

```
Sub StartIt ()

    Dim StartUpInfo As WSADATA

    'Version 1.1 (1*256 + 1) = 257
    'version 2.0 (2*256 + 0) = 512

    'Get WinSock version
    Sheets("Sheet1").Select
    Range("C2").Select
    version = ActiveCell.FormulaR1C1

    'Initialize Winsock DLL
    x = WSASStartup(version, StartUpInfo)

End Sub
```

### Socket creation and connection

The subprogram corresponding to socket creation and connection is OpenSocket (Example 12-3). OpenSocket establishes a connection to the socket of the port specified by PortNumber, an input parameter, on a machine with the IP address specified by Hostname, an input parameter. Below are described steps of OpenSocket:

In (1), the inet\_addr function of WinSock API is used to convert an IP address delimited by “.” to an Internet address.

In (2), the socket function of WinSock API is used to create a new socket and acquire the descriptor of this socket. If an error occurs during this operation, the function outputs a message and returns processing to the main program. Parameters for the socket function are Address Family (input), Socket Type (input) and Protocol No. (input).

In (3), a socket address is set. htons used at setting of the port No. is a WinSock API function that converts a 2-byte integer from the Windows-type byte order (little endian) to the network byte order (big endian).

In (4), the connect function of WinSock is used for connection to the 4294A. If an error occurs during this operation, the function outputs a message and returns processing to the main program. Parameters for the connect function are Socket Descriptor (input), Socket Address and Socket Address Size (input).

#### Example 12-3

### OpenSocket

```
Function OpenSocket(ByVal Hostname As String, ByVal PortNumber As Integer) As Integer

    Dim I_SocketAddress As sockaddr_in
    Dim ipAddress As Long

    ipAddress = inet_addr(Hostname)

    'Create a new socket
    socketId = socket(AF_INET, SOCK_STREAM, 0)
    If socketId = SOCKET_ERROR Then
```

## Using LAN

### Controlling the Agilent 4294A

```

        MsgBox ("ERROR: socket = " + Str$(socketId))           ' ..... (2)
        OpenSocket = COMMAND_ERROR
        Exit Function
    End If

    'Open a connection to a server

    I_SocketAddress.sin_family = AF_INET
    I_SocketAddress.sin_port = htons(PortNumber)             ' ..... (3)
    I_SocketAddress.sin_addr = ipAddress
    I_SocketAddress.sin_zero = String$(8, 0)

    x = connect(socketId, I_SocketAddress, Len(I_SocketAddress))
    If socketId = SOCKET_ERROR Then
        MsgBox ("ERROR: connect = " + Str$(x))               ' ..... (4)
        OpenSocket = COMMAND_ERROR
        Exit Function
    End If

    OpenSocket = socketId

End Function

```

#### Communication

The subprogram corresponding to transmit in communication is SendCommand (Example 12-4). SendCommand uses the send function of WinSock API to transmit a message (GPIB command) specified by command, an input parameter, to the 4294A. Parameters for the send function are Socket Descriptor (input), Transmit Message (input), Message Length (input) and Flag (input).

#### Example 12-4

#### SendCommand

```

Function SendCommand(ByVal command As String) As Integer

    Dim strSend As String

    strSend = command + vbCrLf

    count = send(socketId, ByVal strSend, Len(strSend), 0)

    If count = SOCKET_ERROR Then
        MsgBox ("ERROR: send = " + Str$(count))
        SendCommand = COMMAND_ERROR
        Exit Function
    End If

    SendCommand = NO_ERROR

End Function

```

Subprograms corresponding to receive in communication are RecvAscii (Example 12-5) and others. RecvAscii receives a message in the ASCII format, and store it dataBuf, an output parameter. The maximum length of a message it receives is specified through maxLength, an input parameter. Below are described steps of RecvAscii:

In (1), the recv function of WinSock API is used to receive a message (response to Query, an GPIB command) on a character-by-character basis. If an error occurs during this operation, the function outputs a message and returns processing to the main program. Parameters for the recv function are Socket Descriptor (input), Receipt Message (output), Message Length (input), and Flag (input).

In (2), whether a received character is LF (ASCII code No.: 10) is determined, and if LF, NULL (ASCII code No.: 0) is added to the tail of the character string dataBuf, receipt is ended, and processing returns to the main program.

In (3), the number of characters read immediately before is added to the count for checking the number of received characters, and characters read are added to the tail of the character string dataBuf.

**Example 12-5**

**RecvAscii**

```
Function RecvAscii(dataBuf As String, ByVal maxLength As Integer) As Integer

    Dim c As String * 1
    Dim length As Integer

    dataBuf = ""
    While length < maxLength
        DoEvents
        count = recv(socketId, c, 1, 0)
        If count < 1 Then
            RecvAscii = RECV_ERROR
            dataBuf = Chr$(0)
            Exit Function
        End If

        If c = Chr$(10) Then
            dataBuf = dataBuf + Chr$(0)
            RecvAscii = NO_ERROR
            Exit Function
        End If

        length = length + count
        dataBuf = dataBuf + c
    Wend

    RecvAscii = RECV_ERROR

End Function
```

**Disconnection**

The subprogram corresponding to disconnection is CloseConnection (Example 12-6). CloseConnection uses the closesocket function of WinSock API to disconnect communication, and deletes the socket. The parameter for the closesocket function is Socket Descriptor (input).

**Example 12-6**

**CloseConnection**

```
Sub CloseConnection()

    x = closesocket(socketId)

    If x = SOCKET_ERROR Then
        MsgBox ("ERROR: closesocket = " + Str$(x))
        Exit Sub
    End If

End Sub
```

**End**

The subprogram corresponding to end is EndIt (Example 12-7). EndIt uses the WSACleanup of WinSock API to disconnect WinSock API. WSACleanup must always be executed at the end of WinSock.

**Example 12-7**

**EndIt**

```
Sub EndIt()

    'Shutdown Winsock DLL
    x = WSACleanup()

End Sub
```

## Using LAN

### Controlling the Agilent 4294A

#### Example of control

Like autoscale (subprogram executed when the Auto Scale button is pressed) shown in Example 12-8, executing subprograms above in the sequence above will allow you to control the 4294A.

#### Example 12-8

#### autoscale

```
Sub autoscale()  
'  
' auto scaling  
'  
    Call StartIt  
    Call get_hostname  
    x = OpenSocket(Hostname$, ScpiPort)  
  
    x = SendCommand("AUTO")  
  
    Call CloseConnection  
    Call EndIt  
  
End Sub
```

---

#### NOTE

When you execute more than one command by connecting and disconnecting a socket for every command, the sequence of execution may change.

- Connection → Command 1 → Command 2 → Disconnection  
Commands 1 and 2 are always executed in this sequence.
- Connection → Command 1 → Disconnection → Connection → Command 2 → Disconnection

These commands may be in the sequence of Command 2 → command 1.

---

### Control by making use of the dynamic data disk

You can achieve control from a program via LAN by combining Instrument BASIC programs and file transfers by use of the dynamic data disk. The procedure is given below.

- Step 1.** Transfer an Instrument BASIC program you want run to the dynamic data disk from an external controller under the name prog\_run.bas.
- Step 2.** After having quit the program, transfer necessary measurement data (data\_dt.dat and the like) to the external controller from the dynamic data disk.

---

#### NOTE

Either in an instance in which you need to work on a measurement result by use of a certain program or in an instance in which you need to obtain a result (a result of limit test, or the like) that cannot be transferred directly from the dynamic data disk, write a program in such a way that it once stores necessary data in a file held on the storage devices of the 4294A, and transfer that file to the external controller after the program quits.

---

---

## 13 Application Sample Programs

This chapter provides sample measurements (sample programs).

---

## Basic Measurement

Example 13-1 shows a sample program of a basic capacitor measurement. This program is stored on the sample program disk as the `bsc_meas.bas` file.

This program performs the same measurement described in “Learning basic operations” of the *Agilent 4249A Operation Manual*. Connect the Agilent 16047E test fixture for lead parts to the Agilent 4294A, and then start the program. When “Set Open-Connection” appears, make the connection to measure data for open compensation, and press the **[y]** key and the **[Enter]** key. Then, when “Set Short-Connection” appears, perform the same operation to measure data for short compensation.

---

### NOTE

For how to use the 16047E, for example, the connection to measure data for open/short compensation, refer to its manual.

Then, when “Set DUT, then Push [Enter] key” appears, mount an already discharged capacitor onto the test fixture, and then press the **[Enter]** key. After the completion of a single sweep, the self-resonant point is searched for using the marker, and the frequency and the impedance at that point are displayed. After the display, “Once more? [Y]es/[N]o” appears. If you want to measure the capacitor again or another DUT, press the **[y]** key and the **[Enter]** key to continue the measurement. If you want to finish the measurement, press a key other than the **[y]** key and the **[Enter]** key. Figure 13-1 shows an example when executing this program using Instrument BASIC.

- |                  |  |
|------------------|--|
| Lines 80 to 140  | Identifies the external controller and Instrument BASIC and sets the GPIB address and the select code.   |
| Lines 160 to 250 | Substitutes the measurement conditions (adapter setting: NONE, measurement parameter: $ Z -\theta$ , sweep parameter: frequency, sweep type: LOG, sweep start value: 100 Hz, sweep stop value: 100 MHz, bandwidth setting: 2, trace A display format: logarithmic Y axis, trace B display format: linear Y axis, trace A/B split display: on) into the variables: Adapter\$, Meas_para\$, Swp_para\$, Swp_type\$, Start, Stop, Bw\$, Fmt_a\$, Fmt_b\$, and Spl_disp\$, respectively. |
| Lines 290 to 300 | Sets the adapter selection to Adapter\$ and then triggers a reset.   |
| Lines 310 to 360 | Sets the measurement parameter to Meas_para\$; the sweep parameter, Swp_para\$; the sweep type, Swp_type\$; the sweep start point, Start; the sweep stop point, Stop; the bandwidth, Bw\$, respectively.   |
| Lines 400 to 410 | Enables bit 8 (calibration/compensation data measurement completion) in the instrument event status register to use an SRQ and sets bit 2 in the service request enable register to 1.   |
| Lines 420 to 450 | Uses the FNFixt_comp subprogram to measure open/short data. If an error is detected after each measurement, stops the program. For the FNFixt_comp subprogram, refer to the description in Example 4-3 on page 65.   |
| Lines 490 to 530 | Sets the trace A display format to Fmt_a\$; the trace B display format, Fmt_b\$; the trace A/B split display, Spl_disp\$, respectively.  |
| Lines 570 to 580 | Prompts the user to connect a DUT, and waits for a press of the <b>[Enter]</b> key after the connection.   |

- Lines 600 to 630 Performs a single sweep and waits for its completion.
- Lines 670 to 700 Executes the auto scale on trace A and trace B to automatically set the scale parameters so that waveforms fit on the screen.
- Lines 740 to 760 Searches for the minimum value (self-resonant point) on trace A using the marker.
- Lines 780 to 860 Reads out the measurement parameter value (impedance) and the sweep parameter value (frequency) at the marker on trace A and displays them.
- Lines 880 to 890 Prompts the user to determine whether to perform a measurement again. If the **[y]** key and the **[Enter]** key are pressed, returns to the DUT connection part (line 570).

### Example 13-1

### Measuring the self-resonant point of a capacitor

```

10   DIM Adapter$(9),Meas_para$(5),Swp_para$(9),Swp_type$(9)
20   DIM Bw$(9),Fmt_a$(9),Fmt_b$(9),Spl_disp$(9)
30   DIM Buff$(9),Inp_char$(9)
40   REAL Start,Stop,Imp_val,Freq_val
50   INTEGER Scode,Result
60   CLEAR SCREEN
70   !
80   IF SYSTEM$("SYSTEM ID")="HP4294A" THEN
90     ASSIGN @Hp4294a TO 800
100    Scode=8
110   ELSE
120    ASSIGN @Hp4294a TO 717
130    Scode=7
140   END IF
150   !
160   Adapter$="OFF"
170   Meas_para$="IMPH"
180   Swp_para$="FREQ"
190   Swp_type$="LOG"
200   Start=100
210   Stop=1.0E+8
220   Bw$="2"
230   Fmt_a$="LOGY"
240   Fmt_b$="LINY"
250   Spl_disp$="ON"
260   !
270   ! Measurement Setting
280   !
290   OUTPUT @Hp4294a;"E4TP "&Adapter$
300   OUTPUT @Hp4294a;"PRES"
310   OUTPUT @Hp4294a;"MEAS "&Meas_para$
320   OUTPUT @Hp4294a;"SWPP "&Swp_para$
330   OUTPUT @Hp4294a;"SWPT "&Swp_type$
340   OUTPUT @Hp4294a;"STAR ";Start
350   OUTPUT @Hp4294a;"STOP ";Stop
360   OUTPUT @Hp4294a;"BWFACT "&Bw$
370   !
380   ! Fixture Compensation (Open/Short)
390   !
400   OUTPUT @Hp4294a;"ESNB 256"
410   OUTPUT @Hp4294a;"*SRE 4"
420   Result=FNFixt_comp(@Hp4294a,Scode,"Open")
430   IF Result<>0 THEN Prog_end
440   Result=FNFixt_comp(@Hp4294a,Scode,"Short")
450   IF Result<>0 THEN Prog_end

```

## Application Sample Programs

### Basic Measurement

```
460      !
470      ! Display Setting
480      !
490      OUTPUT @Hp4294a;"TRAC A"
500      OUTPUT @Hp4294a;"FMT "&Fmt_a$
510      OUTPUT @Hp4294a;"TRAC B"
520      OUTPUT @Hp4294a;"FMT "&Fmt_b$
530      OUTPUT @Hp4294a;"SPLD "&Spl_disp$
540      !
550 Meas_start: ! Single Sweep Start
560      !
570      PRINT "Set DUT, then Push [Enter] key"
580      INPUT "",Inp_char$
590      !
600      OUTPUT @Hp4294a;"SING"
610      PRINT "Now measuring..."
620      OUTPUT @Hp4294a;"*OPC?"
630      ENTER @Hp4294a;Buff$
640      !
650      ! Auto Scaling
660      !
670      OUTPUT @Hp4294a;"TRAC A"
680      OUTPUT @Hp4294a;"AUTO"
690      OUTPUT @Hp4294a;"TRAC B"
700      OUTPUT @Hp4294a;"AUTO"
710      !
720      ! Minimum Point Search
730      !
740      OUTPUT @Hp4294a;"TRAC A"
750      OUTPUT @Hp4294a;"MKR ON"
760      OUTPUT @Hp4294a;"SEAM MIN"
770      !
780      OUTPUT @Hp4294a;"MKRVAL?"
790      ENTER @Hp4294a;Imp_val
800      OUTPUT @Hp4294a;"MKRPRM?"
810      ENTER @Hp4294a;Freq_val
820      !
830      PRINT "  ## Measurement Result ##"
840      PRINT USING "13A,4D.4D,6A";"  Frequency: ",Freq_val/1.E+6," [MHz]"
850      PRINT USING "13A,4D.4D,6A";"  Impedance: ",Imp_val," [ohm]"
860      PRINT ""
870      !
880      INPUT "Once more? [Y]es/[N]o",Inp_char$
890      IF UPC$(Inp_char$)="Y" OR UPC$(Inp_char$)="YES" THEN Meas_start
900 Prog_end: !
910      END
920      !
930      ! Fixture Compensation Data Measurement Function
940      !
950 DEF FNFixt_comp(@Hp4294a,INTEGER Scode,Standard$)
960 DIM Inp_char$(9),Err_mes$(50)
970 INTEGER Err_no
980 OUTPUT @Hp4294a;"*CLS"
990 PRINT "Set "&Standard$&"-Connection"
1000 INPUT "OK? [Y/N]",Inp_char$
1010 IF UPC$(Inp_char$)="Y" THEN
1020     ON INTR Scode GOTO Meas_end
1030     ENABLE INTR Scode;2
1040     SELECT Standard$
1050         CASE "Open"
1060             OUTPUT @Hp4294a;"COMA"
1070         CASE "Short"
1080             OUTPUT @Hp4294a;"COMB"
1090         CASE "Load"
```



```

1100         OUTPUT @Hp4294a;"COMC"
1110         END SELECT
1120         PRINT "Now measuring..."
1130 Meas_wait: GOTO Meas_wait
1140 Meas_end: !
1150         PRINT Standard$&" Data Measurement Complete"
1160         RETURN 0
1170     ELSE
1180         PRINT "Program Interruption"
1190         RETURN -1
1200     END IF
1210 FNEND

```

Figure 13-1

An example of the execution result of the program in Example 13-1 (when executed using IBASIC)

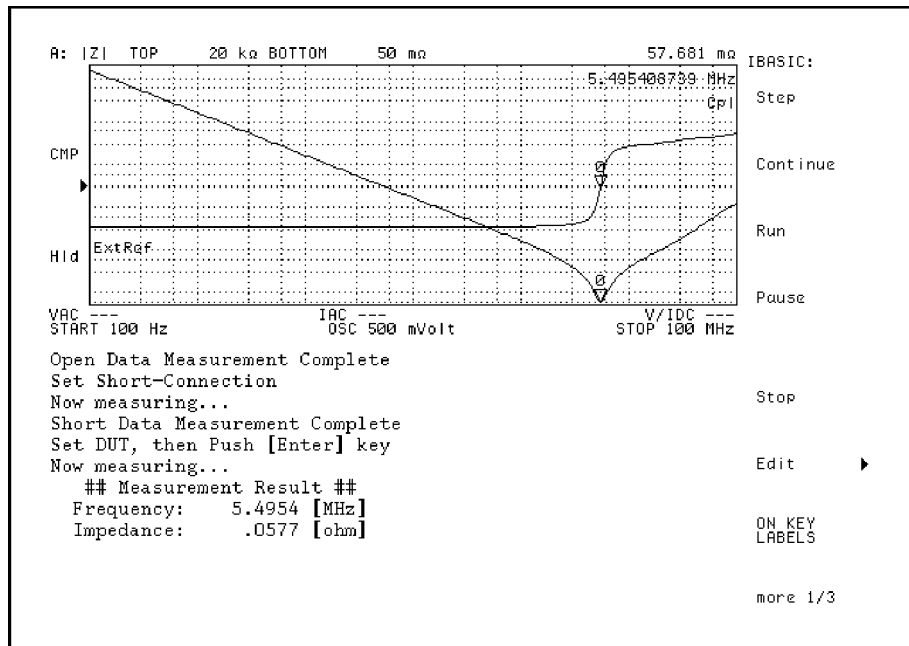

## Measuring Dielectric Material

This section describes how to measure dielectric material using the 4294A and the 16451B dielectric test fixture.

### Measurement Procedure

Figure 13-2 shows the flow of dielectric measurement.

Figure 13-2

#### Flow of Dielectric Measurement

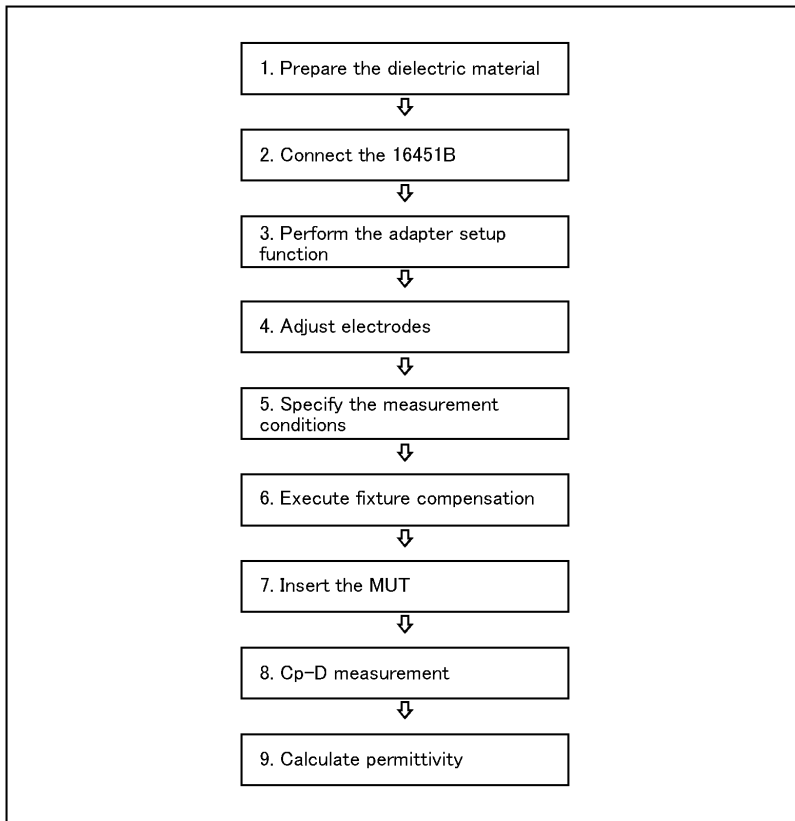

4294ape037

#### Step 1. Prepare the dielectric material

Fabricate the MUT to the appropriate size. If the contacting electrode method with thin film electrodes is employed, apply thin film electrodes to the surfaces of the MUT.

#### NOTE

For details on how to handle the 16451B (the shape of material suitable for measurement, how to adjust the electrodes to be parallel, and so on), refer to the 16451B Operation and Service Manual.

#### Step 2. Connect the 16451B

Mount appropriate electrodes onto the 16451B and connect the 16451B to the UNKNOWN terminals of the 4294A.

**Step 3.** Perform the adapter setup function

Select 4TP 1M as the adapter, measure the phase data for calculating the setup data, calculate the setup data, and store it into the nonvolatile memory.

**NOTE**

For details on how to set up the adapter when connecting the 16451B, refer to “Preparing Accessories for Measurement” in the 4294A Operation Manual.

**Step 4.** Adjust the electrodes

To enhance the measurement performance, a mechanism is provided to adjust the guarded and unguarded electrodes to be parallel to each other. By performing this adjustment, the occurrence of the airgap when using the contacting electrode method is minimized and an airgap with uniform thickness is created when using the non-contacting electrode method. The adjustment procedure is discussed in the operation manual of the 16451B.

**Step 5.** Specify the measurement conditions

Specify the measurement conditions including the measurement frequency and the measurement signal level.

**Step 6.** Execute fixture compensation

Execute OPEN/SHORT compensation to compensate the residual impedance of the 16451B. Measure OPEN/SHORT compensation data using the furnished attachment that comes with the 16451B to make OPEN/SHORT condition.

If the measurement frequency exceeds 5 MHz, you must perform LOAD compensation in addition to OPEN/SHORT compensation. Use an air capacitor (adjust the distance between the electrodes to obtain the value in the following table) as the standard when measuring the LOAD compensation data. As the standard value for LOAD compensation, use the equivalent parallel capacitance value ( $C_p$ ) measured at a low frequency (100 kHz). (It is assumed that the air capacitor has no dependence on frequency.)

Electrodes	Value of Load (Air Capacitor)
A	50 pF $\pm$ 0.5 pF
B	5 pF $\pm$ 0.05 pF
C and D	1.5 pF $\pm$ 0.05 pF

**NOTE**

The 4294A does not allow you to define the LOAD standard using the values  $C_p$  and  $G$ . Therefore, you must use the OPEN standard and the LOAD standard inversely. To be more specific, first, define the OPEN standard value as the LOAD standard and the LOAD standard value as the OPEN standard, and then use the connection for LOAD measurement when executing the OPEN measurement command and use the connection for OPEN measurement when executing the LOAD measurement command. For details, refer to the 4294A Operation Manual.

Actual measurement procedure for the LOAD standard (OPEN compensation data) is as follows: Adjust the distance between the 16451B’s electrodes, measure  $C_p$  at 100 kHz, and sets it as the OPEN compensation standard value ( $C_p$ : measured value and  $G$ : 0). Then, by maintaining the distance between the electrodes, measure data as the OPEN compensation data at the frequency points where you want to measure the material (execute the OPEN compensation data measurement command).

Application Sample Programs  
**Measuring Dielectric Material**

**Step 7.** Insert the MUT

Insert the MUT between the 16451B's electrodes.

**Step 8.** Cp-D measurement

Measure the equivalent parallel capacitance ( $C_p$ ) and the dissipation factor ( $D$ ). When using the non-contacting electrode method, perform the Cp-D measurement twice in this step: one with the MUT connected and the other not connected.

**Step 9.** Calculate permittivity

Using the following expressions and the result of the impedance measurement, calculate the complex relative permittivity ( $\epsilon_r = \epsilon_r' - j\epsilon_r''$ ) and the dielectric dissipation factor ( $D_t$ ) of the MUT.

**Equation 13-1**

**Expressions to calculate the complex relative permittivity (each term) and the dielectric dissipation factor when using the contacting electrode method**

$$\epsilon_r' = \frac{t_a \times C_p}{\pi \times (d/2)^2 \times \epsilon_0} \quad \epsilon_r'' = \frac{\epsilon_r'}{D_t}$$

$$D_t = D$$

**Equation 13-2**

**Expressions to calculate the complex relative permittivity (each term) and the dielectric dissipation factor when using the non-contacting electrode method**

$$\epsilon_r' = \frac{1}{1 - \left(1 - \frac{C_{p1}}{C_{p2}}\right) \times \frac{t_g}{t_a}} \quad \epsilon_r'' = \frac{\epsilon_r'}{D_t}$$

$$D_t = D_2 + \epsilon_r \times (D_2 - D_1) \times \left(\frac{t_g}{t_a} - 1\right)$$

Where,

$\epsilon_0$	Permittivity of vacuum (=8.854×10 <sup>-12</sup> ) [F/m]
$C_p$	Measured equivalent parallel capacitance value [F] (contacting electrode method)
$C_{p1}$	Measured equivalent parallel capacitance value when no MUT is inserted [F] (non-contacting electrode method)
$C_{p2}$	Measured equivalent parallel capacitance value when an MUT is inserted [F] (non-contacting electrode method)
$D$	Measured dissipation factor value (contacting electrode method)
$D_1$	Measured dissipation factor value when no MUT is inserted (non-contacting electrode method)
$D_2$	Measured dissipation factor value when an MUT is inserted (non-contacting electrode method)
$t_a$	Thickness of MUT [m]
$t_g$	Distance between the guarded and unguarded electrodes [m]
$d$	Electrode diameter [m]
$\pi$	Pi (circular constant)

### Sample Program for Contacting Electrode Method

Example 13-2 shows a sample program to measure dielectric materials (contacting electrode method) (for HP Instrument BASIC). You can find the source file of this program, named `permi_c.bas`, on the sample program disk.

The steps to use the program are described below:

- Step 1.** Connect the 16451B dielectric test fixture to the 4294A, and start this program. When the message “Which electrode of 16451B is used? 0:A, 1:B, 2:C, 3:D” is displayed, select the electrodes you want to use by specifying the corresponding number (0 to 3).
- Step 2.** When the message “Perform the adapter setup? 0:Yes, 1:Skip” is displayed, enter 0 if you want to set up the adapter.
- Step 3.** When the message "Set the 16451B OPEN condition and press 'Continue'." is displayed, bring the 16451B into OPEN condition and press the **Continue** key (2nd softkey from the top). The phase data for calculating the setup data will be measured.
- Step 4.** When the message “Set the micrometer of 16451B at 10um and press 'Continue'.” is displayed, turn the small knob of micrometer and adjust it until the micrometer indicates 10  $\mu\text{m}$  and press the **Continue** key. (Steps 4 and 5 are required only when the electrodes you use are A or B.)
- Step 5.** When the message “Adjust the electrode until PASS is displayed” is displayed, turn the three adjustment screw (under the unguarded electrode) to adjust the electrodes to be parallel until the limit test results display PASS, and press the **Continue** key.
- Step 6.** When the message “Start frequency [Hz] = ?” is displayed, enter the frequency at the sweep start point. In the same way, enter the frequency at the sweep stop point, the sweep type, the signal source level, and the number of measurement points. When you have completed all entries, they are displayed followed by the message “Measurement condition is OK? 0:OK, 1:NO”. If you find no mistake, enter 0.
- Step 7.** When the message “Turn the micrometer's knob until PASS is displayed.” is displayed, turn the 16451B’s knob to adjust the distance between the electrodes until the limit test results display PASS (so that the air capacitor used as the LOAD standard becomes an appropriate value), and press the **Continue** key.
- Step 8.** When the message “Set the 16451B OPEN condition and press 'Continue'." is displayed, bring the 16451B into OPEN condition and press the **Continue** key.
- Step 9.** When the message “Set the 16451B SHORT condition and press 'Continue'." is displayed, bring the 16451B into SHORT condition and press the **Continue** key.
- Step 10.** When the message “Thickness of MUT [mm] = ?” is displayed, enter the thickness of the dielectric material (MUT) you want to measure. If you use electrode C or D, when the next message “Diameter of electrode [mm] = ?” is displayed, enter the electrode diameter.
- Step 11.** When the message “Set MUT between the electrodes and press 'Continue'." is displayed, insert the MUT between the electrodes and press the **Continue** key to measure the equivalent parallel capacitance ( $C_p$ ) and the dissipation factor ( $D$ ).
- Step 12.** When the message “Select softkey to display each parameter.” is displayed, press the softkey for the parameter you want to display on the screen. Figure 13-5 shows an example of the screen display when selecting the real part of the complex relative permittivity ( $\epsilon_r'$ ) and the dielectric dissipation factor as displayed parameters. At this time, pressing the “Quit” softkey terminates the program and pressing the “Re-measure” softkey lets you repeat the procedure from Step 10.

Figure 13-3

Example of the Result of Executing the Program of Example 13-2

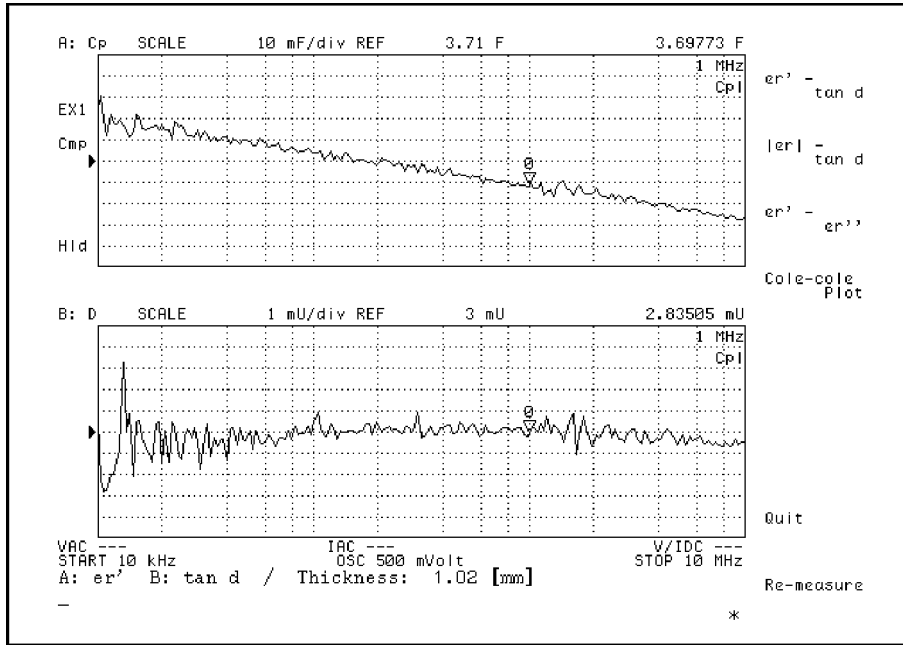

4294apj039

The program is described in detail below:

- Line 80                Sets the GPIB address.
- Lines 90 to 100     Assigns the upper half of the LCD screen to measurement result display and the lower half to the HP Instrument BASIC, and terminates the sweep.
- Line 130             Stores the permittivity of vacuum into the E0 variable.
- Lines 140 to 180    Stores the conditions to adjust the electrodes into variables.
- Lines 190 to 210    Stores the measurement conditions to evaluate the capacitance of the LOAD standard into variables.
- Lines 220 to 290    Stores the limit range of the air capacitor, used as the LOAD standard, into variables.
- Lines 300 to 340    Stores the OPEN standard values (resistance value: 100 GΩ, inductance value: 0 H), the SHORT standard values (resistance value: 0 Ω, inductance value: 0 H), and the LOAD standard values (conductance value: 0 S) into the Open\_r, Open\_l, Short\_r, Short\_l, and Load\_g variables, respectively.
- Lines 350 to 370    Stores the band width setting and the diameters of electrodes A and B into variables.
- Lines 400 to 490    Displays the message at the start of the program.
- Line 520             Passes control to a subroutine named Select\_elec to select the electrodes to be used.
- Line 530             Passes control to a subroutine named Adapter\_setup to set up the adapter.
- Line 540             Passes control to a subroutine named Adjust to adjust the electrodes to

- be parallel.
- Line 550 Passes control to a subroutine named Compen to execute fixture compensation.
- Lines 570 to 580 Passes control to subroutines named Input\_t and Input\_d to set the MUT thickness and the electrode diameter.
- Line 590 Passes control to a subroutine named Sweep to perform measurement.
- Line 600 Passes control to a subroutine named Calc to calculate each parameter.
- Line 610 Jumps to the Display line and displays each parameter.
- Lines 640 to 960 The Select\_elec subroutine.
- Lines 660 to 670: Waits until you select the electrodes and enter the selection.
- Lines 680 to 910: According to the electrode selection, sets the limit range of electrode adjustment and the limit range of the air capacitor used as the LOAD standard.
- Lines 920 to 940: Prompts you to confirm the electrode selection.
- Lines 980 to 1170 The Adapter\_setup subroutine.
- Lines 990 to 1040: Asks you if you want to perform adapter setup.
- Lines 1060 to 1090: After reset, waits until you complete the connection for measuring the phase data and press the **Continue** key.
- Lines 1100 to 1140: Sets 4TP 1M as the adapter selection, measures the phase compensation data, calculates the setup data, and saves it into the nonvolatile memory.
- Lines 1190 to 1670 The Adjust subroutine.
- Lines 1200 to 1310: When you use electrode A or B, asks you if you want to execute electrode adjustment.
- Lines 1340 to 1510: Sets up the measurement conditions used when adjusting the electrodes to be parallel.
- Lines 1540 to 1550: Waits until you finish turning the small knob and 16451B's micrometer indicates 10  $\mu\text{m}$  and press the **Continue** key.
- Lines 1560 to 1600: Waits until you adjust the electrodes so that the limit test results display PASS and press the **Continue** key.
- Lines 1610 to 1650: Checks the limit test result.
- Lines 1690 to 2670 The Compen subroutine.
- Lines 1710 to 1760: Asks you if you want to execute fixture compensation.
- Lines 1790 to 1990: Obtains the setting values (the sweep range, the sweep type, the signal source level, and the number of measurement points) from user input.
- Lines 2010 to 2200: Sets the conditions for measurement where an

## Application Sample Programs

### Measuring Dielectric Material

air capacitor is used as the LOAD standard.

Lines 2230 to 2260: Waits until you adjust the distance between the electrodes so that the limit test results display PASS (an appropriate air capacitor value is obtained) and press the **Continue** key.

Lines 2270 to 2300: Checks the limit test result.

Lines 2330 to 2340: Retrieves the measurement result (Cp) and stores it into the Load\_c variable for the LOAD standard value.

Lines 2360 to 2410: Sets up the measurement conditions used when performing fixture compensation.

Lines 2420 to 2470: Defines the values of each OPEN/SHORT/LOAD standard.

---

**NOTE**

In order to define the LOAD standard using the values Cp and G, the OPEN standard and LOAD standard must be defined inversely.

---

Lines 2490 to 2640: Measures the compensation data for each of OPEN/SHORT/LOAD.

---

**NOTE**

Because the OPEN and LOAD standards are defined inversely, the commands for measuring the OPEN and LOAD compensation data are also used inversely.

---

Lines 2690 to 2730 The Input\_t subroutine.

Lines 2750 to 2890 The Input\_d subroutine.

Lines 2270 to 2820: When you use electrode A or B, sets the electrode diameter from the values already set in the variables within the program.

Lines 2830 to 2870: When you use electrode C or D, sets the electrode diameter from user input.

Lines 2910 to 3100 The Sweep subroutine.

Lines 2920 to 2930: Waits until you insert the MUT into the 16451B and press the **Continue** key.

Lines 2940 to 3000: Measures Cp and D.

Lines 3010 to 3090: Retrieves the measurement results and stores them into the Cp\_data and D\_data arrays.

Lines 3120 to 3230 The Calc subroutine. Using the Cp\_data and D\_data arrays, calculates the complex relative permittivity and the dielectric dissipation factor.

Lines 3250 to 3350 Sets the softkey labels and the subroutines to be executed when each key is pressed. Then, waits until you press one of the softkeys.

Lines 3370 to 3580 Processing when the softkey labeled as “er' - tan d” is pressed. Displays the real part of the complex relative permittivity ( $\epsilon_r'$ ) as trace A and the dielectric dissipation factor as trace B.

Lines 3600 to 3810 Processing when the softkey labeled as “|er| - tan d” is pressed. Displays the magnitude of the complex relative permittivity



$(\sqrt{\epsilon_r'^2 + \epsilon_r''^2})$  as trace A and the dielectric dissipation factor as trace B.

Lines 3830 to 4040 Processing when the softkey labeled as “er' - er” is pressed. Displays the real part of the complex relative permittivity ( $\epsilon_r'$ ) as trace A and the imaginary part of the complex relative permittivity ( $\epsilon_r''$ ) as trace B.

Lines 4060 to 4190 Processing when the softkey labeled as “Cole-cole Plot” is pressed. Displays the COLE-COLE plot on the complex plane.

Lines 4210 to 4310 Processing when the softkey labeled as “Re-measure” is pressed.

Lines 4330 to 4430 Processing when the softkey labeled as “Quit” is pressed.

### Example 13-2

### Dielectric (Relative Permittivity) Measurement (Contacting Electrode Method)

```

10  !*****
20  !* 4294A + 16451B Permittivity Measurement (Contact Method)
30  !* Instrument BASIC Sample Program
40  !*****
50  DIM Cp_data(1:801,1:2),D_data(1:801,1:2),Err_data(1:801,1:2)
60  DIM Eri_data(1:801,1:2),Erm_data(1:801,1:2),Cole_data(1:801,1:2)
70  !
80  ASSIGN @Agt4294a TO 800
90  OUTPUT @Agt4294a;"DISA HIHB"
100 OUTPUT @Agt4294a;"HOLD"
110 !
120 Constants:  !
130 E0=8.854E-12
140 Adj_center=100000.
150 Adj_up_limit_a=1.E-9
160 Adj_low_limit_a=7.E-10
170 Adj_up_limit_b=2.E-11
180 Adj_low_limit_b=1.2E-11
190 Load_center=100000.
200 Load_ave=4
210 Load_bw=5
220 Load_up_limit_a=5.05E-11  ! [pF]
230 Load_lo_limit_a=4.95E-11
240 Load_up_limit_b=5.05E-12
250 Load_lo_limit_b=4.95E-12
260 Load_up_limit_c=1.55E-12
270 Load_lo_limit_c=1.45E-12
280 Load_up_limit_d=1.55E-12
290 Load_lo_limit_d=1.45E-12
300 Open_r=1.E+11  ! [ohm]
310 Open_l=0
320 Short_r=0
330 Short_l=0
340 Load_g=0
350 Bw=3
360 D_elec_a=.038  ! [m]
370 D_elec_b=.005
380 !
390 !##### Main
400 Disp_proc:!
410 CLEAR SCREEN
420 PRINT "4294A + 16451B Permittivity Measurement Program"
430 PRINT " (Contact Method Measurement)"
440 PRINT ""

```

## Application Sample Programs

### Measuring Dielectric Material

```
450 PRINT "[ ] Select the main electrode of 16451B"
460 PRINT "[ ] Perform the adapter setup (1m cable)"
470 PRINT "[ ] Adjust the electrodes (Parallelizing)"
480 PRINT "[ ] Perform fixture compensation"
490 PRINT "x: done, s: skip, n: not required."
500 !
510 Adjustment: !
520 GOSUB Select_elec
530 GOSUB Adapter_setup
540 GOSUB Adjust
550 GOSUB Compen
560 Meas: !
570 GOSUB Input_t
580 GOSUB Input_d
590 GOSUB Sweep
600 GOSUB Calc
610 GOTO Display
620 !
630 !##### Sub-routines
640 Select_elec:!
650 PRINT TABXY(5,4);"->"
660 DISP "Which electrode of 16451B is used? 0:A, 1:B, 2:C, 3:D";
670 INPUT "",Ans
680 SELECT Ans
690 CASE 0
700 Elec$="A"
710 Adj_up_limit=Adj_up_limit_a
720 Adj_low_limit=Adj_low_limit_a
730 Load_up_limit=Load_up_limit_a
740 Load_low_limit=Load_lo_limit_a
750 CASE 1
760 Elec$="B"
770 Adj_up_limit=Adj_up_limit_b
780 Adj_low_limit=Adj_low_limit_b
790 Load_up_limit=Load_up_limit_b
800 Load_low_limit=Load_lo_limit_b
810 CASE 2
820 Elec$="C"
830 Load_up_limit=Load_up_limit_c
840 Load_low_limit=Load_lo_limit_c
850 CASE 3
860 Elec$="D"
870 Load_up_limit=Load_up_limit_d
880 Load_low_limit=Load_lo_limit_d
890 CASE ELSE
900 GOTO Select_elec
910 END SELECT
920 DISP "The electrode ";Elec$;" is selected. OK? 0:OK, 1:No";
930 INPUT "",Ans
940 IF Ans<>0 THEN Select_elec
950 PRINT TABXY(2,4);"x] "
960 RETURN
970 !
980 Adapter_setup:!
990 DISP "Perform the adapter setup? 0:Yes, 1:Skip";
1000 INPUT "",Ans
1010 IF Ans=1 THEN
1020 PRINT TABXY(2,5);"s] "
1030 RETURN
1040 END IF
1050 F_adapt_setup=1
1060 OUTPUT @Agt4294a;"PRES"
1070 PRINT TABXY(5,5);"->"
1080 DISP "Set the 16451B OPEN condition and press 'Continue'."
```

```

1090 PAUSE
1100 DISP "Wait until the setup is finished."
1110 OUTPUT @Agt4294a;"E4TP M1;ECALP"
1120 OUTPUT @Agt4294a;"*OPC?"
1130 ENTER @Agt4294a;Opc
1140 OUTPUT @Agt4294a;"ECALDON"
1150 DISP ""
1160 PRINT TABXY(2,5);"x]  "
1170 RETURN
1180 !
1190 Adjust: !
1200 IF Elec$="C" OR Elec$="D" THEN
1210     PRINT TABXY(2,6);"n]  "
1220     RETURN
1230 END IF
1240 IF F_adapt_setup=0 THEN
1250     DISP "Perform the electrode adjustment?      0:Yes, 1:Skip";
1260     INPUT "",Ans
1270     IF Ans=1 THEN
1280         PRINT TABXY(2,6);"s]  "
1290         RETURN
1300     END IF
1310 END IF
1320 F_adjust=1
1330 PRINT TABXY(5,6);"->"
1340 OUTPUT @Agt4294a;"SWPT LIN"
1350 OUTPUT @Agt4294a;"CENT  ";Adj_center
1360 OUTPUT @Agt4294a;"SPAN 0"
1370 OUTPUT @Agt4294a;"POIN 2"
1380 OUTPUT @Agt4294a;"CALP USER"
1390 OUTPUT @Agt4294a;"MEAS CPD;TRAC A"
1400 OUTPUT @Agt4294a;"HIDI ON"
1410 OUTPUT @Agt4294a;"EDITLIML"
1420 OUTPUT @Agt4294a;"LIMCLEL ;LIMSADD"
1430 OUTPUT @Agt4294a;"LIMSTAR ";Adj_center
1440 OUTPUT @Agt4294a;"LIMSTOP ";Adj_center
1450 OUTPUT @Agt4294a;"LIMLSTAR ";Adj_low_limit
1460 OUTPUT @Agt4294a;"LIMUSTAR ";Adj_up_limit
1470 OUTPUT @Agt4294a;"LIMLSTOP ";Adj_low_limit
1480 OUTPUT @Agt4294a;"LIMUSTOP ";Adj_up_limit
1490 OUTPUT @Agt4294a;"LIMSDON;LIMEDONE"
1500 OUTPUT @Agt4294a;"TOPV  ";1.5*Adj_up_limit-.5*Adj_low_limit
1510 OUTPUT @Agt4294a;"BOTV  ";1.5*Adj_low_limit-.5*Adj_up_limit
1520 !
1530 OUTPUT @Agt4294a;"LIMITEST OFF"
1540 DISP "Set the micrometer of 16451B at 10um and press 'Continue'."
1550 PAUSE
1560 OUTPUT @Agt4294a;"LIMITEST ON"
1570 OUTPUT @Agt4294a;"CONT"
1580 OUTPUT @Agt4294a;"MKR ON"
1590 DISP "Adjust the electrode until PASS is displayed"
1600 PAUSE
1610 OUTPUT @Agt4294a;"HOLD"
1620 OUTPUT @Agt4294a;"OUTPFAIP?"
1630 ENTER @Agt4294a;F_nop
1640 IF F_nop<>0 THEN Adj
1650 OUTPUT @Agt4294a;"LIMITEST OFF"
1660 PRINT TABXY(2,6);"x]  "
1670 RETURN
1680 !
1690 Compen: !
1700 IF F_adjust=0 THEN
1710     DISP "Perform the fixture compensation?      0:Yes, 1:Skip";
1720     INPUT "",Ans

```

## Application Sample Programs

### Measuring Dielectric Material

```
1730     IF Ans=1 THEN
1740         PRINT TABXY(2,7);"s]   "
1750         RETURN
1760     END IF
1770 END IF
1780 PRINT TABXY(4,7);"->"
1790 Input_config:!
1800 DISP "Start frequency [Hz] = ?";
1810 INPUT "",Start
1820 DISP "Stop frequency [Hz] = ?";
1830 INPUT "",Stop
1840 DISP "Sweep type?  0:Linear, 1:Log";
1850 INPUT Ans
1860 IF Ans=1 THEN
1870     Swe_type$="LOG"
1880 ELSE
1890     Swe_type$="LIN"
1900 END IF
1910 DISP "OSC level [V] =?";
1920 INPUT "",Vosc
1930 DISP "Number of point?  [2-801]";
1940 INPUT Nop
1950 PRINT TABXY(1,10);"Start: ";Start;"[Hz]  Stop: ";Stop;"[Hz]";" Nop
: ";Nop
1960 PRINT TABXY(1,11);"Sweep Type: ";Swe_type$;"  OSC Level: ";Vosc;"[V
]";
1970 DISP "Measurement condition is OK?          0:OK, 1:NO";
1980 INPUT "",Ans
1990 IF Ans<>0 THEN Input_config
2000 !
2010 OUTPUT @Agt4294a;"CALP USER"
2020 OUTPUT @Agt4294a;"MEAS CPD;TRAC A"
2030 OUTPUT @Agt4294a;"SWPT LIN"
2040 OUTPUT @Agt4294a;"CENT ";Load_center
2050 OUTPUT @Agt4294a;"SPAN 0"
2060 OUTPUT @Agt4294a;"POIN ";2
2070 OUTPUT @Agt4294a;"BWFACT ";Load_bw
2080 OUTPUT @Agt4294a;"PAVER ON;PAVERFACT ";Load_ave
2090 OUTPUT @Agt4294a;"LIMTEST ON;EDITLIML"
2100 OUTPUT @Agt4294a;"LIMCLEL ;LIMSADD"
2110 OUTPUT @Agt4294a;"LIMSTAR ";Load_center
2120 OUTPUT @Agt4294a;"LIMSTOP ";Load_center
2130 OUTPUT @Agt4294a;"LIMLSTAR ";Load_low_limit
2140 OUTPUT @Agt4294a;"LIMUSTAR ";Load_up_limit
2150 OUTPUT @Agt4294a;"LIMLSTOP ";Load_low_limit
2160 OUTPUT @Agt4294a;"LIMUSTOP ";Load_up_limit
2170 OUTPUT @Agt4294a;"LIMSDON;LIMEDONE"
2180 OUTPUT @Agt4294a;"TOPV ";1.5*Load_up_limit-.5*Load_low_limit
2190 OUTPUT @Agt4294a;"BOTV ";1.5*Load_low_limit-.5*Load_up_limit
2200 OUTPUT @Agt4294a;"HIDI ON"
2210 !
2220 Load_adj:!!
2230 OUTPUT @Agt4294a;"CONT"
2240 OUTPUT @Agt4294a;"MKR ON"
2250 DISP "Turn the micrometer's knob until PASS is displayed."
2260 PAUSE
2270 OUTPUT @Agt4294a;"HOLD"
2280 OUTPUT @Agt4294a;"OUTPFAIP?"
2290 ENTER @Agt4294a;F_nop
2300 IF F_nop<>0 THEN Load_adj
2310 DISP ""
2320 OUTPUT @Agt4294a;"LIMTEST OFF"
2330 OUTPUT @Agt4294a;"OUTPDTRCP? 1"
2340 ENTER @Agt4294a;Load_c,Dummy
```

```

2350 !
2360 OUTPUT @Agt4294a;"STAR ";Start
2370 OUTPUT @Agt4294a;"STOP ";Stop
2380 OUTPUT @Agt4294a;"SWPT ";Swe_type$
2390 OUTPUT @Agt4294a;"POIN ";Nop
2400 OUTPUT @Agt4294a;"BWFACT ";Bw
2410 OUTPUT @Agt4294a;"POWMOD VOLT;POWE ";Vosc
2420 OUTPUT @Agt4294a;"DCOMOPENG ";Load_g
2430 OUTPUT @Agt4294a;"DCOMOPENC ";Load_c/1.E-15
2440 OUTPUT @Agt4294a;"DCOMSHORR ";Short_r
2450 OUTPUT @Agt4294a;"DCOMSHORL ";Short_l
2460 OUTPUT @Agt4294a;"DCOMLOADR ";Open_r
2470 OUTPUT @Agt4294a;"DCOMLOADL ";Open_l
2480 !
2490 OUTPUT @Agt4294a;"COMA"
2500 DISP "Now measuring LOAD..."
2510 OUTPUT @Agt4294a;"*OPC?"
2520 ENTER @Agt4294a;Opc
2530 DISP "Set 16451B OPEN condition and press 'Continue'."
2540 PAUSE
2550 OUTPUT @Agt4294a;"COMC"
2560 DISP "Now measuring OPEN..."
2570 OUTPUT @Agt4294a;"*OPC?"
2580 ENTER @Agt4294a;Opc
2590 DISP "Set 16451B SHORT condition and press 'Continue'."
2600 PAUSE
2610 DISP "Now measuring SHORT..."
2620 OUTPUT @Agt4294a;"COMB"
2630 OUTPUT @Agt4294a;"*OPC?"
2640 ENTER @Agt4294a;Opc
2650 DISP ""
2660 PRINT TABXY(2,7);"x]  "
2670 RETURN
2680 !
2690 Input_t:!
2700 DISP "Thickness of MUT [mm] = ?";
2710 INPUT "",Ans
2720 T_dut=Ans/1000
2730 RETURN
2740 !
2750 Input_d:!
2760 SELECT Elec$
2770 CASE "A"
2780   D_elec=D_elec_a
2790   RETURN
2800 CASE "B"
2810   D_elec=D_elec_b
2820   RETURN
2830 CASE ELSE
2840   DISP "Diameter of electrode [mm] = ?";
2850   INPUT "",D_elec
2860   D_elec=D_elec*.001
2870   RETURN
2880 END SELECT
2890 RETURN
2900 !
2910 Sweep: !
2920 DISP "Set MUT between the electrodes and press 'Continue'."
2930 PAUSE
2940 OUTPUT @Agt4294a;"DISA BASS"
2950 OUTPUT @Agt4294a;"MEAS CPD"
2960 OUTPUT @Agt4294a;"HIDI OFF"
2970 OUTPUT @Agt4294a;"SING"
2980 DISP "Now measuring Cp-D..."

```

## Application Sample Programs

### Measuring Dielectric Material

```
2990 OUTPUT @Agt4294a;"*OPC?"
3000 ENTER @Agt4294a;Opc
3010 DISP "Now getting data..."
3020 OUTPUT @Agt4294a;"TRAC A"
3030 OUTPUT @Agt4294a;"AUTO"
3040 OUTPUT @Agt4294a;"OUTPDTRC?"
3050 ENTER @Agt4294a USING "%,K";Cp_data(*)
3060 OUTPUT @Agt4294a;"TRAC B"
3070 OUTPUT @Agt4294a;"AUTO"
3080 OUTPUT @Agt4294a;"OUTPDTRC?"
3090 ENTER @Agt4294a USING "%,K";D_data(*)
3100 RETURN
3110 !
3120 Calc: !
3130 FOR I=1 TO Nop
3140   Err_data(I,1)=(T_dut*Cp_data(I,1))/(PI*E0*(D_elec/2)^2)
3150   Err_data(I,2)=0
3160   Eri_data(I,1)=Err_data(I,1)*D_data(I,1)
3170   Eri_data(I,2)=0
3180   Erm_data(I,1)=SQR(Err_data(I,1)^2+Eri_data(I,1)^2)
3190   Erm_data(I,2)=0
3200   Cole_data(I,1)=Err_data(I,1)
3210   Cole_data(I,2)=Eri_data(I,1)
3220 NEXT I
3230 RETURN
3240 !
3250 Display: !
3260 ON KEY 1 LABEL "er' -          tan d",1 GOSUB Disp_er_d
3270 ON KEY 2 LABEL "|er| -         tan d",1 GOSUB Disp_em_d
3280 ON KEY 3 LABEL "er' -          er'",1 GOSUB Disp_er_ei
3290 ON KEY 4 LABEL "Cole-cole      Plot",1 GOSUB Disp_cole
3300 ON KEY 7 LABEL "Quit",1 GOTO Quit
3310 ON KEY 8 LABEL "Re-measure",1 GOTO Re_meas
3320 OUTPUT @Agt4294a;"USKEY"
3330 BEEP
3340 DISP "Select softkey to display each parameter."
3350 Loop:GOTO Loop
3360 !
3370 Disp_er_d: !
3380 DISP "Now loading data..."
3390 OUTPUT @Agt4294a;"MEAS CPD"
3400 OUTPUT @Agt4294a;"HIDI OFF;SPLD ON"
3410 OUTPUT @Agt4294a;"TRAC A"
3420 OUTPUT @Agt4294a;"INPUDTRC ";
3430 FOR I=1 TO Nop
3440   OUTPUT @Agt4294a;Err_data(I,1),Err_data(I,2);
3450 NEXT I
3460 OUTPUT @Agt4294a;" "
3470 OUTPUT @Agt4294a;"AUTO"
3480 OUTPUT @Agt4294a;"TRAC B"
3490 FOR I=1 TO Nop
3500   OUTPUT @Agt4294a;"INPUDTRC ";
3510   OUTPUT @Agt4294a;D_data(I,1),D_data(I,2);
3520 NEXT I
3530 OUTPUT @Agt4294a;" "
3540 OUTPUT @Agt4294a;"AUTO"
3550 OUTPUT @Agt4294a;"TRAC A"
3560 BEEP
3570 DISP "A: er'  B: tan d /  Thickness: ";T_dut*1000;"[mm]"
3580 RETURN
3590 !
3600 Disp_em_d: !
3610 DISP "Now loading data..."
3620 OUTPUT @Agt4294a;"MEAS CPD"
```

```

3630 OUTPUT @Agt4294a;"HIDI OFF;SPLD ON"
3640 OUTPUT @Agt4294a;"TRAC A"
3650 OUTPUT @Agt4294a;"INPUDTRC ";
3660 FOR I=1 TO Nop
3670     OUTPUT @Agt4294a;Erm_data(I,1),Erm_data(I,2);
3680 NEXT I
3690 OUTPUT @Agt4294a;""
3700 OUTPUT @Agt4294a;"AUTO"
3710 OUTPUT @Agt4294a;"TRAC B"
3720 FOR I=1 TO Nop
3730     OUTPUT @Agt4294a;"INPUDTRC ";
3740     OUTPUT @Agt4294a;D_data(I,1),D_data(I,2);
3750 NEXT I
3760 OUTPUT @Agt4294a;""
3770 OUTPUT @Agt4294a;"AUTO"
3780 OUTPUT @Agt4294a;"TRAC A"
3790 BEEP
3800 DISP "A: |er| B: tan d / Thickness: ";T_dut*1000;"[mm]"
3810 RETURN
3820 !
3830 Disp_er_ei: !
3840 DISP "Now loading data..."
3850 OUTPUT @Agt4294a;"MEAS CPD"
3860 OUTPUT @Agt4294a;"HIDI OFF;SPLD ON"
3870 OUTPUT @Agt4294a;"TRAC A"
3880 OUTPUT @Agt4294a;"INPUDTRC ";
3890 FOR I=1 TO Nop
3900     OUTPUT @Agt4294a;Err_data(I,1),Err_data(I,2);
3910 NEXT I
3920 OUTPUT @Agt4294a;""
3930 OUTPUT @Agt4294a;"AUTO"
3940 OUTPUT @Agt4294a;"TRAC B"
3950 FOR I=1 TO Nop
3960     OUTPUT @Agt4294a;"INPUDTRC ";
3970     OUTPUT @Agt4294a;Eri_data(I,1),Eri_data(I,2);
3980 NEXT I
3990 OUTPUT @Agt4294a;""
4000 OUTPUT @Agt4294a;"AUTO"
4010 OUTPUT @Agt4294a;"TRAC A"
4020 BEEP
4030 DISP "A: er' B: er'' / Thickness: ";T_dut*1000;"[mm]"
4040 RETURN
4050 !
4060 Disp_cole: !
4070 DISP "Now loading data..."
4080 OUTPUT @Agt4294a;"MEAS COMP"
4090 OUTPUT @Agt4294a;"HIDI ON;SPLD OFF"
4100 OUTPUT @Agt4294a;"TRAC A"
4110 OUTPUT @Agt4294a;"INPUDTRC ";
4120 FOR I=1 TO Nop
4130     OUTPUT @Agt4294a;Cole_data(I,1),Cole_data(I,2);
4140 NEXT I
4150 OUTPUT @Agt4294a;""
4160 OUTPUT @Agt4294a;"AUTO"
4170 BEEP
4180 DISP "Cole-cole Plot      Thickness: ";T_dut*1000;"[mm]"
4190 RETURN
4200 !
4210 Re_meas: !
4220 DISP "Measure once more?      0:Yes, 1:Cancel";
4230 INPUT "",Ans
4240 SELECT Ans
4250 CASE 0
4260     GOTO Meas

```

## Application Sample Programs

### Measuring Dielectric Material

```
4270 CASE 1
4280     GOTO Display
4290 CASE ELSE
4300     GOTO Re_meas
4310 END SELECT
4320 !
4330 Quit: !
4340 DISP "Really quit the program?      0:Yes, 1:Cancel";
4350 INPUT "",Ans
4360 SELECT Ans
4370 CASE 0
4380     DISP "Bye."
4390 CASE 1
4400     GOTO Display
4410 CASE ELSE
4420     GOTO Quit
4430 END SELECT
4440 END
```



### Sample Program for Non-Contacting Electrode Method

Example 13-3 shows a sample program to measure dielectric materials (non-contacting electrode method) (for HP Instrument BASIC). You can find the source file of this program, named `permi_nc.bas`, on the sample program disk. This program is very similar to Example 13-2, and therefore only its listing is given here.

#### Example 13-3 Dielectric (Relative Permittivity) Measurement (Non-Contacting Electrode Method)

```

10      !*****
20      !* 4294A + 16451B Permittivity Measurement (Non-Contact Method)
30      !* Instrument BASIC Sample Program
40      !*****
50      DIM Cp_data(1:801,1:2),D_data(1:801,1:2)
60      DIM Cp_data1(1:801,1:2),D_data1(1:801,1:2),Err_data(1:801,1:2)
70      DIM Cp_data2(1:801,1:2),D_data2(1:801,1:2),D_data3(1:801,1:2)
80      DIM Eri_data(1:801,1:2),Erm_data(1:801,1:2),Cole_data(1:801,1:2)
90      !
100     ASSIGN @Agt4294a TO 800
110     OUTPUT @Agt4294a;"DISA HIHB"
120     OUTPUT @Agt4294a;"HOLD"
130     !
140     Constants: !
150     E0=8.854E-12
160     Adj_center=100000.
170     Adj_up_limit_a=1.E-9
180     Adj_low_limit_a=7.E-10
190     Adj_up_limit_b=2.E-11
200     Adj_low_limit_b=1.2E-11
210     Load_center=100000.
220     Load_ave=4
230     Load_bw=5
240     Load_up_limit_a=5.05E-11 ! [pF]
250     Load_lo_limit_a=4.95E-11
260     Load_up_limit_b=5.05E-12
270     Load_lo_limit_b=4.95E-12
280     Open_r=1.E+11 ! [ohm]
290     Open_l=0
300     Short_r=0
310     Short_l=0
320     Load_g=0
330     Nop=201
340     Ave=1
350     Bw=3
360     D_elec_a=.038 ! [m]
370     D_elec_b=.005
380     !##### Main
390     Disp_proc:!
400     CLEAR SCREEN
410     PRINT "4294A + 16451B Permittivity Measurement Program"
420     PRINT " (Non-Contact Method Measurement)"
430     PRINT ""
440     PRINT "[ ] Select the main electrode of 16451B"
450     PRINT "[ ] Perform the adapter setup (1m cable)"
460     PRINT "[ ] Adjust the electrodes (Parallelizing)"
470     PRINT "[ ] Perform fixture compensation"
480     PRINT "x: done, s: skip, n: not required."
490     !
500     Adjustment: !
510     GOSUB Select_elec
520     GOSUB Adapter_setup
530     GOSUB Adjust
540     GOSUB Compen

```

## Application Sample Programs

### Measuring Dielectric Material

```
550 Meas: !
560 GOSUB Input_t
570 GOSUB Input_d
580 DISP "Create the electrode gap Tg. Press 'Continue' when ready"
590 PAUSE
600 GOSUB Input_tg
610 DISP "Insert MUT between electrodes and press 'Continue'"
620 PAUSE
630 GOSUB Sweep
640 FOR I=1 TO Nop
650   FOR J=1 TO 2
660     Cp_data2(I,J)=Cp_data(I,J)
670     D_data2(I,J)=D_data(I,J)
680   NEXT J
690 NEXT I
700 DISP "Remove MUT and press 'Continue'"
710 PAUSE
720 GOSUB Sweep
730 FOR I=1 TO Nop
740   FOR J=1 TO 2
750     Cp_data1(I,J)=Cp_data(I,J)
760     D_data1(I,J)=D_data(I,J)
770   NEXT J
780 NEXT I
790 GOSUB Calc
800 GOTO Display
810 !##### Sub-routines
820 Select_elec: !
830 PRINT TABXY(5,4);"->"
840 DISP "Which electrode of 16451B is used? 0:A, 1:B";
850 INPUT "",Ans
860 SELECT Ans
870 CASE 0
880   Elec$="A"
890   Adj_up_limit=Adj_up_limit_a
900   Adj_low_limit=Adj_low_limit_a
910   Load_up_limit=Load_up_limit_a
920   Load_low_limit=Load_lo_limit_a
930 CASE 1
940   Elec$="B"
950   Adj_up_limit=Adj_up_limit_b
960   Adj_low_limit=Adj_low_limit_b
970   Load_up_limit=Load_up_limit_b
980   Load_low_limit=Load_lo_limit_b
990 CASE ELSE
1000 GOTO Select_elec
1010 END SELECT
1020 DISP "The electrode ";Elec$;" is selected. OK? 0:OK, 1:No";
1030 INPUT "",Ans
1040 IF Ans<>0 THEN Select_elec
1050 PRINT TABXY(2,4);"x]  "
1060 RETURN
1070 !
1080 Adapter_setup: !
1090 DISP "Perform the adapter setup? 0:Yes, 1:Skip";
1100 INPUT "",Ans
1110 IF Ans=1 THEN
1120   PRINT TABXY(2,5);"s]  "
1130   RETURN
1140 END IF
1150 F_adapt_setup=1
1160 OUTPUT @Agt4294a;"PRES"
1170 PRINT TABXY(5,5);"->"
1180 DISP "Set the 16451B OPEN condition and press 'Continue'."
```

```

1190 PAUSE
1200 DISP "Wait until the setup is finished."
1210 OUTPUT @Agt4294a;"E4TP OFF;E4TP M1;ECALP"
1220 OUTPUT @Agt4294a;"*OPC?"
1230 ENTER @Agt4294a;Opc
1240 OUTPUT @Agt4294a;"ECALDON"
1250 DISP ""
1260 PRINT TABXY(2,5);"x]  "
1270 RETURN
1280 !
1290 Adjust: !
1300 IF Elec$="C" OR Elec$="D" THEN
1310     PRINT TABXY(2,6);"n]  "
1320     RETURN
1330 END IF
1340 IF F_adapt_setup=0 THEN
1350     DISP "Perform the electrode adjustment?      0:Yes, 1:Skip";
1360     INPUT "",Ans
1370     IF Ans=1 THEN
1380         PRINT TABXY(2,6);"s]  "
1390         RETURN
1400     END IF
1410 END IF
1420 F_adjust=1
1430 PRINT TABXY(5,6);"->"
1440 OUTPUT @Agt4294a;"SWPT LIN"
1450 OUTPUT @Agt4294a;"CENT ";Adj_center
1460 OUTPUT @Agt4294a;"SPAN ";0
1470 OUTPUT @Agt4294a;"POIN ";2
1480 OUTPUT @Agt4294a;"CALP USER"
1490 OUTPUT @Agt4294a;"MEAS CPD;TRAC A"
1500 OUTPUT @Agt4294a;"HIDI ON"
1510 OUTPUT @Agt4294a;"EDITLIML"
1520 OUTPUT @Agt4294a;"LIMCLEL ;LIMSADD"
1530 OUTPUT @Agt4294a;"LIMSTAR ";Adj_center
1540 OUTPUT @Agt4294a;"LIMSTOP ";Adj_center
1550 OUTPUT @Agt4294a;"LIMLSTAR ";Adj_low_limit
1560 OUTPUT @Agt4294a;"LIMUSTAR ";Adj_up_limit
1570 OUTPUT @Agt4294a;"LIMLSTOP ";Adj_low_limit
1580 OUTPUT @Agt4294a;"LIMUSTOP ";Adj_up_limit
1590 OUTPUT @Agt4294a;"LIMSDON;LIMEDONE"
1600 OUTPUT @Agt4294a;"TOPV ";1.5*Adj_up_limit-.5*Adj_low_limit
1610 OUTPUT @Agt4294a;"BOTV ";1.5*Adj_low_limit-.5*Adj_up_limit
1620 !
1630 OUTPUT @Agt4294a;"LIMITEST OFF"
1640 DISP "Set the micrometer of 16451B at 10um and press 'Continue'."
1650 PAUSE
1660 OUTPUT @Agt4294a;"LIMITEST ON"
1670 OUTPUT @Agt4294a;"CONT"
1680 OUTPUT @Agt4294a;"MKR ON"
1690 DISP "Adjust the electrode until PASS is displayed."
1700 PAUSE
1710 OUTPUT @Agt4294a;"HOLD"
1720 OUTPUT @Agt4294a;"OUTPFAIP?"
1730 ENTER @Agt4294a;F_nop
1740 IF F_nop<>0 THEN Adj
1750 OUTPUT @Agt4294a;"LIMITEST OFF"
1760 PRINT TABXY(2,6);"x]  "
1770 RETURN
1780 !
1790 Compen: !
1800 IF F_adjust=0 THEN
1810     DISP "Perform the fixture compensation?      0:Yes, 1:Skip";
1820     INPUT "",Ans

```

## Application Sample Programs

### Measuring Dielectric Material

```
1830     IF Ans=1 THEN
1840         PRINT TABXY(2,7);"s]   "
1850         RETURN
1860     END IF
1870 END IF
1880 PRINT TABXY(4,7);"->"
1890 Input_config:!
1900 DISP "Start frequency [Hz] = ?";
1910 INPUT "",Start
1920 DISP "Stop frequency [Hz] = ?";
1930 INPUT "",Stop
1940 DISP "Sweep type?  0:Linear, 1:Log";
1950 INPUT Ans
1960 IF Ans=1 THEN
1970     Swe_type$="LOG"
1980 ELSE
1990     Swe_type$="LIN"
2000 END IF
2010 DISP "OSC level [V] =?";
2020 INPUT "",Vosc
2030 DISP "Number of point?  [2-801]";
2040 INPUT Nop
2050 PRINT TABXY(1,10);"Start: ";Start;"[Hz]  Stop: ";Stop;"[Hz]";" Nop
: ";Nop
2060 PRINT TABXY(1,11);"Sweep Type: ";Swe_type$;"  OSC Level: ";Vosc;"[V
]";
2070 DISP "Measurement condition is OK?          0:OK, 1:NO";
2080 INPUT "",Ans
2090 IF Ans<>0 THEN Input_config
2100 !
2110 OUTPUT @Agt4294a;";;CALP USER"
2120 OUTPUT @Agt4294a;"MEAS CPD;TRAC A"
2130 OUTPUT @Agt4294a;"SWPT LIN"
2140 OUTPUT @Agt4294a;"CENT ";Load_center
2150 OUTPUT @Agt4294a;"SPAN 0"
2160 OUTPUT @Agt4294a;"POIN ";2
2170 OUTPUT @Agt4294a;"BWFACT ";Load_bw
2180 OUTPUT @Agt4294a;"PAVER ON;PAVERFACT ";Load_ave
2190 OUTPUT @Agt4294a;"LIMTEST ON;EDITLIML"
2200 OUTPUT @Agt4294a;"LIMCLEL ;LIMSADD"
2210 OUTPUT @Agt4294a;"LIMSTAR ";Load_center
2220 OUTPUT @Agt4294a;"LIMSTOP ";Load_center
2230 OUTPUT @Agt4294a;"LIMLSTAR ";Load_low_limit
2240 OUTPUT @Agt4294a;"LIMUSTAR ";Load_up_limit
2250 OUTPUT @Agt4294a;"LIMLSTOP ";Load_low_limit
2260 OUTPUT @Agt4294a;"LIMUSTOP ";Load_up_limit
2270 OUTPUT @Agt4294a;"LIMSDON;;LIMEDONE"
2280 OUTPUT @Agt4294a;"TOPV ";1.5*Load_up_limit-.5*Load_low_limit
2290 OUTPUT @Agt4294a;"BOTV ";1.5*Load_low_limit-.5*Load_up_limit
2300 OUTPUT @Agt4294a;"HIDI ON"
2310 !
2320 Load_adj:;!
2330 OUTPUT @Agt4294a;"CONT"
2340 OUTPUT @Agt4294a;"MKR ON"
2350 DISP "Turn the micrometer's knob until PASS is displayed."
2360 PAUSE
2370 OUTPUT @Agt4294a;"HOLD"
2380 OUTPUT @Agt4294a;"OUTPFAIP?"
2390 ENTER @Agt4294a;F_nop
2400 IF F_nop<>0 THEN Load_adj
2410 DISP ""
2420 OUTPUT @Agt4294a;"LIMTEST OFF"
2430 OUTPUT @Agt4294a;"OUTPDTRCP? 1"
2440 ENTER @Agt4294a;Load_c
```

```

2450 !
2460 OUTPUT @Agt4294a;"STAR ";Start
2470 OUTPUT @Agt4294a;"STOP ";Stop
2480 OUTPUT @Agt4294a;"SWPT ";Swe_type$
2490 OUTPUT @Agt4294a;"POIN ";Nop
2500 OUTPUT @Agt4294a;"BWFACT ";Bw
2510 OUTPUT @Agt4294a;"POWMOD VOLT;POWE ";Vosc
2520 OUTPUT @Agt4294a;"DCOMOPENG ";Load_g
2530 OUTPUT @Agt4294a;"DCOMOPENC ";Load_c/1.E-15
2540 OUTPUT @Agt4294a;"DCOMSHORR ";Short_r
2550 OUTPUT @Agt4294a;"DCOMSHORL ";Short_l
2560 OUTPUT @Agt4294a;"DCOMLOADR ";Open_r
2570 OUTPUT @Agt4294a;"DCOMLOADL ";Open_l
2580 !
2590 OUTPUT @Agt4294a;"COMA"
2600 DISP "Now measuring LOAD..."
2610 OUTPUT @Agt4294a;"*OPC?"
2620 ENTER @Agt4294a;Opc
2630 DISP "Set 16451B OPEN condition and press 'Continue'."
2640 PAUSE
2650 OUTPUT @Agt4294a;"COMC"
2660 DISP "Now measuring OPEN..."
2670 OUTPUT @Agt4294a;"*OPC?"
2680 ENTER @Agt4294a;Opc
2690 DISP "Set 16451B SHORT condition and press 'Continue'."
2700 PAUSE
2710 DISP "Now measuring SHORT..."
2720 OUTPUT @Agt4294a;"COMB"
2730 OUTPUT @Agt4294a;"*OPC?"
2740 ENTER @Agt4294a;Opc
2750 DISP ""
2760 PRINT TABXY(2,7);"x]  "
2770 RETURN
2780 !
2790 Input_t:!
2800 DISP "Thickness of MUT [mm] = ?";
2810 INPUT "",Ans
2820 T_dut=Ans/1000
2830 RETURN
2840 !
2850 Input_tg:!
2860 DISP "Distance of Electrode Gap Tg [mm] = ?";
2870 INPUT "",Ans
2880 Tg=Ans/1000
2890 RETURN
2900 !
2910 Input_d:!
2920 SELECT Elec$
2930 CASE "A"
2940   D_elec=D_elec_a
2950 CASE "B"
2960   D_elec=D_elec_b
2970 END SELECT
2980 RETURN
2990 !
3000 Sweep: !
3010 OUTPUT @Agt4294a;"DISA BASS"
3020 OUTPUT @Agt4294a;"MEAS CPD"
3030 OUTPUT @Agt4294a;"HIDI OFF"
3040 OUTPUT @Agt4294a;"SING"
3050 DISP "Now measuring Cp-D..."
3060 OUTPUT @Agt4294a;"*OPC?"
3070 ENTER @Agt4294a;Opc
3080 DISP "Now getting data..."

```

## Application Sample Programs

### Measuring Dielectric Material

```
3090 OUTPUT @Agt4294a;"TRAC A"
3100 OUTPUT @Agt4294a;"AUTO"
3110 OUTPUT @Agt4294a;"OUTPDTRC?"
3120 ENTER @Agt4294a USING "%,K";Cp_data(*)
3130 OUTPUT @Agt4294a;"TRAC B"
3140 OUTPUT @Agt4294a;"AUTO"
3150 OUTPUT @Agt4294a;"OUTPDTRC?"
3160 ENTER @Agt4294a USING "%,K";D_data(*)
3170 RETURN
3180 !
3190 Calc: !
3200 FOR I=1 TO Nop
3210   D_data3(I,1)=(D_data2(I,1)+Err_data(I,1)*(D_data2(I,1)-D_data1
(I,1))*(Tg/T_dut)-1))
3220   D_data3(I,2)=0
3230   Err_data(I,1)=1/(1-(1-(Cp_data1(I,1)/Cp_data2(I,1)))*(Tg/T_dut))
3240   Err_data(I,2)=0
3250   Eri_data(I,1)=Err_data(I,1)*D_data3(I,1)
3260   Eri_data(I,2)=0
3270   Erm_data(I,1)=SQR(Err_data(I,1)^2+Eri_data(I,1)^2)
3280   Erm_data(I,2)=0
3290   Cole_data(I,1)=Err_data(I,1)
3300   Cole_data(I,2)=Eri_data(I,1)
3310 NEXT I
3320 RETURN
3330 !
3340 Display: !
3350 ON KEY 1 LABEL "er' -          tan d",1 GOSUB Disp_er_d
3360 ON KEY 2 LABEL "|er| -         tan d",1 GOSUB Disp_em_d
3370 ON KEY 3 LABEL "er' -          er'",1 GOSUB Disp_er_ei
3380 ON KEY 4 LABEL "Cole-cole      Plot",1 GOSUB Disp_cole
3390 ON KEY 7 LABEL "Quit",1 GOTO Quit
3400 ON KEY 8 LABEL "Re-measure",1 GOTO Re_meas
3410 OUTPUT @Agt4294a;"USKEY"
3420 BEEP
3430 DISP "Select softkey to display each parameter."
3440 Loop: GOTO Loop
3450 !
3460 Disp_er_d: !
3470 DISP "Now loading data..."
3480 OUTPUT @Agt4294a;"MEAS CPD"
3490 OUTPUT @Agt4294a;"HIDI OFF;SPLD ON"
3500 OUTPUT @Agt4294a;"TRAC A"
3510 OUTPUT @Agt4294a;"INPUDTRC ";
3520 FOR I=1 TO Nop
3530   OUTPUT @Agt4294a;Err_data(I,1),Err_data(I,2);
3540 NEXT I
3550 OUTPUT @Agt4294a;" "
3560 OUTPUT @Agt4294a;"AUTO"
3570 OUTPUT @Agt4294a;"TRAC B"
3580 FOR I=1 TO Nop
3590   OUTPUT @Agt4294a;"INPUDTRC ";
3600   OUTPUT @Agt4294a;D_data3(I,1),D_data3(I,2);
3610 NEXT I
3620 OUTPUT @Agt4294a;" "
3630 OUTPUT @Agt4294a;"AUTO"
3640 OUTPUT @Agt4294a;"TRAC A"
3650 BEEP
3660 DISP "A: er'  B: tan d /  Thickness: ";T_dut*1000;"[mm]"
3670 RETURN
3680 !
3690 Disp_em_d: !
3700 DISP "Now loading data..."
3710 OUTPUT @Agt4294a;"MEAS CPD"
```

```

3720 OUTPUT @Agt4294a;"HIDI OFF;SPLD ON"
3730 OUTPUT @Agt4294a;"TRAC A"
3740 OUTPUT @Agt4294a;"INPUDTRC ";
3750 FOR I=1 TO Nop
3760   OUTPUT @Agt4294a;Erm_data(I,1),Erm_data(I,2);
3770 NEXT I
3780 OUTPUT @Agt4294a;""
3790 OUTPUT @Agt4294a;"AUTO"
3800 OUTPUT @Agt4294a;"TRAC B"
3810 FOR I=1 TO Nop
3820   OUTPUT @Agt4294a;"INPUDTRC ";
3830   OUTPUT @Agt4294a;D_data3(I,1),D_data3(I,2);
3840 NEXT I
3850 OUTPUT @Agt4294a;""
3860 OUTPUT @Agt4294a;"AUTO"
3870 OUTPUT @Agt4294a;"TRAC A"
3880 BEEP
3890 DISP "A: |er| B: tan d / Thickness: ";T_dut*1000;"[mm]"
3900 RETURN
3910 !
3920 Disp_er_ei: !
3930 DISP "Now loading data..."
3940 OUTPUT @Agt4294a;"MEAS CPD"
3950 OUTPUT @Agt4294a;"HIDI OFF;SPLD ON"
3960 OUTPUT @Agt4294a;"TRAC A"
3970 OUTPUT @Agt4294a;"INPUDTRC ";
3980 FOR I=1 TO Nop
3990   OUTPUT @Agt4294a;Err_data(I,1),Err_data(I,2);
4000 NEXT I
4010 OUTPUT @Agt4294a;""
4020 OUTPUT @Agt4294a;"AUTO"
4030 OUTPUT @Agt4294a;"TRAC B"
4040 FOR I=1 TO Nop
4050   OUTPUT @Agt4294a;"INPUDTRC ";
4060   OUTPUT @Agt4294a;Eri_data(I,1),Eri_data(I,2);
4070 NEXT I
4080 OUTPUT @Agt4294a;""
4090 OUTPUT @Agt4294a;"AUTO"
4100 OUTPUT @Agt4294a;"TRAC A"
4110 BEEP
4120 DISP "A: er' B: er'' / Thickness: ";T_dut*1000;"[mm]"
4130 RETURN
4140 !
4150 Disp_cole: !
4160 DISP "Now loading data..."
4170 OUTPUT @Agt4294a;"MEAS COMP"
4180 OUTPUT @Agt4294a;"HIDI ON;SPLD OFF"
4190 OUTPUT @Agt4294a;"TRAC A"
4200 OUTPUT @Agt4294a;"INPUDTRC ";
4210 FOR I=1 TO Nop
4220   OUTPUT @Agt4294a;Cole_data(I,1),Cole_data(I,2);
4230 NEXT I
4240 OUTPUT @Agt4294a;""
4250 OUTPUT @Agt4294a;"AUTO"
4260 BEEP
4270 DISP "Cole-cole Plot      Thickness: ";T_dut*1000;"[mm]"
4280 RETURN
4290 !
4300 Re_meas: !
4310 DISP "Measure once more?      0:Yes, 1:Cancel";
4320 INPUT "",Ans
4330 SELECT Ans
4340 CASE 0
4350   GOTO Meas

```

## Application Sample Programs

### Measuring Dielectric Material

```
4360 CASE 1
4370     GOTO Display
4380 CASE ELSE
4390     GOTO Re_meas
4400 END SELECT
4410 !
4420 Quit: !
4430 DISP "Really quit the program?      0:Yes, 1:Cancel";
4440 INPUT "",Ans
4450 SELECT Ans
4460 CASE 0
4470     DISP "Bye."
4480 CASE 1
4490     GOTO Display
4500 CASE ELSE
4510     GOTO Quit
4520 END SELECT
4530 END
```



## Measuring Magnetic Materials

This section describes how to measure magnetic materials using the 4294A (and the 42942A terminal adapter) and the 16454A magnetic material test fixture.

### Measurement Procedure

Figure 13-2 shows the flow of magnetic material measurement.

Figure 13-4

#### Flow of Magnetic Material Measurement

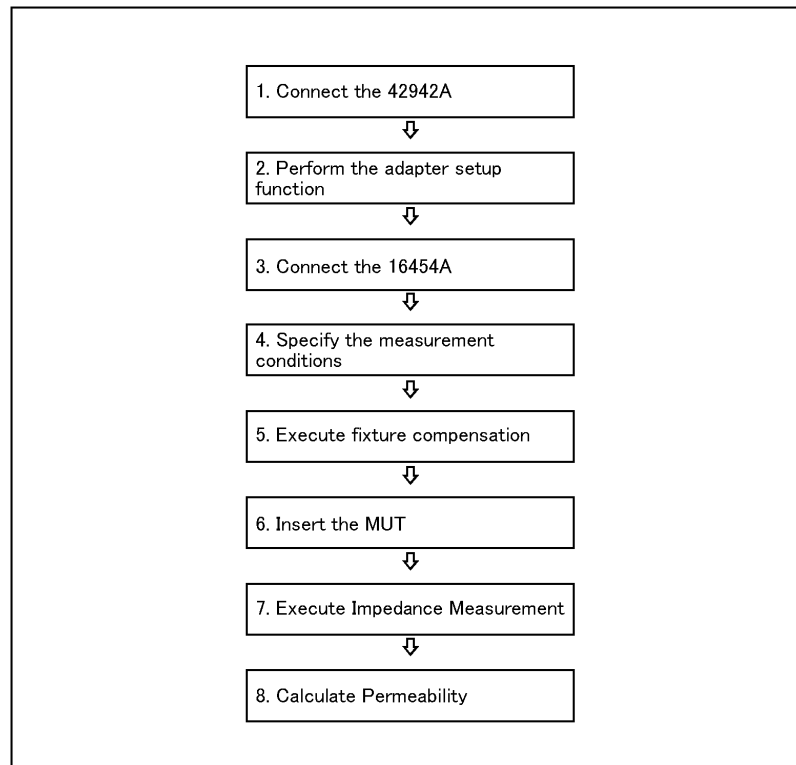

4294ape038

#### Step 1. Connect the 42942A

Connect the 42942A to the UNKNOWN terminal of the 4294A.

#### Step 2. Perform the adapter setup function

Select 7mm 42942A as the adapter, measure phase/OPEN/SHORT/LOAD data for calculating the setup data, calculate the setup data, and store it into the nonvolatile memory.

#### NOTE

For details on how to set up the adapter when connecting the 42942A, refer to “Preparing Accessories for Measurement” in the 4294A Operation Manual.

**Step 3.** Connect the 16454A

Connect either the small or large electrode of 16454A (whose size is suitable for the shape of the magnetic material (MUT) you want to measure) to the 42942A.

**NOTE**

For details on how to handle the 16454A (the dimensions of the MUT suitable for measurement in each size (small or large)), refer to the 16454A Operation and Service Manual.

**Step 4.** Specify the measurement conditions

Specify the measurement conditions including the measurement frequency and the measurement signal level.

**Step 5.** Execute fixture compensation

Insert only the MUT holder and perform SHORT compensation

**Step 6.** Insert the MUT

Insert the MUT with the holder into the 16454A.

**Step 7.** Execute impedance measurement

Measure the impedance (R + jX).

**Step 8.** Calculate permeability

Using the following expressions and the result of the impedance measurement, calculate the complex relative permeability ( $\dot{\mu}_r = \mu_r' - j \mu_r''$ ) and the loss tangent ( $\tan \delta$ ) of the MUT.

**Equation 13-3 Expressions to calculate the complex relative permeability and the loss tangent**

$$\dot{\mu}_r = \frac{\dot{Z}_m}{j(f \times \mu_0 \times h \times \ln(c/b))} + 1 = \frac{X}{f \times \mu_0 \times h \times \ln(c/b)} + 1 - j \frac{R}{f \times \mu_0 \times h \times \ln(c/b)}$$

$$\mu_r' = \frac{X}{f \times \mu_0 \times h \times \ln(c/b)} + 1 \qquad \mu_r'' = \frac{R}{f \times \mu_0 \times h \times \ln(c/b)}$$

$$\tan \delta = \frac{\mu_r''}{\mu_r'}$$

Where,

$\dot{\mu}_r$	Complex relative permeability of MUT
$\dot{Z}_m = R + jX$	Impedance (complex number) [ $\Omega$ ]
$\mu_0$	Permeability of vacuum (=1.257×10 <sup>-6</sup> ) [H/m]
$f$	Frequency [Hz]
$h$	Height of MUT [m]
$c$	Outside diameter of MUT [m]
$b$	Inside diameter of MUT [m]

## Sample Program

Example 13-4 shows a sample program to measure magnetic materials (for HP Instrument BASIC). You can find the source file of this program, named permeabi.bas, on the sample program disk.

How to use the program is described below:

- Step 1.** Connect the 42942A terminal adapter to the 4294A, and start this program. When the message “Perform the adapter setup? 0:Yes, 1:Skip” is displayed, enter 0 if you want to set up the adapter.
- Step 2.** When the message “Connect OPEN (0S) to the 7mm port and press 'Continue'.” is displayed, connect OPEN to the 42942A and press the **Continue** key (2nd softkey from the top). The phase data and OPEN data for calculating the setup data will be measured.
- Step 3.** When the message “Connect SHORT (0-OHM) to the 7mm port and press 'Continue'.” is displayed, connect SHORT to the 42942A and press the **Continue** key to measure the SHORT data for calculating the setup data.
- Step 4.** When the message “Connect LOAD (50-OHM) to the 7mm port and press 'Continue'.” is displayed, connect LOAD to the 42942A and press the **Continue** key to measure the SHORT data for calculating the setup data.
- Step 5.** When the message “Connect the 16454A to the 7mm port and press 'Continue'.” is displayed, connect the 16454A to the 42942A and press the **Continue** key.
- Step 6.** When the message “Start frequency [Hz] = ?” is displayed, enter the frequency at the sweep start point. In the same way, enter the frequency at the sweep end point, the sweep type, the signal source level, the number of measurement points, and the band width. When you have completed all entries, they are displayed followed by the message “Measurement condition is OK? 0:OK, 1:NO”. If you find no mistake, enter 0.
- Step 7.** When the message “Insert the MUT holder (without MUT) and press 'Continue'.” is displayed, make sure that only the holder is inserted into the 16454A and press the **Continue** key to measure the SHORT data for fixture compensation.
- Step 8.** When the message “Outer diameter of MUT [mm] = ?” is displayed, enter the outside diameter of the MUT. In the same way, enter the inside diameter and the height of the MUT.
- Step 9.** When the message “Insert MUT (with holder) into fixture and press 'Continue'.” is displayed, insert the MUT into the 16454A together with the holder and press the **Continue** key to measure the impedance.
- Step 10.** When the message “Select softkey to display each parameter.” is displayed, press the softkey for the parameter you want to display on the screen. Figure 13-5 shows an example of the screen display when selecting the real part ( $\mu_r'$ ) and the imaginary part ( $\mu_r''$ ) of the complex relative permeability as displayed parameters. At this time, pressing the “Quit” softkey terminates the program and pressing the “Re-measure” softkey lets you repeat the procedure from Step 8.

Figure 13-5

Example of the Result of Executing the Program of Example 13-4

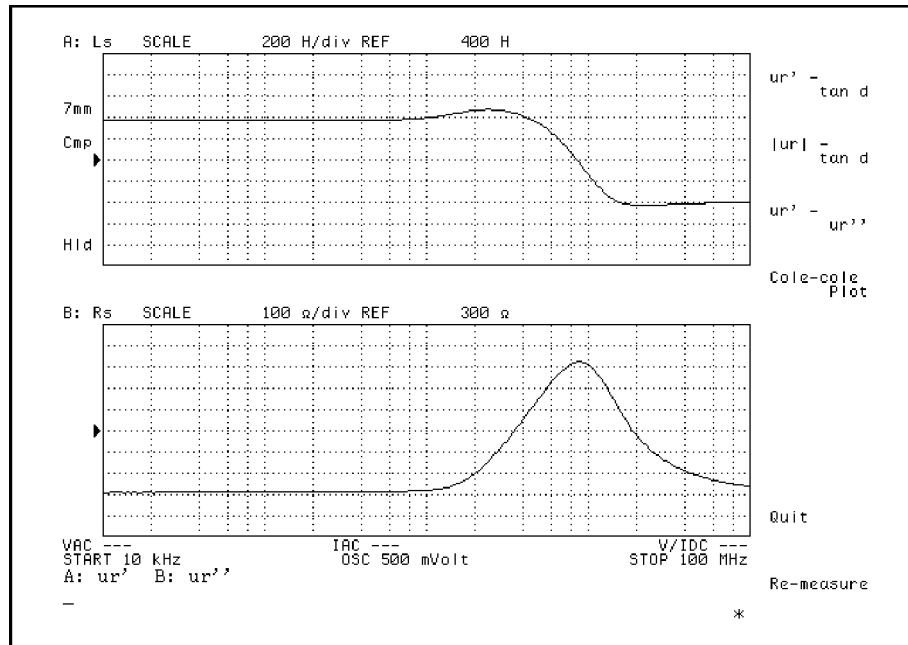

4294apj040

The program is described in detail below:

- Lines 90 to 100    Sets the GPIB address and select code.
- Lines 110 to 120    Assigns the upper half of the LCD screen to measurement result display and the lower half to the HP Instrument BASIC, and stops the sweep.
- Line 150            Stores the permeability of vacuum into the U0 variable.
- Lines 170 to 230    Displays the message at the start of the program.
- Line 260            Passes control to a subroutine named Adapter\_setup to set up the adapter.
- Line 270            Passes control to a subroutine named Fixt\_compen to execute fixture compensation.
- Line 290            Passes control to a subroutine named Input\_size to set the outside diameter, inside diameter, and height of the MUT.
- Line 300            Passes control to a subroutine named Sweep to perform measurement.
- Line 310            Passes control to a subroutine named Calc to calculate each parameter.
- Line 320            Jumps to the Display line and displays each parameter.
- Lines 350 to 860    The Adapter\_setup subroutine.
  - Lines 360 to 420: Sets 42942A as the adapter and asks you if you want to perform adapter setup.
  - Lines 440 to 460: After reset, makes the setting to use SRQ.
  - Lines 480 to 500: After clearing the register, sets the branch destination for an SRQ interrupt, and enables the SRQ interrupt.

Lines 510 to 630: When you finish connecting OPEN and press the **Continue** key, measures phase and OPEN with the same connection.

Lines 640 to 810: Measures SHORT and LOAD in the same way.

Lines 820 to 850: Calculates the setup data and saves it into the nonvolatile memory.

Lines 880 to 1400 The Fixt\_compen subroutine.

Lines 890 to 900: Waits until you connect the 16454A and press the **Continue** key.

Lines 920 to 970: Asks you if you want to execute fixture compensation.

Lines 1000 to 1220: Obtains the setting values (the sweep range, the sweep type, the signal source level, and the number of measurement points) from user input.

Lines 1240 to 1310: Sets up the measurement conditions.

Lines 1320 to 1370: After you finish the connection for SHORT measurement of the 16454A and press the **Continue** key, SHORT measurement is performed.

Lines 1420 to 1520 The Input\_size subroutine. Sets the outside diameter, inside diameter, and height of the MUT from user input.

Lines 1540 to 1750 The Sweep subroutine.

Lines 1550 to 1560: Waits until you insert an MUT into the 16454A and press the **Continue** key.

Lines 1570 to 1630: Measures R and X.

Lines 1640 to 1720: Retrieves the measurement results and the frequency setting and stores them into the R\_data, X\_data, and Freq arrays.

Lines 1770 to 1920 The Calc subroutine. Using the R\_data, X\_data, and Freq arrays, calculates the complex relative permeability and the loss tangent.

Lines 1950 to 2040 Sets the softkey labels and the subroutines to be executed when each key is pressed. Then, waits until you press one of the softkeys.

Lines 2060 to 2270 Processing when the softkey labeled as “ur' - tan d” is pressed. Displays the real part of the complex relative permeability ( $\mu_r'$ ) as trace A and the loss tangent as trace B.

Lines 2290 to 2500 Processing when the softkey labeled as “|ur| - tan d” is pressed. Displays the amplitude of the complex relative permeability ( $\sqrt{\mu_r'^2 + \mu_r''^2}$ ) as trace A and the loss tangent as trace B.

Lines 2520 to 2730 Processing when the softkey labeled as “ur' - ur” is pressed. Displays the real part of the complex relative permeability ( $\mu_r'$ ) as trace A and the imaginary part of the complex relative permeability ( $\mu_r''$ ) as trace B.

## Application Sample Programs Measuring Magnetic Materials

Lines 2750 to 2880 Processing when the softkey labeled as “Cole-cole Plot” is pressed  
Displays the COLE-COLE plot on the complex plane.

Lines 2900 to 3000 Processing when the softkey labeled as “Re-measure” is pressed.

Lines 3020 to 3120 Processing when the softkey labeled as “Quit” is pressed.

### Example 13-4

### Magnetic Material (Relative Permeability) Measurement

```
10  !*****
20  !* 4294A + 16454A Permeability Measurement
30  !* Instrument BASIC Sample Program
40  !*****
50  DIM R_data(1:801,1:2),X_data(1:801,1:2),Freq(1:801)
60  DIM Urr_data(1:801,1:2),Uri_data(1:801,1:2),Urm_data(1:801,1:2)
70  DIM Cole_data(1:801,1:2),Tan_d_data(1:801,1:2)
80  !
90  ASSIGN @Agt4294a TO 800
100 Scode=8
110 OUTPUT @Agt4294a;"DISA HIHB"
120 OUTPUT @Agt4294a;"HOLD"
130 !
140 Constants:  !
150 U0=1.257E-6
160 !##### Main
170 Disp_proc: !
180 CLEAR SCREEN
190 PRINT "4294A + 16454A Permeability Measurement Program"
200 PRINT ""
210 PRINT "[ ] Perform the adapter setup (7mm)"
220 PRINT "[ ] Perform fixture compensation"
230 PRINT "x: done, s: skip."
240 !
250 Adjustment: !
260 GOSUB Adapter_setup
270 GOSUB Fixt_compen
280 Meas:!
290 GOSUB Input_size
300 GOSUB Sweep
310 GOSUB Calc
320 GOTO Display
330 !
340 !##### Sub-routines
350 Adapter_setup: !
360 OUTPUT @Agt4294a;"E4TP APC7"
370 DISP "Perform the adapter setup? 0:Yes, 1:Skip";
380 INPUT "",Ans
390 IF Ans=1 THEN
400 PRINT TABXY(2,3);"s]  "
410 RETURN
420 END IF
430 F_adapt_setup=1
440 OUTPUT @Agt4294a;"PRES"
450 PRINT TABXY(5,3);"->"
460 OUTPUT @Agt4294a;"ESNB 256; *SRE 4"
470 !
480 OUTPUT @Agt4294a;"*CLS"
490 ON INTR Scode GOTO Phase_meas_end
500 ENABLE INTR Scode;2
510 DISP "Connect OPEN (0S) to the 7mm port and press 'Continue'."
520 PAUSE
530 DISP "Now measuring PHASE data..."
540 OUTPUT @Agt4294a;"ECALP"
550 Phase_meas_wait: GOTO Phase_meas_wait
```

```

560 Phase_meas_end: !
570   OUTPUT @Agt4294a;"*CLS"
580   ON INTR Scode GOTO Open_meas_end
590   ENABLE INTR Scode;2
600   DISP "Now measuring OPEN data..."
610   OUTPUT @Agt4294a;"ECALA"
620 Open_meas_wait: GOTO Open_meas_wait
630 Open_meas_end: !
640   OUTPUT @Agt4294a;"*CLS"
650   ON INTR Scode GOTO Short_meas_end
660   ENABLE INTR Scode;2
670   DISP "Connect SHORT (0-OHM) to the 7mm port and press 'Continue'."
680   PAUSE
690   DISP "Now measuring SHORT data..."
700   OUTPUT @Agt4294a;"ECALB"
710 Short_meas_wait: GOTO Short_meas_wait
720 Short_meas_end: !
730   OUTPUT @Agt4294a;"*CLS"
740   ON INTR Scode GOTO Load_meas_end
750   ENABLE INTR Scode;2
760   DISP "Connect LOAD (50-OHM) to the 7mm port and press 'Continue'."
770   PAUSE
780   DISP "Now measuring LOAD data..."
790   OUTPUT @Agt4294a;"ECALC"
800 Load_meas_wait: GOTO Load_meas_wait
810 Load_meas_end: !
820   DISP "Now storing setup data..."
830   OUTPUT @Agt4294a;"ECALDON"
840   DISP ""
850   PRINT TABXY(2,3);"x]  "
860   RETURN
870   !
880 Fixt_compen: !
890   DISP "Connect the 16454A to the 7mm port and press 'Continue'."
900   PAUSE
910   IF F_adapt_setup=0 THEN
920     DISP "Perform the fixture compensation?  0:Yes, 1:Skip";
930     INPUT "",Ans
940     IF Ans=1 THEN
950       PRINT TABXY(2,4);"s]  "
960       RETURN
970     END IF
980   END IF
990   PRINT TABXY(4,4);"->"
1000 Input_config:!
1010 DISP "Start frequency [Hz] = ?";
1020 INPUT "",Start
1030 DISP "Stop frequency [Hz] = ?";
1040 INPUT "",Stop
1050 DISP "Sweep type?  0:Linear, 1:Log";
1060 INPUT Ans
1070 IF Ans=1 THEN
1080   Swe_type$="LOG"
1090 ELSE
1100   Swe_type$="LIN"
1110 END IF
1120 DISP "OSC level [V] =?";
1130 INPUT "",Vosc
1140 DISP "Number of point?  [2-801]";
1150 INPUT Nop
1160 DISP "BW ?  [1-5]";
1170 INPUT Bw
1180 PRINT TABXY(1,10);"Start: ";Start;" [Hz]  Stop: ";Stop;" [Hz]";" Nop
: ";Nop

```

## Application Sample Programs

### Measuring Magnetic Materials

```
1190 PRINT TABXY(1,11);"Sweep Type: ";Swe_type$;" OSC Level:";Vosc;"[V
] BW: ";Bw;
1200 DISP "Measurement condition is OK?          0:OK, 1:NO";
1210 INPUT "",Ans
1220 IF Ans<>0 THEN Input_config
1230 !
1240 OUTPUT @Agt4294a;"CALP USER"
1250 OUTPUT @Agt4294a;"MEAS IRIM"
1260 OUTPUT @Agt4294a;"STAR ";Start
1270 OUTPUT @Agt4294a;"STOP ";Stop
1280 OUTPUT @Agt4294a;"SWPT ";Swe_type$
1290 OUTPUT @Agt4294a;"POIN ";Nop
1300 OUTPUT @Agt4294a;"BWFACT ";Bw
1310 OUTPUT @Agt4294a;"POWMOD VOLT;POWE ";Vosc
1320 DISP "Insert the MUT holder (without MUT) and press 'Continue'."
1330 PAUSE
1340 DISP "Now measuring SHORT data..."
1350 OUTPUT @Agt4294a;"COMB"
1360 OUTPUT @Agt4294a;"*OPC?"
1370 ENTER @Agt4294a;Opc
1380 DISP ""
1390 PRINT TABXY(2,4);"x]  "
1400 RETURN
1410 !
1420 Input_size: !
1430 DISP "Outer diameter of MUT [mm] = ?";
1440 INPUT "",Ans
1450 C=Ans/1000
1460 DISP "Inner diameter of MUT [mm] = ?";
1470 INPUT "",Ans
1480 B=Ans/1000
1490 DISP "Height of MUT [mm] = ?";
1500 INPUT "",Ans
1510 H=Ans/1000
1520 RETURN
1530 !
1540 Sweep: !
1550 DISP "Insert MUT (with holder) into fixture and press 'Continue'."
1560 PAUSE
1570 OUTPUT @Agt4294a;"DISA BASS"
1580 OUTPUT @Agt4294a;"MEAS IRIM"
1590 OUTPUT @Agt4294a;"HIDI OFF"
1600 OUTPUT @Agt4294a;"SING"
1610 DISP "Now measuring R-X..."
1620 OUTPUT @Agt4294a;"*OPC?"
1630 ENTER @Agt4294a;Opc
1640 DISP "Now getting data..."
1650 OUTPUT @Agt4294a;"TRAC A"
1660 OUTPUT @Agt4294a;"AUTO"
1670 OUTPUT @Agt4294a;"OUTPDTRC?"
1680 ENTER @Agt4294a USING "%,K";R_data(*)
1690 OUTPUT @Agt4294a;"TRAC B"
1700 OUTPUT @Agt4294a;"AUTO"
1710 OUTPUT @Agt4294a;"OUTPDTRC?"
1720 ENTER @Agt4294a USING "%,K";X_data(*)
1730 OUTPUT @Agt4294a;"OUTPSWPRM?"
1740 ENTER @Agt4294a USING "%,K";Freq(*)
1750 RETURN
1760 !
1770 Calc: !
1780 OUTPUT @Agt4294a;"POIN?"
1790 ENTER @Agt4294a;Nop
1800 FOR I=1 TO Nop
1810   Urr_data(I,1)=(X_data(I,1)/(Freq(I)*U0*H*LOG(C/B)))+1
```



```

1820   Urr_data(I,2)=0
1830   Uri_data(I,1)=R_data(I,1)/(Freq(I)*U0*H*LOG(C/B))
1840   Uri_data(I,2)=0
1850   Tan_d_data(I,1)=Uri_data(I,1)/ABS(Urr_data(I,1))
1860   Tan_d_data(I,2)=0
1870   Urm_data(I,1)=SQR(Urr_data(I,1)^2+Uri_data(I,1)^2)
1880   Urm_data(I,2)=0
1890   Cole_data(I,1)=Urr_data(I,1)
1900   Cole_data(I,2)=Uri_data(I,1)
1910 NEXT I
1920 RETURN
1930 !
1940 Display: !
1950 ON KEY 1 LABEL "ur' -          tan d",1 GOSUB Disp_ur_d
1960 ON KEY 2 LABEL "|ur| -          tan d",1 GOSUB Disp_um_d
1970 ON KEY 3 LABEL "ur' -          ur'",1 GOSUB Disp_ur_ui
1980 ON KEY 4 LABEL "Cole-cole      Plot",1 GOSUB Disp_cole
1990 ON KEY 7 LABEL "Quit",1 GOTO Quit
2000 ON KEY 8 LABEL "Re-measure",1 GOTO Re_meas
2010 OUTPUT @Agt4294a;"USKEY"
2020 BEEP
2030 DISP "Select softkey to display each parameter."
2040 Loop: GOTO Loop
2050 !
2060 Disp_ur_d: !
2070 DISP "Now loading data..."
2080 OUTPUT @Agt4294a;"MEAS IMD"
2090 OUTPUT @Agt4294a;"HIDI OFF;SPLD ON"
2100 OUTPUT @Agt4294a;"TRAC A"
2110 OUTPUT @Agt4294a;"INPUDTRC ";
2120 FOR I=1 TO Nop
2130   OUTPUT @Agt4294a;Urr_data(I,1),Urr_data(I,2);
2140 NEXT I
2150 OUTPUT @Agt4294a;" "
2160 OUTPUT @Agt4294a;"AUTO"
2170 OUTPUT @Agt4294a;"TRAC B"
2180 FOR I=1 TO Nop
2190   OUTPUT @Agt4294a;"INPUDTRC ";
2200   OUTPUT @Agt4294a;Tan_d_data(I,1),Tan_d_data(I,2);
2210 NEXT I
2220 OUTPUT @Agt4294a;" "
2230 OUTPUT @Agt4294a;"AUTO"
2240 OUTPUT @Agt4294a;"TRAC A"
2250 BEEP
2260 DISP "A: ur'  B: tan d "
2270 RETURN
2280 !
2290 Disp_um_d: !
2300 DISP "Now loading data..."
2310 OUTPUT @Agt4294a;"MEAS IMD"
2320 OUTPUT @Agt4294a;"HIDI OFF;SPLD ON"
2330 OUTPUT @Agt4294a;"TRAC A"
2340 OUTPUT @Agt4294a;"INPUDTRC ";
2350 FOR I=1 TO Nop
2360   OUTPUT @Agt4294a;Urm_data(I,1),Urm_data(I,2);
2370 NEXT I
2380 OUTPUT @Agt4294a;" "
2390 OUTPUT @Agt4294a;"AUTO"
2400 OUTPUT @Agt4294a;"TRAC B"
2410 FOR I=1 TO Nop
2420   OUTPUT @Agt4294a;"INPUDTRC ";
2430   OUTPUT @Agt4294a;Tan_d_data(I,1),Tan_d_data(I,2);
2440 NEXT I
2450 OUTPUT @Agt4294a;" "

```

## Application Sample Programs

### Measuring Magnetic Materials

```
2460 OUTPUT @Agt4294a;"AUTO"
2470 OUTPUT @Agt4294a;"TRAC A"
2480 BEEP
2490 DISP "A: |ur| B: tan d "
2500 RETURN
2510 !
2520 Disp_ur_ui: !
2530 DISP "Now loading data..."
2540 OUTPUT @Agt4294a;"MEAS LSR"
2550 OUTPUT @Agt4294a;"HIDI OFF;SPLD ON"
2560 OUTPUT @Agt4294a;"TRAC A"
2570 OUTPUT @Agt4294a;"INPUDTRC ";
2580 FOR I=1 TO Nop
2590     OUTPUT @Agt4294a;Urr_data(I,1),Urr_data(I,2);
2600 NEXT I
2610 OUTPUT @Agt4294a;" "
2620 OUTPUT @Agt4294a;"AUTO"
2630 OUTPUT @Agt4294a;"TRAC B"
2640 FOR I=1 TO Nop
2650     OUTPUT @Agt4294a;"INPUDTRC ";
2660     OUTPUT @Agt4294a;Uri_data(I,1),Uri_data(I,2);
2670 NEXT I
2680 OUTPUT @Agt4294a;" "
2690 OUTPUT @Agt4294a;"AUTO"
2700 OUTPUT @Agt4294a;"TRAC A"
2710 BEEP
2720 DISP "A: ur' B: ur'' "
2730 RETURN
2740 !
2750 Disp_cole: !
2760 DISP "Now loading data..."
2770 OUTPUT @Agt4294a;"MEAS COMP"
2780 OUTPUT @Agt4294a;"HIDI ON;SPLD OFF"
2790 OUTPUT @Agt4294a;"TRAC A"
2800 OUTPUT @Agt4294a;"INPUDTRC ";
2810 FOR I=1 TO Nop
2820     OUTPUT @Agt4294a;Cole_data(I,1),Cole_data(I,2);
2830 NEXT I
2840 OUTPUT @Agt4294a;" "
2850 OUTPUT @Agt4294a;"AUTO"
2860 BEEP
2870 DISP "Cole-cole Plot"
2880 RETURN
2890 !
2900 Re_meas: !
2910 DISP "Measure once more?          0:Yes, 1:Cancel";
2920 INPUT "",Ans
2930 SELECT Ans
2940 CASE 0
2950     GOTO Meas
2960 CASE 1
2970     GOTO Display
2980 CASE ELSE
2990     GOTO Re_meas
3000 END SELECT
3010 !
3020 Quit: !
3030 DISP "Really quit the program?      0:Yes, 1:Cancel";
3040 INPUT "",Ans
3050 SELECT Ans
3060 CASE 0
3070     DISP "Bye."
3080 CASE 1
3090     GOTO Display
```

```
3100 CASE ELSE
3110     GOTO Quit
3120 END SELECT
3130 END
```

---

## Measurement controlling oscillator level

Example 13-5 shows a sample program of a measurement by correctly applying specified test signal level at DUT using the oscillator level monitor function. This program is stored on the sample program disk as the alc.bas file.

Connect the Agilent 16047E test fixture for lead parts to the Agilent 4294A, and then start this program. When “Set Open-Connection” appears, make the connection to measure data for open compensation, and press the **[y]** key and the **[Enter]** key. Then, when “Set Short-Connection” appears, perform the same operation to measure data for short compensation.

---

### NOTE

For how to use the 16047E, for example, the connection to measure data for open/short compensation, refer to its manual.

Then, when “Set DUT, then Push [Enter] key” appears, mount an DUT onto the test fixture, and then press the **[Enter]** key. A measurement is operated at each measurement point using the manual sweep function, and the measurement result is displayed (refer to Figure 13-6). At the each measurement, the oscillator level is controlled to apply the correct signal level at DUT. After the completion of measurements at all points, “Once more? [Y]es/[N]o” appears. If you want to measure the capacitor again or another DUT, press the **[y]** key and the **[Enter]** key to continue the measurement. If you want to finish the measurement, press a key other than the **[y]** key and the **[Enter]** key.

- |                  |  |
|------------------|--|
| Lines 80 to 140  | Identifies the external controller and Instrument BASIC and sets the GPIB address and the select code.   |
| Lines 160 to 250 | Substitutes the measurement conditions (adapter setting: NONE, measurement parameter: $ Z -\theta$ , sweep type: LOG, sweep start value: 1 kHz, sweep stop value: 10 MHz, Number of measurement points: 21, trace A display format: logarithmic Y axis, trace B display format: linear Y axis, oscillator level mode: CURR, test signal level: 1 mA) into the variables: Adapter\$, Meas_para\$, Swp_type\$, Start, Stop, Nop, Fmt_a\$, Fmt_b\$, Power_mode\$ and Level, respectively. |
| Lines 260 to 270 | Substitutes the limit of difference between test signal level and its monitor level (1%), and the maximum number of times to iterate a setting the oscillator level into the variables: Err_limit and Iteration (10 times), respectively.  |
| Lines 290 to 300 | Sets the adapter selection to Adapter\$ and then triggers a reset.   |
| Lines 310 to 350 | Sets the measurement parameter to Meas_para\$; the sweep type, Swp_type\$; the sweep start point, Start; the sweep stop point, Stop, respectively.   |
| Lines 390 to 400 | Enables bit 8 (calibration/compensation data measurement completion) in the instrument event status register to use an SRQ and sets bit 2 in the service request enable register to 1.   |
| Lines 410 to 440 | Uses the FNFixt_comp subprogram to measure open/short data. If an error is detected after each measurement, stops the program. For the FNFixt_comp subprogram, refer to the description in Example 4-3 on page 65.   |

- Lines 460 to 500 Turns on the manual sweep function and the level monitor function, and sets the oscillator level mode to Power\_mode\$.
- Lines 520 to 600 According to the oscillator level mode, substitutes the command name for reading the level monitor value, the range (lower limit and upper limit) of level setting into the variables: Command\$, Range\_l, and Range\_u, respectively.
- Lines 640 to 650 Prompts the user to connect a DUT, and waits for a press of the **[Enter]** key after the connection.
- Lines 670 to 700 Displays header for list of measurement results, and substitutes the format to display the measurement results into the variable: Img\$.
- Lines 720 Sets the measurement point.
- Lines 730 to 750 Sets the initial setting to control the oscillator level.
- Lines 760 to 880 Until the difference between the test signal level (target) and the monitor level is less than the variable: Err\_limit, iterates setting and monitoring, and updating the oscillator level. (maximum number of iteration times is the variable: Iteration.)
- Lines 890 to 970 Reads out the measurement results and displays them according to Img\$.
- Lines 990 to 1010 Sets the trace A display format to Fmt\_a\$, and then executes the auto scale on trace A to automatically set the scale parameters so that waveforms fit on the screen.
- Lines 1020 to 1040 Sets the trace B display format to Fmt\_b\$, and then executes the auto scale on trace B to automatically set the scale parameters so that waveforms fit on the screen.
- Lines 1060 to 1070 Prompts the user to determine whether to perform a measurement again. If the **[y]** key and the **[Enter]** key are pressed, returns to the DUT connection part (line 570).

**Example 13-5**

**Measurement controlling oscillator level**

```

10 DIM Adapter$(9), Meas_para$(9), Pow_mode$(9), Swp_type$(9)
20 DIM Fmt_a$(9), Fmt_b$(9), Buff$(9), Inp_char$(9), Img$(50)
30 REAL Start, Stop, Level, Data_a(1:2), Data_b(1:2)
40 REAL Err_limit, Range_l, Range_u
50 INTEGER Scode, Nop, Iteration, Result
60 CLEAR SCREEN
70 !
80 IF SYSTEM$("SYSTEM ID")="HP4294A" THEN
90   ASSIGN @Hp4294a TO 800
100   Scode=8
110 ELSE
120   ASSIGN @Hp4294a TO 717
130   Scode=7
140 END IF
150 !
160 Adapter$="OFF"
170 Meas_para$="IMPH"
180 Swp_type$="LOG"
190 Start=1.0E+3
200 Stop=1.0E+7
210 Nop=21
220 Fmt_a$="LOGY"

```

13. Application Sample Programs

## Application Sample Programs

### Measurement controlling oscillator level

```
230 Fmt_b$="LINY"
240 Pow_mode$="CURR"
250 Level=.001
260 Err_limit=1.0      ! Osc Level Error Limit: 1[%]
270 Iteration=10
280 !
290 OUTPUT @Hp4294a;"E4TP "&Adapter$
300 OUTPUT @Hp4294a;"PRES"
310 OUTPUT @Hp4294a;"MEAS "&Meas_para$
320 OUTPUT @Hp4294a;"SWPT "&Swp_type$
330 OUTPUT @Hp4294a;"STAR ";Start
340 OUTPUT @Hp4294a;"STOP ";Stop
350 OUTPUT @Hp4294a;"POIN ";Nop
360 !
370 ! Fixture Compensation (Open/Short)
380 !
390 OUTPUT @Hp4294a;"ESNB 256"
400 OUTPUT @Hp4294a;"*SRE 4"
410 Result=FNFixt_comp(@Hp4294a,Scode,"Open")
420 IF Result<>0 THEN Prog_end
430 Result=FNFixt_comp(@Hp4294a,Scode,"Short")
440 IF Result<>0 THEN Prog_end
450 !
460 OUTPUT @Hp4294a;"MANS ON"
470 OUTPUT @Hp4294a;"POWMOD ";Pow_mode$
480 OUTPUT @Hp4294a;"OMON ON"
490 OUTPUT @Hp4294a;"*OPC?"
500 ENTER @Hp4294a;Buff$
510 !
520 IF Pow_mode$="VOLT" THEN
530   Command$="OUTPVACP? "
540   Range_l=.005
550   Range_u=1.0
560 ELSE
570   Command$="OUTPIACP? "
580   Range_l=.0002
590   Range_u=.02
600 END IF
610 !
620 Meas_start: !
630 !
640 PRINT "Set DUT, then Push [Enter] key"
650 INPUT "",Inp_char$
660 !
670 PRINT ""
680 PRINT " ##### Measurement Result #####"
690 PRINT " Frequency Monitor: "&Pow_mode$"      Trace A      Trace B"
700 Img$="MD.5DE,2X,MD.4DE,4X,MD.4DE,X,MD.4DE"
710 FOR I=1 TO Nop
720   OUTPUT @Hp4294a;"MANP ";I
730   Set_lvl=Level
740   Count=0
750   Err=100.0
760   WHILE Count<Iteration AND ABS(Err)>Err_limit
770     OUTPUT @Hp4294a;"POWE ";Set_lvl
780     OUTPUT @Hp4294a;"SING"
790     OUTPUT @Hp4294a;"*OPC?"
800     ENTER @Hp4294a;Buff$
810     OUTPUT @Hp4294a;Command$I
820     ENTER @Hp4294a;Mon_lvl
830     Err=(Level-Mon_lvl)/Level*100
840     Set_lvl=Level*(Set_lvl/Mon_lvl)
850     IF Set_lvl<Range_l THEN Set_lvl=Range_l
860     IF Set_lvl>Range_u THEN Set_lvl=Range_u
```

```

870     Count=Count+1
880     END WHILE
890     OUTPUT @Hp4294a;"TRAC A"
900     OUTPUT @Hp4294a;"OUTPDTRCP? ";I
910     ENTER @Hp4294a;Data_a(1),Data_a(2)
920     OUTPUT @Hp4294a;"TRAC B"
930     OUTPUT @Hp4294a;"OUTPDTRCP? ";I
940     ENTER @Hp4294a;Data_b(1),Data_b(2)
950     OUTPUT @Hp4294a;"OUTPSWPRMP? ";I
960     ENTER @Hp4294a;Swp_para
970     PRINT USING Img$;Swp_para,Mon_lvl,Data_a(1),Data_b(1)
980     NEXT I
990     OUTPUT @Hp4294a;"TRAC A"
1000    OUTPUT @Hp4294a;"FMT "&Fmt_a$
1010    OUTPUT @Hp4294a;"AUTO"
1020    OUTPUT @Hp4294a;"TRAC B"
1030    OUTPUT @Hp4294a;"FMT "&Fmt_b$
1040    OUTPUT @Hp4294a;"AUTO"
1050    !
1060    INPUT "Once more? [Y]es/[N]o",Inp_char$
1070    IF UPC$(Inp_char$)="Y" OR UPC$(Inp_char$)="YES" THEN Meas_start
1080 Prog_end:!
1090    END
1100    !
1110    ! Fixture Compensation Data Measurement Function
1120    !
1130 DEF FNFixt_comp(@Hp4294a,INTEGER Scode,Standard$)
1140 DIM Inp_char$(9),Err_mes$(50)
1150 INTEGER Err_no
1160 OUTPUT @Hp4294a;"*CLS"
1170 PRINT "Set "&Standard$&"-Connection"
1180 INPUT "OK? [Y/N]",Inp_char$
1190 IF UPC$(Inp_char$)="Y" THEN
1200     ON INTR Scode GOTO Meas_end
1210     ENABLE INTR Scode;2
1220     SELECT Standard$
1230     CASE "Open"
1240         OUTPUT @Hp4294a;"COMA"
1250     CASE "Short"
1260         OUTPUT @Hp4294a;"COMB"
1270     CASE "Load"
1280         OUTPUT @Hp4294a;"COMC"
1290     END SELECT
1300     PRINT "Now measuring..."
1310 Meas_wait: GOTO Meas_wait
1320 Meas_end: !
1330     PRINT Standard$&" Data Measurement Complete"
1340     RETURN 0
1350 ELSE
1360     PRINT "Program Interruption"
1370     RETURN -1
1380 END IF
1390 FNEND

```

Application Sample Programs  
Measurement controlling oscillator level

Figure 13-6

An example of the output at the execution of the program in Example 13-5

```
##### Measurement Result #####  
Frequency      Monitor: CURR      Trace A      Trace B  
1.00000E+03    1.0051E-03        5.7868E-01   1.7915E+02  
1.58489E+03    1.0021E-03        5.7978E-01   1.7871E+02  
2.51189E+03    1.0014E-03        5.8124E-01   1.7816E+02  
3.98107E+03    9.9914E-04        5.8055E-01   1.7681E+02  
6.30957E+03    1.0075E-03        5.7941E-01   1.7607E+02  
1.00000E+04    9.9661E-04        5.8421E-01   1.7353E+02  
1.58489E+04    9.9532E-04        5.9138E-01   1.6945E+02  
2.51189E+04    9.9565E-04        6.0615E-01   1.6341E+02  
3.98107E+04    9.9705E-04        6.3609E-01   1.5481E+02  
6.30957E+04    9.9976E-04        7.1339E-01   1.4395E+02  
1.00000E+05    1.0039E-03        8.7667E-01   1.3063E+02  
1.58489E+05    9.9645E-04        1.2035E+00   1.1840E+02  
2.51189E+05    9.9707E-04        1.7492E+00   1.0860E+02  
3.98107E+05    9.9899E-04        2.6883E+00   1.0159E+02  
6.30957E+05    1.0027E-03        4.1729E+00   9.6967E+01  
1.00000E+06    9.9993E-04        6.5710E+00   9.4055E+01  
1.58489E+06    9.9788E-04        1.0369E+01   9.2241E+01  
2.51189E+06    1.0034E-03        1.6376E+01   9.1094E+01  
3.98107E+06    9.9963E-04        2.5871E+01   9.0381E+01  
6.30957E+06    1.0015E-03        4.0942E+01   8.9965E+01  
1.00000E+07    9.9141E-04        6.4823E+01   8.9751E+01
```



## Measurement using scanner

To perform measurement using the scanner while switching different channels, compensation for each channel must have been done. The 4294A lets you perform measurement while scanning channels, by making the connection as shown in 4294A and using functions including the list sweep, reading/writing compensation coefficients, and the manual sweep.

When performing measurement while scanning channels, you repeat the procedure "specifying a sweep segment using the manual sweep function → changing channels → measuring impedance." To make accurate measurement, you need to measure data for each channel and calculate its compensation coefficient.

To create the compensation coefficient for changing channels, execute the fixture compensation for each channel, read out compensation coefficients, and combine necessary part of them. An example is shown below.

Table 13-7 shows a schematic view of creating the scan-aware compensation coefficient. N+1 channels from 0 through N are used. Set the list sweep table so that the sweep condition for channel n corresponds to segment n+1. Execute the fixture compensation for channel 0 and read out the created compensation coefficient. The fixture compensation is performed for all segments; substitute the part of the read out compensation coefficient that corresponds to segment 1 into the part of the scan-aware compensation coefficient that corresponds to segment 1. For the other channels, perform the substitute operation from the fixture compensation to the scan-aware compensation coefficient. Finally, write the created compensation coefficient into the 4294A to bring the scan-aware compensation coefficient to take effect.

Figure 13-7

### Example of creating scan-aware compensation coefficient

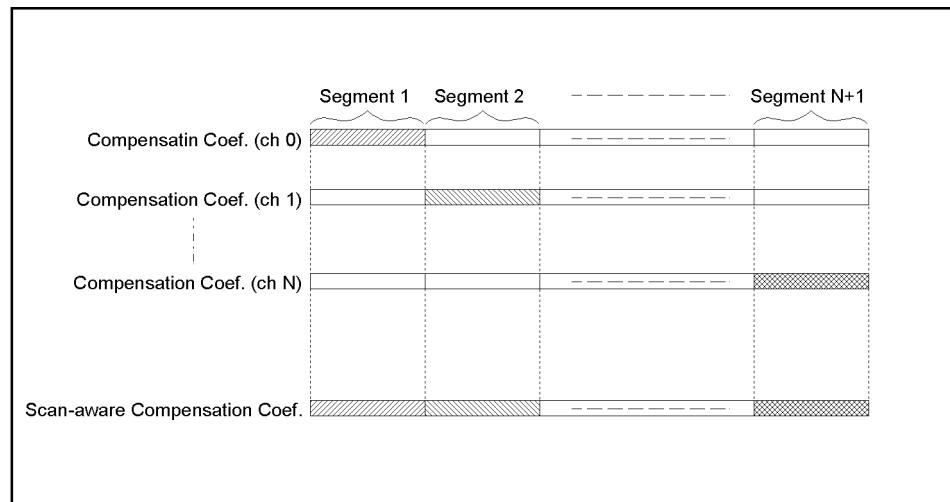

4294ape044

## Measurement procedure

This section describes how to perform measurement while scanning 4 channels, using the 4294A, the Agilent 3499A Switch/Control System, and two 44472A Dual 1×4 RF Multiplexer Modules.

Figure 13-8 shows the flow of measurement with scanning.

Figure 13-8

Scanning measurement flow

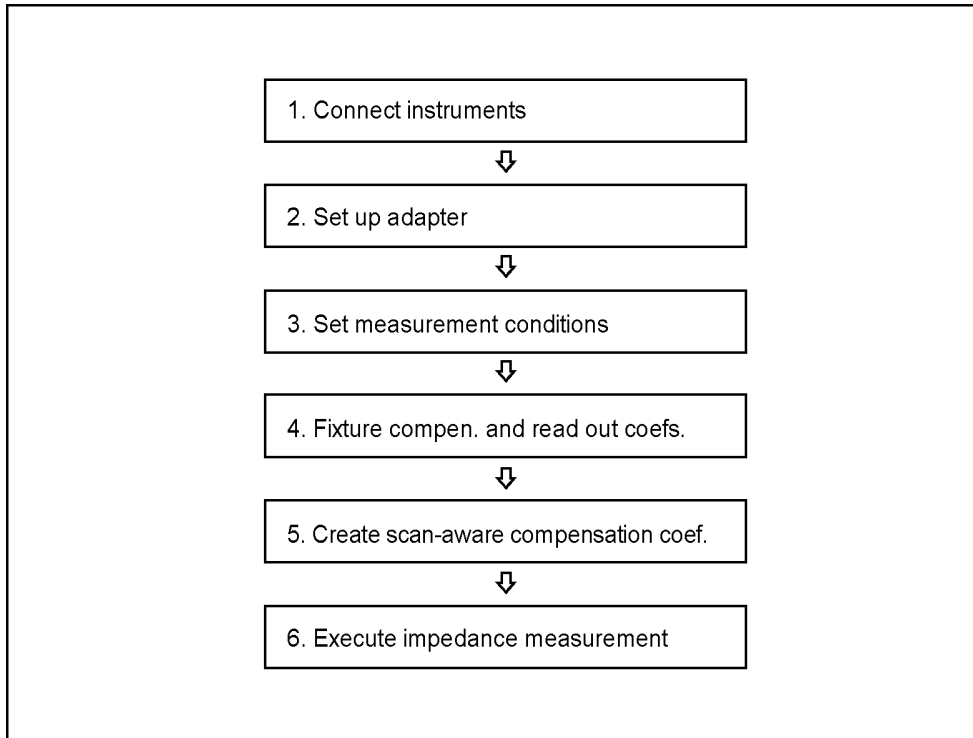

4294ape041

Step 1. Connecting the instruments

Connect the instruments as shown in Figure 13-9.

Figure 13-9

Connection between 4294A and 3499A

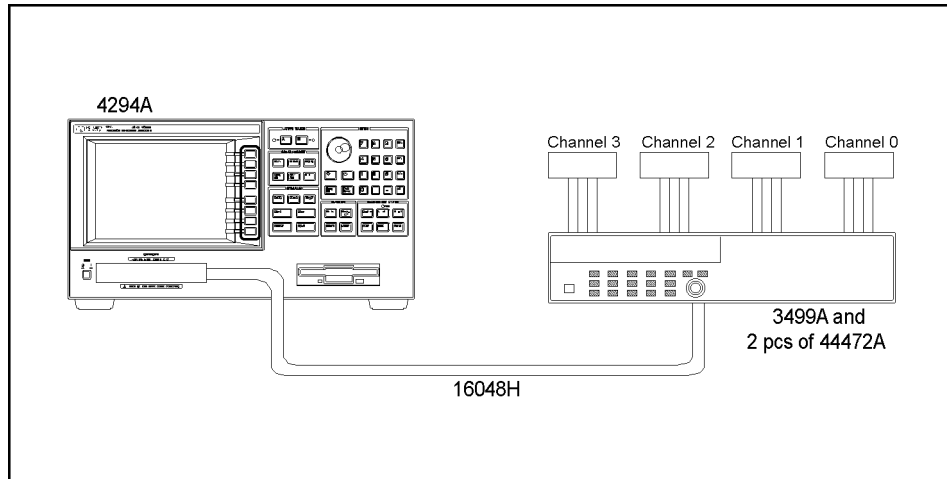

4294ape042

Step 2. Setting up the adapter

Select **4TP 2M** as the adapter and perform setup. Only the phase compensation is

performed here. Because the phase compensation is common to all the channels, perform it for one channel. For the phase compensation, you need to bring the measurement terminal into the open state as shown in Figure 13-10.

Figure 13-10

**Open state**

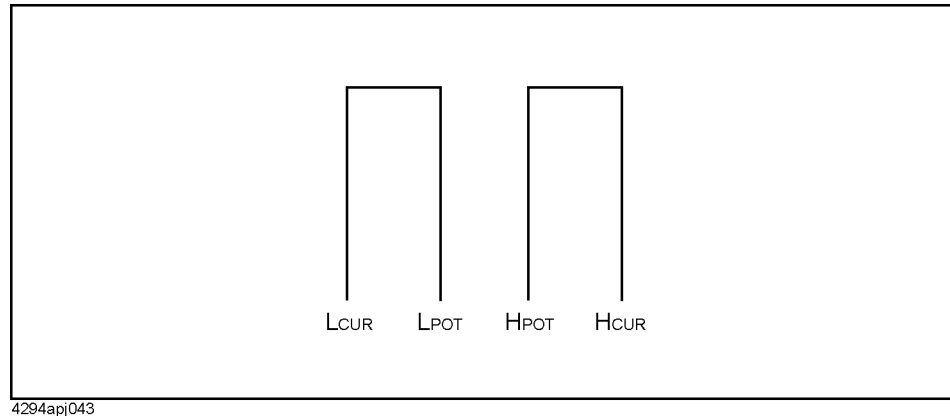

**Step 3.** Setting the measurement conditions

Set the list sweep table. Set the sweep condition for each channel for each segment. In this sample program, the sweep conditions from channels 0 through 3 are assigned to segments 1 through 4.

**Step 4.** Reading out the compensation coefficient of the fixture compensation

For each channel, perform the open, short and load fixture compensations. For the load compensation, use a working standard whose value is known. Data measurement for the compensation coefficient is performed for all segments. After calculating the compensation coefficient, read out the compensation coefficient for each channel.

**Step 5.** Creating the scan-aware compensation coefficient

From the compensation coefficient array read out in Step 4, combine the segments that correspond to individual channels to create the scan-aware compensation coefficient.

**Step 6.** Executing impedance measurement

Change the sweep range of the manual sweep and the channels and perform impedance measurement for the multiple channels.

**Sample program**

Example 13-6 shows a sample measurement program assuming that it is used in a scanning system (4 channels). This program is stored in the sample program disk as scan.bas.

- Lines 70 to 170 Identifies the external controller and Instrument BASIC and sets the GPIB address and select code.
- Lines 200 to 230 Prepares data for the list sweep table using DATA statements. Segments correspond to channels 0 to 3 from the top.
- Lines 250 to 300 Assigns the measurement conditions (adapter setting: 2-m test lead, measurement parameter: |Z|-q, sweep type: LIST, oscillator power level setting unit: VOLT, and DC bias setting unit: VOLT) into the

## Application Sample Programs

### Measurement using scanner

	variables Adapter\$, Meas_para\$, Swp_type\$, Pow_mod\$, and Dc_mod\$, respectively.
Lines 340 to 370	Performs setting the 3499A. Make setting so that the system mode is 3488A mode, modules 1 and 2 are coupled, and channel 0 is closed.
Lines 410 to 450	Performs setting to set up the adapter. After preset, in order to use SRQ, enables the instrument event status register's bit 8 (calibration/compensation data measurement completion) and sets the service request enable register's bit 2 to 1.
Lines 460 to 500	Displays the message to prompt the user to bring channel 0 to the open state and then, using the subprogram FNSetup_4tp, measures the phase compensation data. The subprogram FNSetup_4tp will be described later.
Lines 540 to 560	Sets the measurement parameter to Meas_para\$, the oscillator power level setting unit to Pow_mod\$, and the DC bias setting unit to Dc_mod\$, respectively.
Lines 570 to 740	Reads data from the DATA statements and creates the list sweep table. In this block, enters the position of the measurement point at the end of each segment to Point (n). Enters 0 to Point(0) to use it later for creating the compensation coefficient and setting the manual sweep range. After creating the list sweep table, sets the sweep mode to the list sweep.
Lines 780 to 790	Defines the compensation coefficient array variables: Open, Short, Load, and Temp. Temp is used temporarily to store the compensation coefficient read out from the 4294A. Because the compensation coefficient is a complex number, the array size is 2 times the total number of measurement points.
Lines 800 to 810	Sets the readout format for compensation coefficient to IEEE64-bit. Then, makes setting so that the measurement points at which the compensation data is measured are the points that the user has specified.
Line 850	Sets the switches of the 3499A to scan the channel.
Lines 860 to 880	Displays the connected channel and, using the subprogram FNFixt_comp, measures the open data. For information on the subprogram FNFixt_comp, see the description in Example 4-3 on page 65.
Lines 890 to 920	Reads out the open compensation coefficient calculated from the measurement data from the 4294A and enters it to the variable Temp.
Lines 930 to 960	Enters the sweep range for the channel from the variable Temp to Open. In this sample, the segment number for a channel is larger than the channel number by 1. For example, the sweep range for channel 0 is the sweep range of segment 1.
Lines 1000 to 1150	Performs the short compensation in the same way as the open compensation and creates the multiple channel support compensation coefficient.
Lines 1180 to 1190	Enters the load values used for the load compensation. In this sample, R:100 $\Omega$ and L:0 nH are set.

- Lines 1200 to 1340 Performs the load compensation in the same way as the open compensation and creates the multiple channel support compensation coefficient.
- Lines 1380 to 1430 Enters the created compensation coefficient to the 4294A.
- Lines 1470 to 1480 Sets the trigger source to the internal trigger and stops the sweep.
- Lines 1520 to 1530 In order to use SRQ, enables the instrument event status register's bit 1 (sweep completion) and sets the service request enable register's bit 2 to 1.
- Lines 1590 to 1670 Starts the impedance measurement. Displays the message to prompt the user to connect DUTs to all channels.
- Line 1680 Enables the manual sweep function.
- Lines 1700 to 1710 Changes the switches of the 3499A to change the channel. A wait time is provided so that measurement does not start before switching is complete.
- Lines 1720 to 1760 Enables service request interrupts.
- Lines 1770 to 1780 Sets the manual sweep range and performs a sweep.
- Lines 1920 to 2200 The subprogram to perform the fixture compensation. For more information, see the description in Example 4-3 on page 65.
- Lines 2240 to 2500 The subprogram to set up the 4-terminal pair cable. Its details are as follows.
- Line 2220  
Clears the status byte register and the instrument event status register.
- Lines 2230 to 2240  
Displays the message that prompts the user to make connection for the measurement specified with Standart\$ and waits for pressing the y key and the return key after the connection.
- Lines 2260 to 2270  
Sets the branch destination in response to SRQ interrupts and enables SRQ interrupts.
- Lines 2290 to 2340  
Sends the command to execute the measurement of the standard specified with Standard\$.
- Line 2350  
Waits for completion of the measurement.
- Lines 2370 to 2380  
Displays the message indicating completion of the measurement and returns 0 as the return value from the subprogram.
- Lines 2400 to 2410  
The processing when a key other than the y key is pressed. Returns -1 as the return value form the subprogram.

Example 13-6

Measurement with channel switching (scanning)

```
10 DIM Adapter$[9],Meas_para$[5],Swp_type$[9]
20 DIM Fmt_a$[9],Fmt_b$[9],Start$[9],Stop$[9],Nop$[5],Osc$[9]
30 DIM Bias$[9],Bw$[5],Avg$[5],Header$[9],Buff$[9]
40 INTEGER Max_chan,Point(4),Scode,I,J,Opc
50 CLEAR SCREEN
60 !
70 IF SYSTEM$("SYSTEM ID")="HP4294A" THEN
80     ASSIGN @Agt4294a TO 800
90     ASSIGN @Binary TO 800;FORMAT OFF
100    ASSIGN @Agt3499a TO 809
110    Scode=8
120 ELSE
130     ASSIGN @Agt4294a TO 717
140     ASSIGN @Binary TO 717;FORMAT OFF
150     ASSIGN @Agt3499a TO 709
160     Scode=7
170 END IF
180 !
190 !      Start      Stop      NOP      OSC      BIAS  BW      AVG
200 DATA "100KHZ" , "200KHZ" , "21" , "0.5" , "0" , "2" , "1"
210 DATA "100KHZ" , "200KHZ" , "21" , "0.5" , "0" , "2" , "1"
220 DATA "100KHZ" , "500KHZ" , "81" , "0.5" , "0" , "2" , "1"
230 DATA "500KHZ" , "600KHZ" , "21" , "0.5" , "0" , "2" , "1"
240 !
250 Max_chan=3
260 Adapter$="M2"
270 Meas_para$="IMPH"
280 Swp_type$="LIST"
290 Pow_mod$="VOLT"
300 Dc_mod$="VOLT"
310 !
320 ! 3499A Setting
330 !
340 OUTPUT @Agt3499a;"SYSMODE HP3488A"
350 OUTPUT @Agt3499a;"RESET"
360 OUTPUT @Agt3499a;"CPAIR 1,2"
370 OUTPUT @Agt3499a;"CLOSE 100,110"
380 !
390 ! Adapter Setup
400 !
410 CLEAR SCREEN
420 OUTPUT @Agt4294a;"PRES"
430 OUTPUT @Agt4294a;"ESNB 256"
440 OUTPUT @Agt4294a;"*SRE 4"
450 OUTPUT @Agt4294a;"E4TP "&Adapter$
460 PRINT "##### Adapter Setup #####"
470 PRINT "Channel 0 is activated."
480 Result=FNSetup_4tp(@Agt4294a,Scode,"Open")
490 IF Result<>0 THEN Prog_end
500 OUTPUT @Agt4294a;"ECALDON"
510 !
520 ! 4294A Setting
530 !
540 OUTPUT @Agt4294a;"MEAS "&Meas_para$
550 OUTPUT @Agt4294a;"POWMOD "&Pow_mod$
560 OUTPUT @Agt4294a;"DCMOD "&Dc_mod$
```

```

570 OUTPUT @Agt4294a;"EDITLIST"
580 Point(0)=0
590 FOR I=0 TO Max_chan
600   READ Start$,Stop$,Nop$,Osc$,Bias$,Bw$,Avg$
610   Point(I+1)=Point(I)+IVAL(Nop$,10)
620   OUTPUT @Agt4294a;"SADD"
630   OUTPUT @Agt4294a;"MEAS "&Meas_para$
640   OUTPUT @Agt4294a;"STAR "&Start$
650   OUTPUT @Agt4294a;"STOP "&Stop$
660   OUTPUT @Agt4294a;"POIN "&Nop$
670   OUTPUT @Agt4294a;"BWFACT "&Bw$
680   OUTPUT @Agt4294a;"POWE "&Osc$
690   OUTPUT @Agt4294a;"DCV "&Bias$
700   OUTPUT @Agt4294a;"PAVERFACT "&Avg$
710   OUTPUT @Agt4294a;"SDON"
720 NEXT I
730 OUTPUT @Agt4294a;"EDITDONE"
740 OUTPUT @Agt4294a;"SWPT "&Swp_type$
750 !
760 ! Compensation
770 !
780 ALLOCATE
Open(1:Point(Max_chan+1),1:2),Short(1:Point(Max_chan+1),1:2)
790 ALLOCATE
Load(1:Point(Max_chan+1),1:2),Temp(1:Point(Max_chan+1),1:2)
800 OUTPUT @Agt4294a;"FORM3"
810 OUTPUT @Agt4294a;"CALP USER"
820 CLEAR SCREEN
830 PRINT "##### Open Compensation #####"
840 FOR I=0 TO Max_chan
850   OUTPUT @Agt3499a;"CLOSE 10"&VAL$(I)&","11"&VAL$(I)
860   PRINT "Channel "&VAL$(I)&" is activated."
870   Result=FNFixt_comp(@Agt4294a,Scode,"Open")
880   IF Result<>0 THEN Prog_end
890   OUTPUT @Agt4294a;"OUTPCOMC1?"
900   ENTER @Agt4294a USING "#,8A";Header$
910   ENTER @Binary;Temp(*)
920   ENTER @Agt4294a USING "#,1A";Buff$
930   FOR J=Point(I)+1 TO Point(I+1)
940     Open(J,1)=Temp(J,1)
950     Open(J,2)=Temp(J,2)
960   NEXT J
970   PRINT
980 NEXT I
990 CLEAR SCREEN
1000 PRINT "##### Short Compensation #####"
1010 FOR I=0 TO Max_chan
1020   OUTPUT @Agt3499a;"CLOSE 10"&VAL$(I)&","11"&VAL$(I)
1030   PRINT "Channel "&VAL$(I)&" is activated."
1040   Result=FNFixt_comp(@Agt4294a,Scode,"Short")
1050   IF Result<>0 THEN Prog_end
1060   OUTPUT @Agt4294a;"OUTPCOMC2?"
1070   ENTER @Agt4294a USING "#,8A";Header$
1080   ENTER @Binary;Temp(*)
1090   ENTER @Agt4294a USING "#,1A";Buff$
1100   FOR J=Point(I)+1 TO Point(I+1)
1110     Short(J,1)=Temp(J,1)
1120     Short(J,2)=Temp(J,2)

```

## Application Sample Programs

### Measurement using scanner

```
1130     NEXT J
1140     PRINT
1150  NEXT I
1160  CLEAR SCREEN
1170  PRINT "##### Load Compensation #####"
1180  OUTPUT @Agt4294a;"DCOMLOADR 100OHM"
1190  OUTPUT @Agt4294a;"DCOMLOADL 0H"
1200  FOR I=0 TO Max_chan
1210     OUTPUT @Agt3499a;"CLOSE 10"&VAL$(I) & ",11"&VAL$(I)
1220     PRINT "Channel "&VAL$(I) & " is activated."
1230     Result=FNFixt_comp(@Agt4294a,Scode,"Load")
1240     IF Result<>0 THEN Prog_end
1250     OUTPUT @Agt4294a;"OUTPCOMC3?"
1260     ENTER @Agt4294a USING "#,8A";Header$
1270     ENTER @Binary;Temp(*)
1280     ENTER @Agt4294a USING "#,1A";Buff$
1290     FOR J=Point(I)+1 TO Point(I+1)
1300         Load(J,1)=Temp(J,1)
1310         Load(J,2)=Temp(J,2)
1320     NEXT J
1330     PRINT
1340  NEXT I
1350  !
1360  ! Make new compensation coefficients
1370  !
1380  OUTPUT @Agt4294a;"INPUCOMC1 "&Header$;
1390  OUTPUT @Binary;Open(*),END
1400  OUTPUT @Agt4294a;"INPUCOMC2 "&Header$;
1410  OUTPUT @Binary;Short(*),END
1420  OUTPUT @Agt4294a;"INPUCOMC3 "&Header$;
1430  OUTPUT @Binary;Load(*),END
1440  !
1450  ! Trigger Setting
1460  !
1470  OUTPUT @Agt4294a;"TRGS INT"
1480  OUTPUT @Agt4294a;"HOLD"
1490  !
1500  ! SRQ Setting
1510  !
1520  OUTPUT @Agt4294a;"ESNB 1"
1530  OUTPUT @Agt4294a;"*SRE 4"
1540  !
1550  ! Measuring DUT
1560  !
1570  CLEAR SCREEN
1580  PRINT "##### DUT Measurement #####"
1590  ON ERROR GOTO Dut_meas_start
1600  Dut_meas_start
1610  PRINT "Set DUTs for All Channels."
1620  INPUT "OK? [Y/N]",Buff$
1630  OFF ERROR
1640  IF UPC$(Buff$)<>"Y" THEN
1650     PRINT "Program Interruption"
1660     GOTO Prog_end
1670  END IF
1680  OUTPUT @Agt4294a;"MANS ON"
1690  FOR I=0 TO Max_chan
1700     OUTPUT @Agt3499a;"CLOSE 10"&VAL$(I) & ",11"&VAL$(I)
```



```

1710     WAIT .2
1720     OUTPUT @Agt4294a;"*CLS"
1730     OUTPUT @Agt4294a;"*OPC?"
1740     ENTER @Agt4294a;Opc
1750     ON INTR 7 GOTO Sweep_end
1760     ENABLE INTR 7;2
1770     OUTPUT @Agt4294a;"MANR
"&VAL$(Point(I)+1)&","&VAL$(Point(I+1))
1780     OUTPUT @Agt4294a;"SING"
1790     PRINT "Measuring Channel ";VAL$(I)
1800 Sweep_wait: GOTO Sweep_wait
1810 Sweep_end: OFF INTR 7
1820     NEXT I
1830     OUTPUT @Agt3499a;"RESET"
1840     !
1850     PRINT "Measurement Completed"
1860     !
1870 Prog_end: !
1880     END
1890     !
1900     ! Fixture Compensation Data Measurement Function
1910     !
1920     DEF FNFixt_comp(@Agt4294a,INTEGER Scode,Standard$)
1930         DIM Inp_char$(9)
1940         OUTPUT @Agt4294a;"*CLS"
1950         ON ERROR GOTO Compen_start
1960 Compen_start: !
1970         PRINT "Set "&Standard$&"-Connection"
1980         INPUT "OK? [Y/N]",Inp_char$
1990         OFF ERROR
2000         IF UPC$(Inp_char$)="Y" THEN
2010             ON INTR Scode GOTO Meas_end
2020             ENABLE INTR Scode;2
2030             SELECT Standard$
2040                 CASE "Open"
2050                     OUTPUT @Agt4294a;"COMA"
2060                 CASE "Short"
2070                     OUTPUT @Agt4294a;"COMB"
2080                 CASE "Load"
2090                     OUTPUT @Agt4294a;"COMC"
2100             END SELECT
2110             PRINT "Now measuring..."
2120 Meas_wait: GOTO Meas_wait
2130 Meas_end: !
2140             PRINT Standard$&" Data Measurement Complete"
2150             RETURN 0
2160         ELSE
2170             PRINT "Program Interruption"
2180             RETURN -1
2190         END IF
2200     FNEND
2210     !
2220     ! 4TP Setup Function
2230     !
2240     DEF FNSetup_4tp(@Agt4294a,INTEGER Scode,Standard$)
2250         DIM Inp_char$(9)
2260         OUTPUT @Agt4294a;"*CLS"
2270         ON ERROR GOTO Setup_start

```

## Application Sample Programs

### Measurement using scanner

```
2280 Setup_start:  !
2290     PRINT "Set "&Standard$&"-Connection"
2300     INPUT "OK? [Y/N]",Inp_char$
2310     OFF ERROR
2320     IF UPC$(Inp_char$)="Y" THEN
2330         ON INTR Scode GOTO Meas_end
2340         ENABLE INTR Scode;2
2350         PRINT "Now measuring..."
2360         SELECT Standard$
2370             CASE "Open"
2380                 OUTPUT @Agt4294a;"ECALP"
2390             CASE "Load"
2400                 OUTPUT @Agt4294a;"ECALC"
2410         END SELECT
2420 Meas_wait: GOTO Meas_wait
2430 Meas_end: !
2440     PRINT Standard$&" Data Measurement Complete"
2450     RETURN 0
2460 ELSE
2470     PRINT "Program Interruption"
2480     RETURN -1
2490 END IF
2500 FNEND
```

---

## 14 Using Printer

This chapter describes the procedures for printing out your measurement results with a printer.

---

## Printing onto a Printer Directly Connected to Agilent 4294A

The Agilent 4294A provides direct connection to a printer, allowing you to print a hardcopy of the LCD screen.

The printer can be connected to the printer parallel port on the rear panel of the 4294A. See *Operation Manual* for detailed information on the connection and supported printers.

### Setting images to be printed

Besides traces, the following items can be displayed on the LCD for printing.

Items	Command
Sweep and measurement parameters for all measurement points	“LISV” on page 330
Current parameter values for setting of the instrument	“OPEP” on page 354
Setting values set for a user-defined calibration kit	“CAL S” on page 267
Setting values for a fixture compensation standard	“COM S” on page 273
List sweep table	“DISL” on page 289
Limit line table	“DISLLIST” on page 289

Use the command below to restore the normal screen display from the screen with the above items.

- “RES D” on page 399

## How to print screen

Set the LCD screen as you desired then use the command below to start printing.

- “PRINALL” on page 394

Use the command below to abort your printing.

- “COPA” on page 274

The following items can be set for the printing.

Item	Command	Initial settings [Unit]
Printing resolution (DPI)	“DPI” on page 298	75 [DPI]
Form feed	“FORMFEED” on page 307	Yes
Media orientation (Portrait/Landscape)	“LANDSCAPE” on page 313	Portrait
Left margin	“LMARG” on page 331	1 [inch]
Top margin	“TMARG” on page 442	1 [inch]
Softkey labels	“PRSOFT” on page 394	Not printed
Time and date	“COPT” on page 275	Not printed
Colors	“PRIC” on page 394	Black and white

Settings for the above items are stored in the non-volatile memory (SRAM), thus they do not revert to the initial settings by executing “PRES” command on page 393. Use the command below to restore the initial settings.

- “DFLT” on page 287

---

## Printing onto a Printer Available on an External Computer

The 4294A can be connect to LAN (Local Area Network).

---

**NOTE**

When a printer is directly connected to LAN (not a computer connected to LAN), it is not possible to print onto the computer from the 4294A connected to LAN.

From the 4294A connected to LAN, images on the LCD or files on the 4294A can be transferred to other computers connected to the same LAN. This means that printing onto a printer connected to an external computer can be achieved by first transferring an image to the computer then using the computer to print the image onto the printer.

---

**NOTE**

When transferring a TIFF format file for printing, an appropriate application for processing the format must be installed on an external computer.

For example, follow the steps below to print an image on the LCD of the 4294A.

- Step 1.** Set the LCD screen so that a desired image for printing is displayed.
- Step 2.** Transfer a file named “screen.tif” on the dynamic data disk (a disk used for transferring internal data in the 4294A via LAN) to an external computer.
- Step 3.** Use the computer to print “screen.tif.”
- Step 4.** Remove “screen.tif” if it is no longer necessary.

---

**NOTE**

See Chapter 12 , “Using LAN,” for connection to LAN and transferring files via LAN.

---

---

# 15

## Setting the Display (LCD)

This chapter describes the procedures for setting the displayed colors of traces and characters as well as the brightness of the LCD display.

## Setting the LCD Screen

### Setting colors for images on the LCD screen

Colors can be separately specified for the following images on the LCD screen.

- Trace A (data trace type)
- Trace A (memory trace type)
- Trace B (data trace type)
- Trace B (memory trace type)
- Grid and part of softkey labels
- Text strings for warning notification
- Text strings other than measurement values and warning notification
- Text strings for Instrument BASIC.
- Pen 1 strings for Instrument BASIC.
- Pen 2 strings for Instrument BASIC.
- Pen 3 strings for Instrument BASIC.
- Pen 4 strings for Instrument BASIC.
- Pen 5 strings for Instrument BASIC.
- Pen 6 strings for Instrument BASIC.

---

**NOTE**

When performing list sweep, one of the colors for the Instrument BASIC pens 1 to 6 will be assigned to a trace of each segment.

Use the command below to select an item for setting out of those listed above.

- “COLO” on page 272

Use the commands below to assign a color to the selected item with the above command.

- “CBRI” on page 268
- “COLOR” on page 273
- “TINT” on page 441

### Setting overall condition for the LCD screen

Use the command below to specify brightness of the LCD screen.

- “INTE” on page 311

Use the command below to specify brightness of the background of the LCD screen.

- “BACI” on page 262

### Restoring factory setting

Use the command below to restore the factory settings for coloring all of the items on the screen.

- “DEFC” on page 285

Use the command below to restore the factory setting for coloring of the item selected with “COLO” command.

- “RSCO” on page 401



---

## Sample program for setting the LCD screen

Example 15-1 shows a sample program for setting colors for the LCD screen. This program is saved in the file “color.bas” on the sample program disk.

This program allows you to change the color of the data trace A to green and to increase the whiteness of colors for the pens 2 to 6 in the Instrument BASIC screen.

- Lines 20 to 60      Identifies the external controller and Instrument BASIC and sets the GPIB address and the select code.
- Lines 80 to 90      Substitutes hue of the data trace A and chroma of the pens 2 to 6 in the Instrument BASIC screen to the variables Trc\_a\_tint and Pen\_clr, respectively.
- Lines 110 to 120    Sets the hue of the data trace A to Trc\_a\_tint.
- Lines 130 to 160    Sets the chroma of the pens 2 to 6 in the Instrument BASIC screen to Pen\_clr.

### Example 15-1      Setting Colors in the LCD Screen

```
10     INTEGER Trc_a_tint, Pen_clr
20     IF SYSTEM$("SYSTEM ID")="HP4294A" THEN
30         ASSIGN @Hp4294a TO 800
40     ELSE
50         ASSIGN @Hp4294a TO 717
60     END IF
70     !
80     Trc_a_tint=33
90     Pen_clr=50
100    !
110    OUTPUT @Hp4294a;"COLO TRAD"
120    OUTPUT @Hp4294a;"TINT ";Trc_a_tint
130    FOR I=2 TO 6
140         OUTPUT @Hp4294a;"COLO PEN"&VAL$(I)
150         OUTPUT @Hp4294a;"COLOR ";Pen_clr
160    NEXT I
170    END
```

Setting the Display (LCD)

**Sample program for setting the LCD screen**

---

# 16

## GPIB Command Reference

This chapter is the GPIB command reference for the Agilent 4294A. The IEEE common commands, the 4294A commands, and the Instrument BASIC control commands are described in alphabetical order.

## Notational conventions in this command reference

This section describes the rules to read the description of the commands in this chapter.

### Syntax

Part with heading “Syntax” describes the syntax to send a command from the external controller to the 4294A. A syntax consists of a command part and a parameter part. The separator between the command part and the parameter part is a space.

If there are several parameters, the separator between adjacent parameters is a comma (,). 2 points (..) between commas indicate that parameters in that part are omitted. For example, <numeric1>,...,<numeric4> indicates that 4 parameters, <numeric1>,<numeric2>,<numeric3>,<numeric4>, are required. String-type parameters, <string>, <string 1>, and so on, must be enclosed in double quotation marks (").

You can omit any lowercase letters in syntax. For example, “:PROG:CATalog?” on page 451 can be shortened as “:PROG:CAT?”.

The definition of symbols used in the syntax is as follows:

- ◇ Characters enclosed in this pair of symbols are necessary parameters when sending the command.
- [] Part enclosed in this parenthesis pair can be omitted.
- { } Part enclosed in this parenthesis pair indicates that you must select one of the items in this part. Individual items are separated by pipes (|).

### Description

Part with heading “Description” describes how to use the command or the operation when executed.

### Parameters

Part with heading “Parameters” describes necessary parameters when sending the command. When a parameter is a value type or a string type enclosed with <>, its description, allowable setting range, initial value, and so on are given; when a parameter is a selection type enclosed with { }, the description of each selection item is given.

### Query response

Part with heading “Query response” describes the data format read out when query (reading out data) is available with this command.

Each readout parameter is enclosed with { }. If there are several items within { } separated by the pipe (|), only one of them is read out.

When several parameters are read out, they are separated with a comma (,). Note that, 2 points (..) between commas indicate that the data of that part is omitted. For example, {numeric1},...,{numeric4} indicates that 4 data items, {numeric1}, {numeric2}, {numeric3}, and {numeric4}, are read out.

<newline><^END> after the parameters is the program message terminator.

### **Corresponding key**

Part with heading “Corresponding key” shows the operational procedure of the front panel keys that has the same effect as this command.

---

## IEEE common command

This section describes the IEEE common commands.

### **\*CLS**

**Syntax**

\*CLS

**Description**

Clears the error queue, Status Byte Register, Operation Status Register, Standard Event Status Register, and Instrument Event Status Register. This command has the same function as the “CLES” command on page 271. (No query)

**Corresponding key**

No front panel key is available to execute this function.

### **\*ESE**

**Syntax**

\*ESE <numeric>

\*ESE?

**Description**

Sets the value of the Standard Event Status Enable Register.

**Parameters**

	<b>&lt;numeric&gt;</b>
Description	Setting value of the register
Range	0 to 255
Initial value	0
Resolution	1

If the specified parameter is out of the allowable setting range, the minimum value (if the lower limit of the range is not reached) or the maximum value (if the upper limit of the range is exceeded) is set.

**Query response**

{numeric}<newline><^END>

**Corresponding key**

No front panel key is available to execute this function.

**\*ESR?**

<b>Syntax</b>	*ESR?
<b>Description</b>	Reads out the value of the Standard Event Status Register. Executing this command clears the register value. (Query only)
<b>Query response</b>	{numeric}<newline><^END>
<b>Corresponding key</b>	No front panel key is available to execute this function.

**\*IDN?**

<b>Syntax</b>	*IDN?
<b>Description</b>	Reads out the manufacturer, model number, serial number, and firmware version number of the 4294A. (Query only)
<b>Query response</b>	{string 1},{string 2},{string 3},{string 4}<newline><^END> Readout data is as follows: {string 1}           Manufacturer. HEWLETT-PACKARD is always read out. {string 2}           Model number. 4294A is always read out. {string 3}           10-digit serial number (example: JP1KF00101). {string 4}           Firmware version number (example: 01.00).
<b>Corresponding key</b>	No front panel key is available to execute this function.

**\*OPC**

<b>Syntax</b>	*OPC
<b>Description</b>	Makes the setting, when the execution of all overlap commands (refer to “*WAI” on page 254) is completed, to set the OPC bit (bit 0) of the Standard Event Status Register. (No query)
<b>Corresponding key</b>	No front panel key is available to execute this function.

**\*OPC?**

<b>Syntax</b>	*OPC?
<b>Description</b>	Reads out 1 when the execution of all overlap commands (refer to “*WAI” on page 254) is completed. (Query only)
<b>Query response</b>	{1}<newline><^END>
<b>Corresponding key</b>	No front panel key is available to execute this function.

**\*OPT?**

**\*OPT?**

**Syntax** \*OPT?

**Description** Reads out the identification number of an option installed in the 4294A. (Query only)

**Query response** {string}<newline><^END>  
If there is no installed option, a blank ("") is read out.

**Corresponding key** No front panel key is available to execute this function.

**\*RST**

**Syntax** \*RST

**Description** Triggers a reset to the preset state. Although this preset state is almost the same as that of the reset result with the “PRES” command on page 393, there are some differences as follows. (No query)

- The sweep mode is set to HOLD.
- The HP Instrument BASIC is reset.

**Corresponding key** No front panel key is available to execute this function.

**\*SRE**

**Syntax** \*SRE <numeric>  
\*SRE?

**Description** Sets the value of the Service Request Enable Register.

**Parameters**

	<b>&lt;numeric&gt;</b>
Description	Setting value of the register
Range	0 to 255
Initial value	0
Resolution	1

If the specified parameter is out of the allowable setting range, the minimum value (if the lower limit of the range is not reached) or the maximum value (if the upper limit of the range is exceeded) is set.

**Query response** {numeric}<newline><^END>

**Corresponding key** No front panel key is available to execute this function.



**\*STB?**

**Syntax** \*STB?

**Description** Reads out the value of the Status Byte Register. (Query only)

**Query response** {numeric}<newline><^END>

**Corresponding key** No front panel key is available to execute this function.

**\*TRG**

**Syntax** \*TRG

**Description** If the trigger mode is set to GPIB/LAN (set to BUS with the “TRGS” command on page 446), triggers the 4294A waiting for a trigger. (No query)

**Corresponding key** No front panel key is available to execute this function.

**\*TST?**

**Syntax** \*TST?

**Description** Executes the self-test and reads out the result. (Query only)

**Query response** {1|0}<newline><^END>

	Description
1	The result of the self-test is FAIL.
0	The result of the self-test is PASS.

**Corresponding key** No front panel key is available to execute this function.

**\*WAI**

**\*WAI**

**Syntax**

\*WAI

**Description**

Waits for the execution of all overlap commands sent before this command to be completed. Overlap commands include the following. (No query)

- Commands the execution of which finishes when configuration parameters are transferred to the DSP:

“AVER” on page 261	“AVERREST” on page 261
“BWFACT” on page 266	“CALDON” on page 266
“CALQUI” on page 267	“CALP” on page 267
“CALST” on page 268	“CENT” on page 269
“COMST{A B C}” on page 274	“CWFREQ” on page 276
“DCI” on page 281	“DCMOD” on page 281
“DCO” on page 282	“ECALDON” on page 299
“EDITDONE” on page 300	“MAXDCV” on page 336
“MINDCV” on page 339	“MKRCENT” on page 340
“MKRSPAN” on page 341	“MKRSTAR” on page 348
“MKRSTOP” on page 348	“MKRZM” on page 350
“PDEL” on page 386	“PEAKCENT” on page 387
“POIN” on page 390	“PORE” on page 390
“PORTL” on page 391	“PORTZ” on page 391
“POWE” on page 392	“POWMOD” on page 393
“PRES” on page 393	“RECD” on page 395
“SDEL” on page 413	“SPAN” on page 429
“STAR” on page 431	“STOP” on page 433
“SWED” on page 435	“SWET” on page 435
“SWPP” on page 436	“SWPT” on page 436

- Commands the execution of which finishes when the sweep finishes:

“CAL{A B C}” on page 266	“COM{A B C}” on page 273
“ECAL{P A B C}” on page 299	“NUMG” on page 353
“SING” on page 424	

**Corresponding key**

No front panel key is available to execute this function.

## The Agilent 4294A commands

This section describes the GPIB commands specific to the 4294A.

### ACCUD

**Syntax** ACCUD {ON|OFF|1|0}  
 ACCUD?

**Description** Enables/disables the display mode to accumulate traces in which they are not cleared at each sweep.

**Parameters**

	Description
ON or 1	Enables the trace accumulating display.
OFF or 0 (Initial value)	Disables the trace accumulating display (the trace is cleared at each sweep and only the latest trace is displayed).

**Query response** {1|0}<newline><^END>

**Corresponding key** [Display] - ACCUMULATE on OFF

### ADDRCONT

**Syntax** ADDRCONT <numeric>  
 ADDRCONT?

**Description** Sets the GPIB address of the controller of the 4294A.

**Parameters**

	<numeric>
Description	GPIB address of the controller
Range	1 to 30
Initial value	21
Resolution	1

If the specified parameter is out of the allowable setting range, the minimum value (if the lower limit of the range is not reached) or the maximum value (if the upper limit of the range is exceeded) is set.

**Query response** {numeric}<newline><^END>

**Corresponding key** [Local] - ADDRESS: CONTROLLER

## **ADDRGW**

**Syntax**            ADDRGW <1st>,<2nd>,<3rd>,<4th>  
                      ADDRGW?

**Description**       Sets the gateway IP address when using the 4294A connected to LAN.

**NOTE**                To bring the setting of the changed gateway IP address to take effect, reboot (turn off and then on again) the 4294A after the setting.

### **Parameters**

	<1st>*1	<2nd>*1	<3rd>*1	<4th>*1
Description	1st number of IP address	2nd number of IP address	3rd number of IP address	4th number of IP address
Range	0 to 255	0 to 255	0 to 255	0 to 255
Initial value	0	0	0	0
Resolution	1	1	1	1

\*1.For example, if the IP address is 1.10.100.50, <1st> is 1, <2nd> is 10, <3rd> is 100, and <4th> is 50.

If the specified parameter is out of the allowable setting range, the minimum value (if the lower limit of the range is not reached) or the maximum value (if the upper limit of the range is exceeded) is set.

**Query response**    {1st},{2nd},{3rd},{4th}<newline><^END>

**Corresponding key**    **[Local] - GATEWAY ADDRESS - 1st, 2nd, 3rd, 4th**

## ADDRIP

**Syntax** ADDRIP <1st>,<2nd>,<3rd>,<4th>  
 ADDRIP?

**Description** Sets the LAN IP address of the 4294A when using the 4294A connected to LAN.

**NOTE** To bring the setting of the changed IP address to take effect, reboot (turn off and then on again) the 4294A after the setting.

### Parameters

	<1st>*1	<2nd>*1	<3rd>*1	<4th>*1
Description	1st number of IP address	2nd number of IP address	3rd number of IP address	4th number of IP address
Range	0 to 255	0 to 255	0 to 255	0 to 255
Initial value	0	0	0	0
Resolution	1	1	1	1

\*1.For example, if the IP address is 1.10.100.50, <1st> is 1, <2nd> is 10, <3rd> is 100, and <4th> is 50.

If the specified parameter is out of the allowable setting range, the minimum value (if the lower limit of the range is not reached) or the maximum value (if the upper limit of the range is exceeded) is set.

**Query response** {1st},{2nd},{3rd},{4th}<newline><^END>

**Corresponding key** [Local] - IP ADDRESS - 1st, 2nd, 3rd, 4th

**ANAODATA**

**Syntax** ANAODATA  
ANAODATA?

**Description** Selects the data trace as the target trace when performing analysis using the waveform analysis command. Only either the data trace or memory trace can be specified as the analysis target. After the execution of this command, executing the “ANAOMEMO” command makes the data trace to be no longer the analysis target.

When the measurement parameter is COMPLEX Z-Y, the analysis target is |Z| (for trace A) or |Y| (for trace B).

**Query response** {1|0}<newline><^END>

	<b>Description</b>
1 (Initial value)	The data trace is selected as the analysis target trace.
0	The data trace is not selected as the analysis target trace (in other words, the memory trace is selected).

**Corresponding key** No front panel key is available to execute this function.

**ANAOMEMO**

**Syntax** ANAOMEMO  
ANAOMEMO?

**Description** Selects the memory trace as the target trace when performing analysis using the waveform analysis command. Only either the data trace or memory trace can be specified as the analysis target. After the execution of this command, executing the “ANAODATA” command makes the memory trace to be no longer the analysis target.

When the measurement parameter is COMPLEX Z-Y, the analysis target is |Z| (for trace A) or |Y| (for trace B).

**Query response** {1|0}<newline><^END>

	<b>Description</b>
1	The memory trace is selected as the analysis target trace.
0 (Initial value)	The memory trace is not selected as the analysis target trace (in other words, the data trace is selected).

**Corresponding key** No front panel key is available to execute this function.

## ANARANG

### Syntax

ANARANG <numeric 1>,<numeric 2>[HZ|MHZ|V|A]

ANARANG?

### Description

Sets the analysis range when performing waveform analysis using the waveform analysis command. You specify the analysis range using the lower limit and the upper limit (or, the upper limit and the lower limit). If the lower/upper limit does not match with any measurement point sweep parameter values, the analysis range lower limit is set to the minimum measurement point larger than the specified value and the analysis range upper limit is set to the maximum measurement point smaller than the specified value.

If the sweep condition setting is changed, the analysis range is set to the entire sweep range. If the sweep range setting is zero span, the analysis range is always the entire sweep range (all measurement points).

### Parameters

		<numeric 1>	<numeric 2>
Description		Analysis range lower limit (or upper limit)	Analysis range upper limit (or lower limit)
Range		Current sweep range	Current sweep range
When the sweep parameter is frequency	Initial value	40	110E6
	Unit	Hz	Hz
	Resolution	1E-3	1E-3
When the sweep parameter is OSC level (voltage)	Initial value	0	1
	Unit	V (volt)	V (volt)
	Resolution	1E-3	1E-3
When the sweep parameter is OSC level (current)	Initial value	40E-6	20E-3
	Unit	A (ampere)	A (ampere)
	Resolution	1E-6	1E-6
When the sweep parameter is dc bias level (voltage)	Initial value	0	0
	Unit	V (volt)	V (volt)
	Resolution	1E-3	1E-3
When the sweep parameter is dc bias level (current)	Initial value	0	0
	Unit	A (ampere)	A (ampere)
	Resolution	20E-6	20E-6

If the specified parameter is out of the allowable setting range, the minimum value (if the lower limit of the range is not reached) or the maximum value (if the upper limit of the range is exceeded) is set.

### Query response

{numeric 1},{numeric 2}<newline><^END>

### Corresponding key

No front panel key is available to execute this function.

**ANARFULL**

- Syntax** ANARFULL
- Description** Sets the analysis range to the entire sweep range when performing waveform analysis using the waveform analysis command. (No query)
- Corresponding key** No front panel key is available to execute this function.

**ANASEGM**

- Syntax** ANASEGM <numeric>  
 ANASEGM?
- Description** When the sweep type is set to the list sweep, selects, from the list sweep table, the waveform analysis target segment when performing analysis using the waveform analysis function. The waveform analysis target segment number is initialized when the sweep type is set to the list sweep from other than the list sweep. Therefore, you have to set the waveform analysis target segment number each time.

**Parameters**

	<b>&lt;numeric&gt;</b>
Description	Waveform analysis target segment number
Range	1 to the number of segments in the list sweep table
Initial value	1
Resolution	1

If the specified parameter is out of the allowable setting range, the minimum value (if the lower limit of the range is not reached) or the maximum value (if the upper limit of the range is exceeded) is set.

- Query response** {numeric}<newline><^END>  
 If the sweep type is not the list sweep, 0 is always read out.

- Corresponding key** No front panel key is available to execute this function.

**AUTO**

- Syntax** AUTO
- Description** Automatically sets scale parameters so that the trace fits on the screen (executes the auto scale). (No query)
- Corresponding key** [Scale Ref] - **AUTO SCALE**



## AVER

**Syntax** AVER {ON|OFF|1|0}  
 AVER?

**Description** Enables/disables the sweep averaging function.

**Parameters**

	Description
ON or 1	Enables the sweep averaging function.
OFF or 0 (Initial value)	Disables the sweep averaging function.

**Query response** {1|0}<newline><^END>

**Corresponding key** [Bw/Avg] - AVERAGING on OFF

## AVERFACT

**Syntax** AVERFACT <numeric>  
 AVERFACT?

**Description** Sets the averaging factor of the sweep averaging function.

**Parameters**

	<numeric>
Description	Averaging factor
Range	1 to 256
Initial value	16
Resolution	1

If the specified parameter is out of the allowable setting range, the minimum value (if the lower limit of the range is not reached) or the maximum value (if the upper limit of the range is exceeded) is set.

**Query response** {numeric}<newline><^END>

**Corresponding key** [Bw/Avg] - AVERAGING FACTOR

## AVERREST

**Syntax** AVERREST

**Description** Resets the data count used in averaging calculation of the sweep averaging function to 0. Measured data before the execution of this command is not used in averaging calculation. If this command is executed while the 4294A is performing a sweep, it is restarted. (No query)

**Corresponding key** [Bw/Avg] - AVERAGING RESTART

**BACI**

**Syntax** BACI <numeric>[PCT]  
 BACI?

**Description** Sets the brightness of the background color on the display screen. You specify the brightness in a percentage of the white level (the level of white, larger means brighter).

**Parameters**

	<b>&lt;numeric&gt;</b>
Description	Percentage of the white level
Range	0 to 100
Initial value	0
Unit	% (percentage ratio)
Resolution	1

If the specified parameter is out of the allowable setting range, the minimum value (if the lower limit of the range is not reached) or the maximum value (if the upper limit of the range is exceeded) is set.

**Query response** {numeric}<newline><^END>

**Corresponding key** [Display] - more 1/2 - MODIFY COLOR - BACKGROUND INTENSITY

**BEEPDONE**

**Syntax** BEEPDONE {ON|OFF|1|0}  
 BEEPDONE?

**Description** Enables/disables the beep to notify the completion of operation (at the completion of calibration or saving instrument states).

**Parameters**

	<b>Description</b>
ON or 1 (initial value)	Enables the beep.
OFF or 0	Disables the beep.

**Query response** {1|0}<newline><^END>

**Corresponding key** [System] -BEEPER - BEEP DONE on OFF

## BEEPFAIL

**Syntax** BEEPFAIL {ON|OFF|1|0}  
 BEEPFAIL?

**Description** Enables/disables the beep when the limit test result is FAIL.

**Parameters**

	Description
ON or 1	Enables the beep.
OFF or 0 (initial value)	Disables the beep.

**Query response** {1|0}<newline><<^END>

**Corresponding key** [System] - LIMIT TEST - BEEP FAIL on OFF

## BEEPWARN

**Syntax** BEEPWARN {ON|OFF|1|0}  
 BEEPWARN?

**Description** Enables/disables the beep when an error message is displayed or when an invalid key is pressed.

**Parameters**

	Description
ON or 1	Enables the beep.
OFF or 0 (initial value)	Disables the beep.

**Query response** {1|0}<newline><<^END>

**Corresponding key** [System] -BEEPER - BEEP WARN on OFF

## **BLIGHT**

**Syntax** BLIGHT {ON|OFF|1|0}  
BLIGHT?

**Description** Toggles on and off the backlight of the LCD screen. If the backlight is off, you cannot read displayed information on the screen.

### **Parameters**

	<b>Description</b>
ON or 1 (initial value)	Turns on the backlight.
OFF or 0	Turns off the backlight.

**Query response** {1|0}<newline><^END>

**Corresponding key** No front panel key is available to execute this function.

## **BMON**

**Syntax** BMON {OFF|VOLT|CURR}  
BMON?

**Description** Sets the measurement item in the dc bias level monitor function.

### **Parameters**

	<b>Description</b>
OFF (initial value)	Turns off the dc bias level monitor function.
VOLT	Specifies the dc bias voltage level monitor.
CURR	Specifies the dc bias current level monitor.

**Query response** {OFF|VOLT|CURR}<newline><^END>

**Corresponding key** [Display] - BIAS LEVEL [ ] - {OFF | VOLT | CURRENT}

## BOTV

**Syntax** BOTV <numeric>[OHM|DEG|RAD|SIE|H|F|PCT]  
 BOTV?

**Description** Sets the minimum value on the display screen in the Y axis (vertical axis) direction (the value of the bottom of the grid).

If the difference between this minimum value and the maximum value on the display screen in the Y axis direction (set with the “TOPV” command on page 443) is less than 10E-15 (for the log Y axis format, the ratio of the maximum value to the minimum value is less than 5), the maximum value is automatically changed so that it becomes larger than the value of the minimum value plus 10E-15 (for the log Y axis format, the value indicating that the ratio of the maximum value to the minimum value is 5). Also, the width of a single grid tick (SCALE/DIV) and the reference line value (REFERENCE VALUE) are automatically changed so that they match with the Y axis minimum value and maximum value setting.

For the log Y axis format, if the sign is different from the display screen maximum value setting, the sign of the maximum value is automatically changed to the same sign as the minimum value.

### Parameters

	<numeric>
Description	Minimum value on the display screen in the Y axis (vertical axis) direction
Range	For formats other than the log Y axis format: -1E9 to 1E9 For the log Y axis format: -200E6 to 200E6
Initial value	For formats other than the log Y axis format: Varies depending on the measurement parameter as follows: For other than $\theta$ : 0 For $\theta$ : -180 For the log Y axis format: Varies depending on the measurement parameter as follows: For  Z , R, X, Rs, Rp: 1 For $\theta$ : 100E-6 For  Y , G, B, D: 1E-6 For Cs, Cp: 1E-9 For Ls, Lp: 10E-6 For Q: 1E-3
Unit	Varies depending on the measurement parameter (refer to the explanation of unit in “SCAL” on page 410).
Resolution	1E-15 *1

\*1.This is the minimum value (when the set value is small). The resolution becomes larger as the set value becomes larger.

If the specified parameter is out of the allowable setting range, the minimum value (if the lower limit of the range is not reached) or the maximum value (if the upper limit of the range is exceeded) is set.

**Query response** {numeric}<newline><^END>

**Corresponding key** [Scale Ref] - **BOTTOM VALUE**

## BWFACT

**Syntax** BWFACT {1|2|3|4|5}  
 BWFACT?

**Description** Sets the bandwidth. To set the bandwidth of each segment when creating the list sweep table, also use this command.

### Parameters

	Description
1 (Initial value)	Specifies bandwidth 1 (shortest measurement time).
2	Specifies bandwidth 2.
3	Specifies bandwidth 3.
4	Specifies bandwidth 4.
5	Specifies bandwidth 5 (longest measurement time, accurate measurement).

Note that, if you use this command to create an additional segment, the setting of the previous segment is used as its initial value.

**Query response** {numeric}<newline><^END>

**Corresponding key** [Bw/Avg] - BAND WIDTH [ ] - {1 FAST | 2 | 3 | 4 | 5 PRECISE}

**CAL{A|B|C}**

**Syntax** CAL{A|B|C}

**Description** Measures OPEN/SHORT/LOAD data for user calibration. The “CALA” command measures OPEN data; the “CALB” command, SHORT data; the “CALC” command, LOAD data. (No query)

**Corresponding key** [CAL] - USER CAL - EXECUTE CAL - {OPEN[ ] | SHORT[ ] | LOAD[ ]}

**CALDON**

**Syntax** CALDON

**Description** Finishes the measurement of user calibration data, calculates the calibration coefficient from the measurement result, and stores it into the volatile memory (RAM). Executing this command automatically turns on the user calibration function (specified to ON with the “CALST” command on page 268). If all the measurements of OPEN/SHORT/LOAD data are not completed, executing this command causes an error and the command is ignored. (No query)

**Corresponding key** [CAL] - USER CAL - EXECUTE CAL - done

## CALECPARA

**Syntax** CALECPARA

**Description** Executes the equivalent circuit analysis depending on the equivalent circuit model specified with the “EQUC” command on page 301, and displays the analysis result (equivalent circuit parameters). The analysis range is the same as that of the marker search function. (No query)

**Corresponding key** [Display] - more 1/2 - EQUIV CKT - CALCULATE PARAMETERS

## CALP

**Syntax** CALP {FIXED|USER}  
 CALP?

**Description** Specifies which measurement points are used for user calibration data and fixture compensation data: (fixed) measurement points provided by the 4294A or user created measurement points (measurement points in the sweep setting at the execution of calibration/compensation).

**Parameters**

	Description
FIXED (Initial value)	Uses the (fixed) measurement points provided by the 4294A.
USER	Uses the user created measurement points.

**Query response** {FIXED|USER}<newline><^END>

**Corresponding key** [Cal] - COMP POINT [ ]

## CALQUI

**Syntax** CALQUI

**Description** Aborts the measurement of user calibration data. (No query)

**Corresponding key** [CAL] - USER CAL - EXECUTE CAL - cancel

## CALS

**Syntax** CALS

**Description** Lists the set values of the user calibration kit (values entered with the “DCALOPEN{G|C}”(279page), “DCALSHOR{R|L}”(280page), and “DCALLOAD{R|L}”(278page) commands). (No query)

**Corresponding key** [Copy] - SELECT CONTENTS - CAL KIT VALUE ►

**CALST**

**Syntax** CALST {ON|OFF|1|0}  
 CALST?

**Description** Toggles on and off the user calibration function. If the user calibration data is not stored (executed with the “CALDON” command on page 266), executing this command to turn on the calibration causes an error and the command is ignored.

**Parameters**

	Description
ON or 1	Turns on the user calibration function.
OFF or 0 (initial value)	Turns off the user calibration function.

**Query response** {1|0}<newline><^END>

**Corresponding key** [Cal] - USER CAL - CORRECTION on OFF

**CBRI**

**Syntax** CBRI <numeric>[PCT]  
 CBRI?

**Description** Sets the brightness of the display color of the item selected with the “COLO” command on page 272.

**Parameters**

	<numeric>
Description	Percentage of brightness (the brightest state: 100 %)
Range	0 to 100
Initial value	Varies depending on the display item selected with the “COLO” command on page 272.
Unit	% (percentage)
Resolution	1

**Query response** {numeric}<newline><^END>

**Corresponding key** [Display] - more 1/2 - MODIFY COLOR - MODIFY ITEM COLOR - MODIFY COLOR - BRIGHTNESS



## CENT

**Syntax**           CENT <numeric>[HZ|MHZ|V|A]  
CENT?

**Description**       Sets the sweep range center value. To set the center value of each segment when creating the list sweep table, also use this command.

**Parameters**

		<numeric>
Description		Center value
When the sweep parameter is frequency	Range	40 to 110E6 (for the linear sweep) 50 to 109.9999E6 (for the log sweep)
	Initial value	55.00002E6
	Unit	Hz
	Resolution	1E-3
When the sweep parameter is OSC level (voltage)	Range	5E-3 to 1
	Initial value	0.502
	Unit	V (volt)
	Resolution	1E-3
When the sweep parameter is OSC level (current)	Range	200E-6 to 20E-3
	Initial value	10.1E-3
	Unit	A (ampere)
	Resolution	1E-6
When the sweep parameter is dc bias level (voltage)	Range	-40 to 40
	Initial value	0
	Unit	V (volt)
	Resolution	1E-3
When the sweep parameter is dc bias level (current)	Range	-100E-3 to 100E-3
	Initial value	0
	Unit	A (ampere)
	Resolution	10E-6

Note that, if you use this command to create a segment, the initial value when creating segment 1 is the current sweep range start value and the initial value when creating an additional segment is the sweep range stop value of the previous segment.

If the specified parameter is out of the allowable setting range, the minimum value (if the lower limit of the range is not reached) or the maximum value (if the upper limit of the range is exceeded) is set.

**Query response**   {numeric}<newline><^END>

**Corresponding key**   [Center]

## **CHAD**

**Syntax** CHAD <string>

**Description** Change the current directory under which file operation is performed. To change it to a directory in a different mass storage, use the “STOD” command on page 432 to change the file operation target mass storage, and then execute this command. (No query)

### **Parameters**

	<b>&lt;string&gt;</b>
Description	Change destination directory name
Range	8 characters or less

Use ".." (2 periods) as the directory name to move to the one-level upper directory.

**Corresponding key** [Save] - FILE UTILITIES - CHANGE DIRECTORY ►

## **CIN**

**Syntax** CIN

CIN?

**Description** Sets the input/output direction of port C of the 24-bit I/O port to input (preset state). To change the input/output direction of port C to output, use the “COUT” command on page 275.

**Query response** {1|0}<newline><^END>

	<b>Description</b>
1	Input is selected as the input/output direction of port C.
0	Output is selected as the input/output direction of port C.

**Corresponding key** No front panel key is available to execute this function.

## CLEL

**Syntax** CLEL

**Description** In the creation/edit of the list sweep table, deletes all segments. Executing this command during the execution of segment creation/edit causes an error. If list sweep table creation/edit has not been started, executing this command automatically starts table creation/edit and then deletes all segments. (No query)

---

**NOTE** Executing the “EDITDONE” command on page 300 brings the created/edited list sweep table to take effect.

---

**Corresponding key** [Sweep] - EDIT LIST - CLEAR LIST ➤

## CLES

**Syntax** CLES

**Description** Clears the error queue, Status Byte Register, Operation Status Register, Standard Event Status Register, and Instrument Event Status Register. This command has the same function as the “\*CLS” command on page 250. (No query)

**Corresponding key** No front panel key is available to execute this function.

## COLO

**Syntax** COLO {TRAD|TRAM|TRBD|TRBM|GRAT|WARN|TEXT|IBT|PEN1|PEN2|PEN3|PEN4|PEN5|PEN6}  
 COLO?

**Description** Specifies a display item to which the changes of the brightness (set with the “CBRI” command on page 268), chroma (set with the “COLOR” command on page 273), and tint (set with the “TINT” command on page 441) of the display color are applied.

**Parameters**

	Description
TRAD (Initial value)	Specifies the trace A data trace as the change target.
TRAM	Specifies the trace A memory trace as the change target.
TRBD	Specifies the trace B data trace as the change target.
TRBM	Specifies the trace B memory trace as the change target.
GRAT	Specifies the grid and some softkey labels as the change target.
WARN	Specifies warning notification text as the change target.
TEXT	Specifies the measured data and text except for warning notification text as the change target.
IBT	Specifies text on the Instrument BASIC screen as the change target.
PEN1-PEN6	Specifies pen 1 to pen 6 on the Instrument BASIC screen as the change target.

**Query response** {TRAD|TRAM|TRBD|TRBM|GRAT|WARN|TEXT|IBT|PEN1|PEN2|PEN3|PEN4|PEN5|PEN6}<newline><^END>

**Corresponding key** [Display] - more 1/2 - MODIFY COLOR - MODIFY ITEM COLOR - {TRC A DATA | TRC A MEM LIMIT LINE | TRC B DATA | TRC B MEM LIMIT LINE | GRATICULE}  
 [Display] - more 1/2 - MODIFY COLOR - MODIFY ITEM COLOR - more 1/3 - {WARNING | TEXT MARKER | IBASIC | PEN 1 | PEN 2}  
 [Display] - more 1/2 - MODIFY COLOR - MODIFY ITEM COLOR - more 1/3 - more 2/3 - {PEN 3 | PEN 4 | PEN 5 | PEN 6}

## COLOR

**Syntax** COLOR <numeric>[PCT]  
 COLOR?

**Description** Sets the vividness (chroma) of the display color of the item selected with the “COLO” command on page 272.

**Parameters**

	<numeric>
Description	Percentage of the most vivid status (status in which white and black are not mixed completely)
Range	0 to 100
Initial value	Varies depending on the display item selected with the “COLO” command on page 272.
Unit	% (percentage)
Resolution	1

If the specified parameter is out of the allowable setting range, the minimum value (if the lower limit of the range is not reached) or the maximum value (if the upper limit of the range is exceeded) is set.

**Query response** {numeric}<newline><^END>

**Corresponding key** [Display] - more 1/2 - MODIFY COLOR - MODIFY ITEM COLOR - MODIFY COLOR - COLOR

## COM{A|B|C}

**Syntax** COM{A|B|C}

**Description** Measures OPEN/SHORT/LOAD data for fixture compensation, calculates the compensation coefficient, and stores it into the volatile memory (RAM). The “COMA” command is for OPEN compensation data; the “COMB” command, for SHORT compensation data; the “COMC” command, for LOAD compensation data. (No query)

**Corresponding key** [Ca] - FIXTURE COMPEN - {OPEN | SHORT | LOAD}

## COMS

**Syntax** COMS

**Description** Lists the set values of the standard used for fixture compensation data measurement (the values entered with the “DCOMOPEN{G|C}” command on page 283, “DCOMSHOR{R|L}” command on page 284, and “DCOMLOAD{R|L}” command on page 282). (No query)

**Corresponding key** [Copy] - SELECT CONTENTS - COMPEN KIT VALUE >

**COMST{A|B|C}**

**Syntax** COMST{A|B|C} {ON|OFF|1|0}  
 COMST{A|B|C}?

**Description** Toggles on and off the OPEN/SHORT/LOAD compensation of the fixture compensation function. The “COMSTA” command is used to set the OPEN compensation; the “COMSTB” command, the SHORT compensation; the “COMSTC” command, the LOAD compensation. If no fixture compensation coefficient has been stored (executed with the “COM{A|B|C}” command on page 273), executing this command to turn on the compensation causes an error and the command is ignored.

**Parameters**

	Description
ON or 1	Turns on the compensation.
OFF or 0 (Initial value)	Turns off the compensation.

**Query response** {1|0}<newline><^END>

**Corresponding key** [Cal] - FIXTURE COMPEN - {OPEN on OFF | SHORT on OFF | LOAD on OFF}

**CONT**

**Syntax** CONT  
 CONT?

**Description** Sets the sweep mode to the auto continuous sweep (CONT). In this mode, sweeps are repeated automatically and continuously.

**Query response** {1|0}<newline><^END>

	Description
1 (Initial value)	The auto continuous sweep is selected as the sweep mode.
0	The auto continuous sweep is not selected as the sweep mode.

**Corresponding key** [Trigger] - CONTINUOUS

**COPA**

**Syntax** COPA

**Description** Aborts printout. (No query)

**Corresponding key** [Copy] - ABORT

## COPT

**Syntax** COPT {ON|OFF|1|0}  
 COPT?

**Description** Enables/disables the output of the time and date to a printer.

**Parameters**

	Description
ON or 1	Enables the output of the time and date.
OFF or 0 (Initial value)	Disables the output of the time and date.

**Query response** {1|0}<newline><<^END>

**Corresponding key** [Copy] - SETUP - more 1/2 - TIME on OFF

## COUT

**Syntax** COUT  
 COUT?

**Description** Sets the input/output direction of port C of the 24-bit I/O port to output.  
 To change the input/output direction of port C to input (preset state), use the “CIN” command on page 270.

**Query response** {1|0}<newline><<^END>

	Description
1	Output is selected as the input/output direction of port C.
0	Input is selected as the input/output direction of port C.

**Corresponding key** No front panel key is available to execute this function.

**CRED**

**Syntax** CRED <string>

**Description** Creates a new directory under the current directory. To change the current directory, use the “CHAD” command on page 270. (No query)

**Parameters**

	<b>&lt;string&gt;</b>
Description	Name of a new directory
Range	8 characters or less

If the specified file name has characters that exceed the maximum length, only the string of up to the maximum length is valid and the remaining characters are ignored.

**Corresponding key** **[Save] - FILE UTILITIES - CREATE DIRECTORY ►**

**CWFREQ**

**Syntax** CWFREQ <numeric>[HZ|MHZ]

CWFREQ?

**Description** Sets the frequency of the oscillator for the oscillator (OSC) level sweep and dc bias level sweep.

**Parameters**

	<b>&lt;numeric&gt;</b>
Description	Frequency of the oscillator
Range	40 to 110E6
Initial value	1E6
Unit	Hz
Resolution	1E-3

If the specified parameter is out of the allowable setting range, the minimum value (if the lower limit of the range is not reached) or the maximum value (if the upper limit of the range is exceeded) is set.

**Query response** {numeric}<newline><^END>

**Corresponding key** **[Source] - FREQUENCY**



## DATMEM

- Syntax** DATMEM
- Description** Copies the measured data into the memory array. It is copied to both the A and B traces.(No query)
- Corresponding key** [Display] - DEF TRACR[ ] - DATA → MEMORY

## DATOVAL

- Syntax** DATOVAL <numeric>  
 DATOVAL?
- Description** For the active trace (set with the “TRAC” command on page 444), if the measurement parameter is a scalar value, sets a value that is subtracted from the data trace (offset value). The contents of the data trace is the result of subtracting the offset value from the measured data (if the contents of the data trace is an operation result depending on the setting with the “DISP” command on page 291, the operation result).
- Parameters**

	<numeric>
Description	Offset value
Range	-100E6 to 100E6
Initial value	0
Resolution	1E-18

If the specified parameter is out of the allowable setting range, the minimum value (if the lower limit of the range is not reached) or the maximum value (if the upper limit of the range is exceeded) is set.

- Query response** {numeric}<newline><^END>
- Corresponding key** [Display] - OFFSET

**DCALLOAD{R|L}**

**Syntax** DCALLOADR <numeric>[OHM]  
 DCALLOADL <numeric>[H]  
 DCALLOAD{R|L}?

**Description** For user calibration data measurement (“CAL{A|B|C}” command on page 266), sets the resistance value (the “DCALLOADR” command) and the inductance value (the “DCALLOADL” command) of the LOAD standard of the calibration kit used to measure LOAD calibration data.

**Parameters**

	<b>&lt;numeric&gt;</b>
Description	Resistance value or inductance value
Range	For resistance value: -100E9 to 100E9 For inductance value: -1E6 to 1E6
Initial value	For resistance value: 50 For inductance value: 0
Unit	For resistance value: Ω (ohm) For inductance value: H (henry)
Resolution	1E-12

If the specified parameter is out of the allowable setting range, the minimum value (if the lower limit of the range is not reached) or the maximum value (if the upper limit of the range is exceeded) is set.

**Query response** {numeric}<newline><^END>

**Corresponding key** [CAL] - USER CAL -DEFINE VAUE - {LOAD RESIST (R) | LOAD INDUCT (L)}

## DCALOPEN{G|C}

**Syntax**  
 DCALOPENG <numeric>[S|E]  
 DCALOPENC <numeric>  
 DCALOPEN {G|C}?

**Description**  
 For user calibration data measurement (“CAL {A|B|C}” command on page 266), sets the conductance value (“DCALOPENG” command) and the capacitance value (“DCALOPENC” command) of the OPEN standard of the calibration kit used to measure OPEN calibration data.

### Parameters

	<numeric>
Description	Conductance value or capacitance value
Range*1	-1E6 to 1E6
Initial value	0
Unit	For conductance value: S (siemens) For capacitance value: fF (femto farad)
Resolution	For conductance value: 1E-12 For capacitance value: 1

\*1. The unit of range value is S (siemens) or F (farad).

If the specified parameter is out of the allowable setting range, the minimum value (if the lower limit of the range is not reached) or the maximum value (if the upper limit of the range is exceeded) is set.

**Query response**     {numeric}<newline><^END>

**Corresponding key**     [CAL] - USER CAL -DEFINE VAUE - {OPEN CONDUCT (G) | OPEN CAP (C)}

**DCALSHOR{R|L}**

**Syntax** DCALSHORR <numeric>[OHM]  
 DCALSHORL <numeric>[H]  
 DCALSHOR{R|L}?

**Description** For user calibration data measurement (“CAL{A|B|C}” command on page 266), sets the resistance value (“DCALSHORR” command) and the inductance value (“DCALSHORL” command) of the SHORT standard of the calibration kit used to measure SHORT calibration data.

**Parameters**

	<b>&lt;numeric&gt;</b>
Description	Resistance value or inductance value
Range	-1E6 to 1E6
Initial value	0
Unit	For resistance value: Ω (ohm) For inductance value: H (henry)
Resolution	1E-12

If the specified parameter is out of the allowable setting range, the minimum value (if the lower limit of the range is not reached) or the maximum value (if the upper limit of the range is exceeded) is set.

**Query response** {numeric}<newline><^END>

**Corresponding key** [CAL] - USER CAL -DEFINE VAUE - {SHORT RESIST (R) | SHORT INDUCT (L)}

## DCI

**Syntax** DCI <numeric>[A]  
DCI?

**Description** Sets the dc bias output level when the dc bias output mode is the current mode or constant-current mode. To set the dc bias output level of each segment when creating the list sweep table, also use this command.

### Parameters

	<numeric>
Description	Output current value of dc bias
Range	-0.1 to 0.1
Initial value	0 (Note that the initial value is the current set value of the dc bias output current, when creating segment 1; the set value of the previous segment, when creating an additional segment.)
Unit	A (ampere)
Resolution	20E-6

If the specified parameter is out of the allowable setting range, the minimum value (if the lower limit of the range is not reached) or the maximum value (if the upper limit of the range is exceeded) is set.

**Query response** {numeric}<newline><^END>

**Corresponding key** [Source] - BIAS MENU - CURRENT LEVEL

## DCMOD

**Syntax** DCMOD {VOLT|CURR|CVOLT|CCURR}  
DCMOD?

**Description** Selects the dc bias output mode. To set the dc bias output mode of each segment when creating the list sweep table, also use this command.

### Parameters

	Description
VOLT (initial value)	Specifies the voltage mode.
CURR	Specifies the current mode.
CVOLT	Specifies the constant-voltage mode.
CCURR	Specifies the constant-current mode.

Note that, if you use this command to create a segment, the initial value when creating segment 1 is the current dc bias output mode and the initial value when creating an additional segment is the set mode of the previous segment.

**Query response** {VOLT|CURR|CVOLT|CCURR}<newline><^END>

**Corresponding key** [Source] - more 1/2 - MODE [ ] - {VOLT | CURRENT | VOLT CONSTANT | CURRENT CONSTANT}

## DCO

**Syntax** DCO {ON|OFF|1|0}  
DCO?

**Description** Turns on/off the dc bias output.

**Parameters**

	Description
ON or 1	Turns on the dc bias output.
OFF or 0 (initial value)	Turns off the dc bias output.

**Query response** {1|0}<newline><^END>

**Corresponding key** [Source] - BIAS MENU - BIAS on OFF

## DCOMLOAD{R|L}

**Syntax** DCOMLOADR <numeric>[OHM]  
DCOMLOADL <numeric>[H]  
DCOMLOAD{R|L}?

**Description** For fixture compensation data measurement (“COM{A|B|C}” command on page 273), sets the resistance value (“DCOMLOADR” command) and the inductance value (“DCOMLOADL” command) of the LOAD standard used to measure LOAD compensation data.

**Parameters**

	<numeric>
Description	Resistance value or inductance value
Range	For resistance value: -100E9 to 100E9 For inductance value: -1E6 to 1E6
Initial value	For resistance value: 50 For inductance value: 0
Unit	For resistance value: Ω (ohm) For inductance value: H (henry)
Resolution	1E-12

If the specified parameter is out of the allowable setting range, the minimum value (if the lower limit of the range is not reached) or the maximum value (if the upper limit of the range is exceeded) is set.

**Query response** {numeric}<newline><^END>

**Corresponding key** [Cal] - FIXTURE COMPEN - DEFINE VALUE - {LOAD RESIST (R) | LOAD INDUCT (L)}

## DCOMOPEN{G|C}

**Syntax**  
 DCOMOPENG <numeric>[SIE]  
 DCOMOPENC <numeric>  
 DCOMOPEN{G|C}?

**Description**  
 For fixture compensation data measurement (“COM{A|B|C}” command on page 273), sets the conductance value (“DCOMOPENG” command) and the capacitance value (“DCOMOPENC” command) of the OPEN standard used to measure OPEN compensation data.

### Parameters

	<numeric>
Description	Conductance value or capacitance value
Range <sup>*1</sup>	-1E6 to 1E6
Initial value	0
Unit	For conductance value: S (siemens) For capacitance value: fF (femto farad)
Resolution	For conductance value: 1E-12 For capacitance value: 1

\*1. The unit of range value is S (siemens) or F (farad).

If the specified parameter is out of the allowable setting range, the minimum value (if the lower limit of the range is not reached) or the maximum value (if the upper limit of the range is exceeded) is set.

**Query response** {numeric}<newline><^END>

**Corresponding key** [Cal] - FIXTURE COMPEN - DEFINE VALUE - {OPEN CONDUCT (G) | OPEN CAP (C)}

**DCOMSHOR{R|L}**

**Syntax** DCOMSHORR <numeric>[OHM]  
 DCOMSHORL <numeric>[H]  
 DCOMSHOR {R|L}?

**Description** For fixture compensation data measurement (“COM{A|B|C}” command on page 273), sets the resistance value (“DCOMSHORR” command) and the inductance value (“DCOMSHORL” command) of the SHORT standard used to measure SHORT compensation data.

**Parameters**

	<b>&lt;numeric&gt;</b>
Description	Resistance value or inductance value
Range	-10E6 to 10E6
Initial value	0
Unit	For resistance value: Ω (ohm) For inductance value: H (henry)
Resolution	1E-12

If the specified parameter is out of the allowable setting range, the minimum value (if the lower limit of the range is not reached) or the maximum value (if the upper limit of the range is exceeded) is set.

**Query response** {numeric}<newline><^END>

**Corresponding key** [Cal] - FIXTURE COMPEN - DEFINE VALUE - {SHORT RESIST(R)| SHORT INDUCT(L)}

**DCRNG**

**Syntax** DCRNG {M1|M10|M100}  
 DCRNG?

**Description** Sets the dc bias range.

**Parameters**

	<b>Description</b>
M1 (initial value)	Specifies the 1-mA range.
M10	Specifies the 10-mA range.
M100	Specifies the 100-mA range.

**Query response** {M1|M10|M100}<newline><^END>

**Corresponding key** [Source] - more 1/2 - MEAS RANGE [ ] - {1mA | 10mA | 100mA}



## DCV

**Syntax** DCV <numeric>[V]  
DCV?

**Description** Sets the dc bias output level when the dc bias output mode is the voltage mode or constant-voltage mode. To set the dc bias output level of each segment when creating the list sweep table, also use this command.

### Parameters

	<numeric>
Description	Output voltage value of the dc bias
Range	-40 to 40
Initial value	0 (Note that the initial value is the current set value of the dc bias output voltage when creating segment 1; the set value of the previous segment, when creating an additional segment.)
Unit	V (volt)
Resolution	1E-3

If the specified parameter is out of the allowable setting range, the minimum value (if the lower limit of the range is not reached) or the maximum value (if the upper limit of the range is exceeded) is set.

**Query response** {numeric}<newline><^END>

**Corresponding key** [Source] - BIAS MENU - VOLTAGE LEVEL

## DEFC

**Syntax** DEFC

**Description** Returns all display color settings to the factory states. (No query)

**Corresponding key** [Display] - more 1/2 - MODIFY COLOR - DEFAULT COLORS

**DEFEC{R1|C1|L1|C0}**

**Syntax** DEFECR1 <numeric>[OHM]  
 DEFEC{C1|C0} <numeric>[F]  
 DEFECL1 <numeric>[H]  
 DEFEC{R1|C1|L1|C0}?

**Description** Defines an R1/C1/L1/C0 equivalent circuit parameter. The “DEFECR1” command defines R1; the “DEFECC1” command, C1; the “DEFECL1” command, L1; the “DEFECC0” command, C0, respectively. For equivalent circuit parameters, refer to “Equivalent circuit analysis” on page 100.

**Parameters**

	<b>&lt;numeric&gt;</b>
Description	Value of the equivalent circuit parameter
Range	-1E18 to 1E18
Initial value	0
Unit	Ω (for the “DEFECR1” command) F (for the “DEFECC1” command and the “DEFECC0” command) H (for the “DEFECL1” command)
Resolution	1E-18

If the specified parameter is out of the allowable setting range, the minimum value (if the lower limit of the range is not reached) or the maximum value (if the upper limit of the range is exceeded) is set.

**Query response** {numeric}<newline><^END>

**Corresponding key** [Display] - more 1/2 - EQUIV CKT - DEFINE PARAMETERS - {R1 | C1 | L1 | C0}

**DFLT**

**Syntax**

DFLT

**Description**

Returns the settings related to printout to the initial states (refer to the table below). (No query)

Setting item	Setting command	Initial state [unit]
Print resolution (DPI)	“DPI” on page 298	75 [DPI]
Form feed	“FORMFEED” on page 307	Enabled
Print orientation (portrait/landscape)	“LANDSCAPE” on page 313	Portrait
Left margin	“LMARG” on page 331	1 [inch]
Top margin	“TMARG” on page 442	1 [inch]
Softkey label output	“PRSOFT” on page 394	Disabled
Time and date output	“COPT” on page 275	Disabled
Print color	“PRIC” on page 394	Black and white

**Corresponding key**

**[Copy] - DEFAULT SETTING**

**DIN**

**Syntax**

DIN  
 DIN?

**Description**

Sets the input/output direction of port D (24-bit I/O port) to input (preset state).  
 To change the input/output direction of port D to output, use the “DOUT” command on page 297.

**Query response**

{1|0}<newline><<^END>

	Description
1	Input is selected as the input/output direction of port D.
0	Output is selected as the input/output direction of port D.

**Corresponding key**

No front panel key is available to execute this function.

**DISA**

**DISA**

**Syntax** DISA {ALLI|HIHB|ALLB|BASS}

DISA?

**Description** Sets the allocation of the measurement result display screen and the HP Instrument BASIC (IBASIC) screen on the LCD screen.

**Parameters**

	Description
ALLI (initial value)	Uses the entire LCD screen as the measurement result display screen.
HIHB	Uses the upper half of the LCD screen as the measurement result display screen and the lower half as the HP IBASIC screen.
ALLB	Uses the entire LCD screen as the HP IBASIC.
BASS	Uses most of the LCD screen as the measurement result display screen, showing the state of HP IBASIC in three lines below the measurement result display screen.

**Query response** {ALLI|HIHB|ALLB|BASS}<newline><^END>

**Corresponding key** [Display] - more1/2 - ALLOCATION - {ALL INSTRUMENT | HALF INSTR HALF BASIC | ALL BASIC | BASIC STATUS}

**DISECIRC**

**Syntax** DISECIRC {ON|OFF|1|0}

DISECIRC?

**Description** Toggles on and off the equivalent circuit model display.

**Parameters**

	Description
ON or 1	Turns on the equivalent circuit model display.
OFF or 0 (initial value)	Turns off the equivalent circuit model display.

**Query response** {1|0}<newline><^END>

**Corresponding key** [Display] - more1/2 - EQUIV CKT - CIRCUIT on OFF

## DISECPARA

**Syntax** DISECPARA {ON|OFF|1|0}  
 DISECPARA?

**Description** Toggles on and off the equivalent circuit parameter display. Executing equivalent circuit analysis (by the execution of “CALECPARA” command on page 267) automatically turns on the equivalent circuit parameter display.

### Parameters

	Description
ON or 1	Turns on the equivalent circuit parameter display.
OFF or 0 (initial value)	Turns off the equivalent circuit parameter display.

**Query response** {1|0}<newline><^END>

**Corresponding key** [Display] - more1/2 - EQUIV CKT - PARAMETERS on OFF

### DISL

**Syntax** DISL

**Description** Displays the list sweep table. (No query)

**Corresponding key** [Copy] - SELECT CONTENTS - LIST SWEEP SEGMENTS ►

### DISLLIST

**Syntax** DISLLIST

**Description** Displays the limit line table. (No query)

**Corresponding key** [Copy] - SELECT CONTENTS - LIMIT TEST SEGMENTS ►

## **DISMAMP**

**Syntax**           DISMAMP {UL|MD}  
DISMAMP?

**Description**       Sets the limit range display format to display the limit line table.

**Parameters**

	<b>Description</b>
UL (initial value)	Specifies the range display format using the limit range upper limit and lower limit.
MD	Specifies the range display format using the limit range central value and range width.

**Query response**    {UL|MD}<newline><^END>

**Corresponding key**    [Copy] - SELECT CONTENTS - LIMIT TEST SEGMENTS - DISP MODE[]

## **DISMPRM**

**Syntax**           DISMPRM {STSP|CTSP}  
DISMPRM?

**Description**       Sets the sweep range display format to display the list sweep table.

**Parameters**

	<b>Description</b>
STSP (initial value)	Specifies the range display format using the sweep range start value and stop value.
CTSP	Specifies the range display format using the sweep range central value and range width.

**Query response**    {STSP|CTSP}<newline><^END>

**Corresponding key**    [Copy] - SELECT CONTENTS - LIST SWEEP SEGMENTS - DISP MODE[]

## DISP

**Syntax** DISP {DATA|MEMO|DATM|DMNM|DELP|DDVM}  
 DISP?

**Description** For the active trace (set with the “TRAC” command on page 444), makes the setting related to the displayed trace.

If a parameter other than DATM is set, the scale setting target trace (set with the “SCAF” command on page 409) and the marker use target trace (set with the “MKRO” command on page 345) are also changed.

If no data has been copied to the memory trace (the “DATMEM” command on page 277 has not been executed), executing this command to set a parameter other than DATA causes an error and the command is ignored.

If the measurement parameter is a scalar value, executing this command to set DDVM causes an error and the command is ignored. If the measurement parameter is a vector value, executing this command to set DELP causes an error and the command is ignored.

### Parameters

	Description <sup>*1</sup>
DATA (initial value)	Displays the data trace. The contents of the data trace is measured data (no operation).
MEMO <sup>*2</sup>	Displays the memory trace.
DATM <sup>*2</sup>	Displays both the data trace and the memory trace at the same time. The contents of the data trace is measured data (no operation).
DMNM <sup>*2</sup>	Displays the data trace. The contents of the data trace is the operation result of DATA - MEM.
DELP <sup>*2,*3</sup>	Displays the data trace. The contents of the data trace is the operation result of (DATA - MEM) / MEM.
DDVM <sup>*2,*4</sup>	Displays the data trace. The contents of the data trace is the operation result of DATA / MEM.

- \*1. In operation expressions in the description, DATA indicates measured data and MEM indicates data of the memory trace.
- \*2. Selectable only when data has been copied in the memory trace.
- \*3. Selectable only when the measurement parameter is a scalar value.
- \*4. Selectable only when the measurement parameter is a vector value.

**Query response** {DATA|MEMO|DATM|DMNM|DELP|DDVM}<newline><^END>

**Corresponding key** [Display] - DEF TRACE[ ] - {DATA | MEMORY | DATA and MEMORY | DATA-MEM | DELTA % | DATA/MEM}

**DMKR**

**Syntax** DMKR {ON|FIX|TRAC|OFF}

DMKR?

**Description** For the active trace (set with the “TRAC” command on page 444), makes the setting of the Δ marker. In the coupled marker mode (set with the “MKRCOUP” command on page 341), the setting is applied to both the A and B traces regardless of the active trace setting. If the marker function is off, executing this command causes an error and the command is ignored.

**Parameters**

	<b>Description</b>
ON	Turns on the Δ marker mode and places the Δ marker at the current marker position.
FIX	Turns on the Δ marker mode and places the fixed Δ marker at the current marker position.
TRAC	Turns on the Δ marker mode and places the tracking Δ marker at the current marker position.
OFF (initial value)	Turns off the Δ marker mode and clears the Δ marker.

**Query response** {ON|FIX|TRAC|OFF}<newline><<^END>

**Corresponding key** [Marker] - ΔMODE MENU - {ΔMKR | FIXED ΔMKR | TRACKING ΔMKR | ΔMKR OFF}



## DMKRAUV

**Syntax** DMKRAUV <numeric>[OHM|DEG|RAD|SIE]  
 DMKRAUV?

**Description** For the active trace (set with the “TRAC” command on page 444), if the measurement parameter is a vector value (for COMPLEX Z-Y), moves the fixed Δ marker at the position of the specified measurement parameter value (subsidiary readout). Executing this command as Query reads out the measurement parameter value of the fixed Δ marker (subsidiary readout).

If the measurement parameter is a scalar value (for other than COMPLEX Z-Y) or if the Δ marker mode is off, executing this command causes an error and the command is ignored.

### Parameters

	<numeric>
Description	Specified measurement parameter value (subsidiary readout)
Range	-100E6 to 100E6
Initial value	0
Unit	Varies depending on the measurement parameter (refer to the explanation of unit in “SCAL” on page 410).

If the specified parameter is out of the allowable setting range, the minimum value (if the lower limit of the range is not reached) or the maximum value (if the upper limit of the range is exceeded) is set.

**Query response** {numeric}<newline><^END>

Reads out the phase for the polar chart format. Reads out reactance (for trace A) or susceptance (for trace B) for the complex plane format.

**Corresponding key** **[Marker] - ΔMODE MENU - FIXED ΔMKR AUX VALUE**

## DMKRP

**Syntax** DMKRP <numeric>

DMKRP?

**Description** For the active trace (set with the “TRAC” command on page 444), moves the  $\Delta$  marker to the specified measurement point. In the coupled marker mode (set with the “MKRCOUP” command on page 341), moves the  $\Delta$  markers of both the A and B traces, regardless of the active trace setting. If this command is executed as Query, it reads out the measurement point number at the  $\Delta$  marker position. If the  $\Delta$  marker mode is off, executing this command causes an error and the command is ignored.

### Parameters

	<numeric>
Description	Number of the destination measurement point (number given in order from the left edge assuming that the number of the left edge measurement point is 1)
Range	1 to the number of points
Initial value	1
Resolution	1

If the specified parameter is out of the allowable setting range, the minimum value (if the lower limit of the range is not reached) or the maximum value (if the upper limit of the range is exceeded) is set.

**Query response** {numeric}<newline><^END>

**Corresponding key** No front panel key is available to execute this function.

## DMKRPRM

**Syntax**                   DMKRPRM <numeric>[HZ|MHZ|V|A]  
 DMRKPRM?

**Description**           For the active trace (set with the “TRAC” command on page 444), moves the Δ marker on the trace to the position of the specified sweep parameter value. Note that, for the fixed Δ marker, the Y axis (vertical axis) value is not changed before and after the move. In the coupled marker mode (set with the “MKRCOUP” command on page 341), regardless of the active trace setting, moves the Δ marker of both the A and B traces. If this command is executed as Query, it reads out the sweep parameter value at the Δ marker position. If the Δ marker mode is off, executing this command causes an error and the command is ignored.

**Parameters**

	<b>&lt;numeric&gt;</b>
Description	Sweep parameter value you want to specify
Range	Sweep start value to sweep stop value
Initial value	0
Unit	Varies depending on the sweep parameter (refer to the explanation of unit in “CENT” on page 269).
Resolution	Varies depending on the sweep parameter (refer to the explanation of resolution in “CENT” on page 269).

If the specified parameter is out of the allowable setting range, the minimum value (if the lower limit of the range is not reached) or the maximum value (if the upper limit of the range is exceeded) is set.

**Query response**       {numeric}<newline><^END>

**Corresponding key**    **[Marker] - ΔMODE MENU - ΔMKR STIMULUS**

**DMKRVAL**

**Syntax** DMRVAL <numeric>[OHM|DEG|RAD|SIE|H|F|PCT]  
 DMRVAL?

**Description** For the active trace (set with the “TRAC” command on page 444), moves the fixed Δ marker to the position of the specified measurement parameter value. Executing this command as Query reads out the measurement parameter value of the fixed Δ marker. If the Δ marker mode is off, executing this command causes an error and the command is ignored.

**Parameters**

	<b>&lt;numeric&gt;</b>
Description	Measurement parameter value you want to specify
Range	-100E6 to 100E6
Initial value	0
Unit	Varies depending on the measurement parameter (refer to the explanation of unit in “SCAL” on page 410)

If the specified parameter is out of the allowable setting range, the minimum value (if the lower limit of the range is not reached) or the maximum value (if the upper limit of the range is exceeded) is set.

**Query response** {numeric}<newline><^END>

If the measurement parameter is a scalar value (for other than COMPLEX Z-Y), the measurement parameter value is read out. If the measurement parameter is a vector value (for COMPLEX Z-Y), the readout is as follows.

- If the polar chart format is selected, the amplitude is read out.
- If the complex plane format is selected, resistance (for trace A) or conductance (for trace B) is read out.

**Corresponding key** **[Marker] - ΔMODE MENU - FIXED ΔMKR VALUE**

## DMODE

**Syntax** DMODE {DMY|MDY}  
 DMODE?

**Description** When the date printout setting is enabled (specified to ON with the “COPT” command on page 275), sets the display format of the date.

**Parameters**

	Description
DMY	Specifies the setting to display the date in the order of Day/Month/Year.
MDY (initial value)	Specifies the setting to display the date in the order of Month/Day/Year.

**Query response** {DMY|MDY}<newline><^END>

**Corresponding key** [System] - **CLOCK -DATE MODE [ ]**

## DOUT

**Syntax** DOUT  
 DOUT?

**Description** Sets the input/output direction of port D (24-bit I/O port) to output.  
 To change the input/output direction of port D to input (preset state), use the “DIN” command on page 287.

**Query response** {1|0}<newline><^END>

	Description
1	Output is selected as the input/output direction of port D.
0	Input is selected as the input/output direction of port D.

**Corresponding key** No front panel key is available to execute this function.

**DPI**

**DPI**

**Syntax**           DPI <numeric>

DPI?

**Description**       Sets the print resolution (DPI) for printout.

**Parameters**

	<b>&lt;numeric&gt;</b>
Description	Print resolution
Range	75 to 600
Initial value	75
Resolution	1

If the specified parameter is out of the allowable setting range, the minimum value (if the lower limit of the range is not reached) or the maximum value (if the upper limit of the range is exceeded) is set.

**Query response**    {numeric}<newline><^END>

**Corresponding key**   **[Copy] - SETUP - DPI**

**DSKEY**

**Syntax**           DSKEY

**Description**       Disables the operation of the front panel keys and the rotary knob. To enable their operation, execute the “ENKEY” command on page 300. (No query)

**Corresponding key**   No front panel key is available to execute this function.

## E4TP

**Syntax** E4TP {OFF|M1|M2|APC7|PROBE}  
 E4TP?

**Description** Selects the adapter in the adapter setting.

**Parameters**

	Description
OFF (initial value)	Specifies no adapter (NONE).
M1	Specifies the Agilent 16048G (4TP 1M).
M2	Specifies the Agilent 16048H (4TP 2M).
APC7	Specifies the Agilent 42942A (7mm 42942A).
PROBE	Specifies the Agilent 42941A (PROBE 42941A).

**Query response** {OFF|M1|M2|APC7|PROBE}<newline><^END>

**Corresponding key** [Ca] - ADAPTER [ ] - {NONE | 4TP 1M | 4TP 2M | 7mm 42942A | PROBE 42941A}

### ECAL{P|A|B|C}

**Syntax** ECAL{P|A|B|C}

**Description** Measures the PHASE/OPEN/SHORT/LOAD data to calculate the setup data of the selected adapter. The “ECALP” command measures the PHASE data; the “ECALA” command, the OPEN data; the “ECALB” command, the SHORT data; the “ECALC” command, LOAD data. These data must be measured for each adapter (selected with the “E4TP” command on page 299). (No query)

**Corresponding key** [Ca] - ADAPTER [ ] - SETUP - {PHASE COMP [ ] | OPEN [ ] | SHORT [ ] | LOAD [ ]}

### ECALDON

**Syntax** ECALDON

**Description** Finishes the measurement of the data for the adapter setup and stores the measured data into the non-volatile memory. The setup data is stored as the data for the adapter selection specified at the measurement (data is stored for each adapter selection). (No query)

**Corresponding key** [Ca] - ADAPTER [ ] - SETUP - done

## ECALQUI

**Syntax** ECALQUI

**Description** Aborts the measurement of data to calculate the setup data of the selected adapter. (No query)

**Corresponding key** [Cal] - ADAPTER [ ] - SETUP - cancel

## EDITDONE

**Syntax** EDITDONE

**Description** Finishes the creation/edit of the list sweep table. Executing this command brings the created/edited table to take effect. (No query)

**Corresponding key** [Sweep] - EDIT LIST - done

## EDITLIML

**Syntax** EDITLIML

**Description** Starts the creation/edit of the limit line table. (No query)

**Corresponding key** [System] - LIMIT TEST - EDIT LIMIT LINE ►

## EDITLIST

**Syntax** EDITLIST

**Description** Starts the creation/edit of the list sweep table. If a segment is being created/edited, executing this command causes an error and the command is ignored. (No query)

**Corresponding key** [Sweep] - EDIT LIST ►

## ENKEY

**Syntax** ENKEY

**Description** Enables the operation of the front panel keys and the rotary knob that has been disabled with the “DSKEY” command on page 298. (No query)

**Corresponding key** No front panel key is available to execute this function.



## EQUC

**Syntax** EQUC {CIRA|CIRB|CIRC|CIRD|CIRE}  
 EQUC?

**Description** Selects an equivalent circuit model (A to E) used when executing the equivalent circuit analysis with the “CALECPARA” command on page 267. For details on each equivalent circuit model, refer to “Equivalent circuit analysis” on page 100.

**Parameters**

	Description
CIRA (initial value)	Specifies equivalent circuit model A.
CIRB	Specifies equivalent circuit model B.
CIRC	Specifies equivalent circuit model C.
CIRD	Specifies equivalent circuit model D.
CIRE	Specifies equivalent circuit model E.

**Query response** {CIRA|CIRB|CIRC|CIRD|CIRE}<newline><^END>

**Corresponding key** [Display] - more 1/2 - EQUIV CKT - SELECT CIRCUIT - {A | B | C | D | E}

## EQUC0?

**Syntax** EQUC0? <numeric 1>[HZ|MHZ]

**Description** If the sweep parameter is frequency, within the waveform analysis range specified with the “ANARANG” command on page 259, reads out equivalent circuit parameter C0 (parallel capacitance) at the specified frequency. If the sweep parameter is not frequency, executing this command causes an error and 0 is always read out.(Query only)

**Parameters**

	<numeric 1>
Description	Frequency you want to specify
Range	40 to 110E6
Unit	Hz
Resolution	1E-3

**Query response** {numeric 2}<newline><^END>

	{numeric 2}
Description	C0 (parallel capacitance) at the specified frequency
Unit	F (farad)

Note that, if the specified frequency is out of the analysis range, 0 is read out.

**Corresponding key** No front panel key is available to execute this function.

## EQUCPARS4?

**Syntax**

EQUCPARS4?

**Description**

If the sweep parameter is frequency and the measurement parameter is  $|Z|-\theta$ , within the waveform analysis range specified with the “ANARANG” command on page 259, analyzes the 4-device equivalent circuit parameters of a crystal oscillator (refer to Figure 16-1) using the admittance characteristic circle diagram (refer to Figure 16-2), and reads out them. If the sweep parameter is not frequency or the measurement parameter is not  $|Z|-\theta$ , executing this command causes an error and all the readouts are 0. (Query only)

Figure 16-1

4-device equivalent circuit of a crystal oscillator

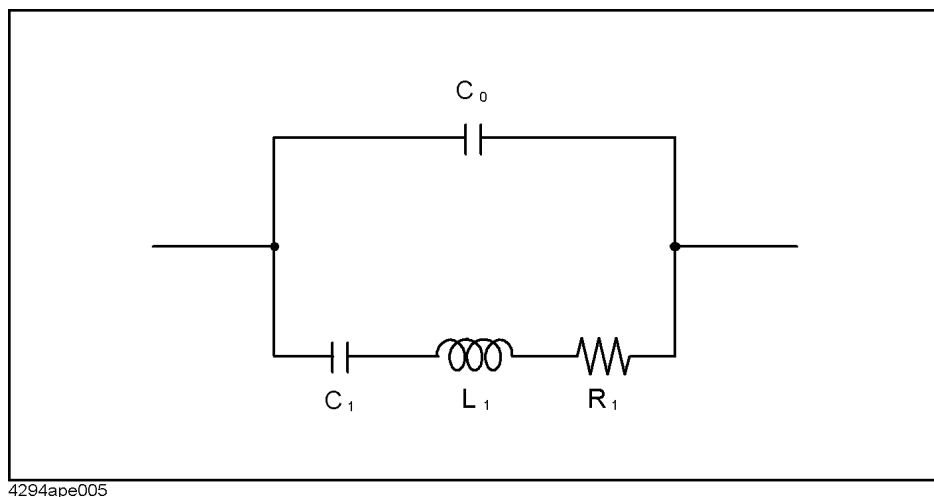

**Query response**

{numeric 1},{numeric 2},{numeric 3},{numeric 4},{numeric 5},{numeric 6},  
 {numeric 7},{numeric 8},{numeric 9}<newline><^END>

Readouts are as follows:

- {numeric 1}: Value of  $C_0$  (parallel capacitance).
- {numeric 2}: Value of  $C_1$  (motional capacitance).
- {numeric 3}: Value of  $L_1$  (motional inductance).
- {numeric 4}: Value of  $R_1$  (motional resistance).
- {numeric 5}: Value of  $f_s$  (motional (series) resonant frequency).
- {numeric 6}: Value of  $f_a$  (anti-resonant frequency).
- {numeric 7}: Value of  $f_r$  (resonant frequency).
- {numeric 8}: Value of  $f_1$  (frequency at which the conductance is half the maximum value).
- {numeric 9}: Value of  $f_2$  (frequency at which the conductance is half the maximum value). Note that  $f_1 < f_2$ .

$C_0$ ,  $C_1$ ,  $L_1$  and  $R_1$  are calculated using the following equations.

$$C_0 = C_1 \times f_r^2 / (f_a^2 - f_r^2)$$

$$C_1 = 1 / (Q \times R_1 \times 2 \times \pi \times f_s)$$

$$L_1 = Q \times R_1 / (2 \times \pi \times f_s)$$

$$R_1 = 1 / G_{\max}$$

$$Q = |f_s / (f_2 - f_1)|$$

If there are no  $f_a$  and  $f_r$  points on the admittance chart,  $C_0$  is calculated using the following equation.

$$C_0 = B_{fs} / (2 \times \pi \times f_s)$$

**Figure 16-2**

**Admittance characteristic circle diagram**

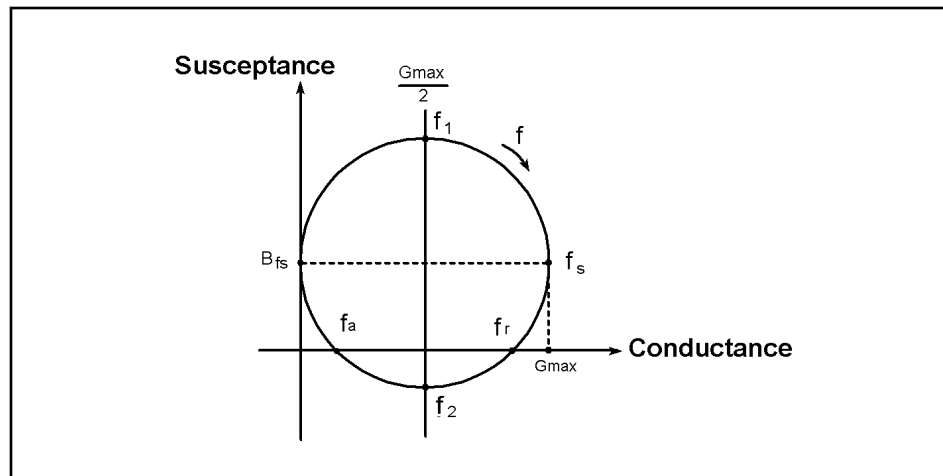

4294ape006

**Corresponding key**

No front panel key is available to execute this function.

**ESB?**

**Syntax**

ESB?

**Description**

Reads out the value of Instrument Event Status Register (Event Status Register B). (Query only)

**Query response**

{numeric}<newline><^END>

**Corresponding key**

No front panel key is available to execute this function.

**ESNB**

**Syntax** ESNB <numeric>  
 ESNB?

**Description** Sets the value of Instrument Event Status Enable Register (Event Status Enable Register B).

**Parameters**

	<numeric>
Description	Value of Instrument Event Status Enable Register
Range	0 to 65535
Initial value	0
Resolution	1

If the specified parameter is out of the allowable setting range, the minimum value (if the lower limit of the range is not reached) or the maximum value (if the upper limit of the range is exceeded) is set.

**Query response** {numeric}<newline><^END>

**Corresponding key** No front panel key is available to execute this function.

**EXPP**

**Syntax** EXPP {ON|OFF|1|0}  
 EXPP?

**Description** For the active trace (set with the “TRAC” command on page 444), if the trace measurement parameter is phase, determines whether to perform the extended phase display (display in which phases out of the range between -180 and 180 are not rolled up). If the trace measurement parameter is not phase, executing this command causes an error and the command is ignored.

**Parameters**

	Description
ON or 1	Enables the extended phase display.
OFF or 0 (initial value)	Disables the extended phase display.

**Query response** {1|0}<newline><^END>

**Corresponding key** [Format] - EXP PHASE on OFF

## FILC

**Syntax** FILC <string 1>,<string 2>,<string 3>,<string 4>

**Description** Copies a file. To specify a file, use a file name including its extension (refer to Table 8-1 on page 113). (No query)

**Parameters**

	<string 1>	<string 2>	<string 3>	<string 4>
Description	Copy source file name	Copy source device name	Copy destination file name	Copy destination device name
Range	12 characters or less (including the extension)	Select from "MEMO", "DISK", or "FLASH"*1	12 characters or less (including the extension)	Select from "MEMO", "DISK", or "FLASH" *1

\*1. Each selection item indicates the device name as shown below.

- "MEMO": RAM disk (volatile)
- "DISK": Diskette
- "FLASH": Flash disk (non-volatile)

**Corresponding key** [Save] - FILE UTILITIES - COPY FILE >

## FMT

**Syntax** FMT {LINY|LOGY|POLA|COMP}

FMT?

**Description** For the active trace (set with the "TRAC" command on page 444), selects the format to display the trace. Depending on the setting of the measurement parameter, the settable display format differs. Trying to select a non-settable display format causes an error and the command is ignored.

**Parameters** For scalar measurement parameters:

	Description
LINY (initial value)	Specifies the linear Y axis format.
LOGY	Specifies the log Y axis format.

For vector measurement parameters:

	Description
POLA	Specifies the polar chart format.
COMP (initial value)	Specifies the complex plane format.

**Query response** {LINY|LOGY|POLA|COMP}<newline><^END>

**Corresponding key** [Format] - {LIN | LOG | COMPLEX | POLAR}

### **FORM2**

<b>Syntax</b>	FORM2
<b>Description</b>	Sets the transfer format for reading array data to the IEEE 32-bit floating point format. For details about transfer formats, refer to “Data Transfer Format” on page 78. (No query)
<b>Corresponding key</b>	No front panel key is available to execute this function.

### **FORM3**

<b>Syntax</b>	FORM3
<b>Description</b>	Sets the transfer format for reading array data to the IEEE 64-bit floating point format. For details about transfer formats, refer to “Data Transfer Format” on page 78. (No query)
<b>Corresponding key</b>	No front panel key is available to execute this function.

### **FORM4**

<b>Syntax</b>	FORM4
<b>Description</b>	Sets the transfer format for reading array data to the ASCII format (preset state). For details about transfer formats, refer to “Data Transfer Format” on page 78. (No query)
<b>Corresponding key</b>	No front panel key is available to execute this function.

### **FORM5**

<b>Syntax</b>	FORM5
<b>Description</b>	Sets the transfer format for reading array data to the MS-DOS personal computer format. For details about transfer formats, refer to “Data Transfer Format” on page 78. (No query)
<b>Corresponding key</b>	No front panel key is available to execute this function.

## FORMFEED

**Syntax** FORMFEED {ON|OFF|1|0}  
FORMFEED?

**Description** Enables/disables form feed for printout.

**Parameters**

	Description
ON or 1 (initial value)	Enables form feed.
OFF or 0	Disables form feed.

**Query response** {1|0}<newline><^END>

**Corresponding key** [Copy] - SETUP - more 1/2 - FORM FEED on OFF

## HIDI

**Syntax** HIDI {ON|OFF|1|0}  
HIDI?

**Description** Hides/shows the inactive trace and the grid.

**Parameters**

	Description
ON or 1	Hides them.
OFF or 0 (initial value)	Shows them.

**Query response** {1|0}<newline><^END>

**Corresponding key** [Display] - HIDE INACT on OFF

## HOLD

**Syntax** HOLD  
HOLD?

**Description** Sets the sweep mode to HOLD. In other words, the sweep is stopped.

**Query response** {1|0}<newline><^END>

	Description
1	The sweep mode is set to HOLD.
0 (initial value)	The sweep mode is not set to HOLD.

**Corresponding key** [Trigger] - HOLD

INID

INID

**Syntax** INID

**Description** Initializes a disk inserted in the flexible disk drive, RAM disk, and flash disk. (No query)

**Corresponding key** [Save] - FILE UTILITIES - FORMAT >

INP8IO?

**Syntax** INP8IO?

**Description** 4-bit data is inputted to the 4294A through IN0 to IN3 of the 8-bit I/O port and the data is read out to the external controller. This command has the same function as the READIO(15,0) command of Instrument BASIC. (Query only)

**Query response** {numeric}<newline><^END>

	{numeric}
Description	Decimal value for the 4-bit binary data inputted from IN0 to IN3, assuming that IN0 is LSB and IN3 is MSB.

**Corresponding key** No front panel key is available to execute this function.

INPT?

**Syntax** INPT?

**Description** Reads out whether a pulse has been inputted to INPUT1 of the 24-bit I/O port, during the period between the last execution of this command and present time. After reading out the presence/absence of pulse inputs with this command, the no-pulse-input state occurs (the query response is 0). (Query only)

**Query response** {1|0}<newline><^END>

	Description
1	Indicates that a pulse has been inputted into INPUT1.
0	Indicates that no pulse has been inputted into INPUT1.

**Corresponding key** No front panel key is available to execute this function.



## INPUCALC{1-3}

**Syntax** INPUCALC{1|2|3} <numeric 1>,<numeric 2>,...,<numeric NOP×2-1>,<numeric NOP×2>

**Description** Enters OPEN/SHORT/LOAD data for user calibration. Use the “INPUCALC1” command to enter OPEN data (G-B); the “INPUCALC2” command, SHORT data (R-X); the “INPUCALC3” command, LOAD data (R-X). When all the OPEN/SHORT/LOAD data is entered, the calibration coefficient is automatically calculated and it is stored into the non-volatile memory (backup memory). To use entered data, you are required to enter all the data.

Enter data after setting the standard values, because the standard values to be used in measuring data is needed to calculate user calibration coefficients.

A mismatch, between the number of required data at the execution of the command (defined by the measurement point setting for user calibration data (set with the “CALP” command on page 267) and the number-of-points setting) and the number of entered parameters, causes an error and the command is ignored. (No query)

### Parameters

	Description
<numeric n×2-1>	Real part of the calibration data value (complex number) for the n-th measurement point
<numeric n×2>	Imaginary part of the calibration data value (complex number) for the n-th measurement point

Total of NOP×2 parameters are required because each measurement point value (complex number) is divided into 2 parameters for its real part and imaginary part. Where, NOP is the number of points (for user measurement points) or 100 (for fixed measurement points), and n is an integer between 1 and NOP.

**Corresponding key** No front panel key is available to execute this function.

### INPUCOMC{1-3}

**Syntax** INPUCOMC{1-3} <numeric 1>,<numeric 2>,...,<numeric NOP×2-1>,<numeric NOP×2>

**Description** Enters the OPEN/SHORT/LOAD compensation data for fixture compensation, calculates the compensation coefficient, and stores it into the non-volatile memory (backup memory). The “INPUCOMC1” command is for OPEN compensation data (G-B); the “INPUCOMC2” command, SHORT compensation data (R-X); the “INPUCOMC3” command, for LOAD compensation data (R-X).

Enter data after setting the standard values, because the standard values to be used in measuring data is needed to calculate fixture compensation coefficients.

A mismatch, between the number of required data at the execution of the command (defined by the measurement point setting for fixture compensation data (set with the “CALP” command on page 267) and the number-of-points setting) and the number of entered parameters, causes an error and the command is ignored. (No query)

**Parameters**

	Description
<numeric n×2-1>	Real part of the compensation data value (complex number) of the n-th measurement point.
<numeric n×2>	Imaginary part of the compensation data value (complex number) of the n-th measurement point.

Total of NOP×2 parameters are required because the fixture compensation data value (complex number) of each measurement point is divided into 2 parameters for its real part and imaginary part. Where, NOP is the number of points (for user measurement points) or 100 (for fixed measurement points), and n is an integer between 1 and NOP.

**Corresponding key** No front panel key is available to execute this function.

### INPUDATA

**Syntax** INPUDATA <numeric 1>,<numeric 2>,...,<numeric NOP×2-1>,<numeric NOP×2>

**Description** Enters a data array (refer to “Internal data arrays” on page 81). A mismatch, between the number-of-points setting at the execution of the command and the number of entered parameters, causes an error and the command is ignored. (No query)

**Parameters**

	Description
<numeric n×2-1>	Real part of the measurement parameter value (complex number) of the n-th measurement point.
<numeric n×2>	Imaginary part of the measurement parameter value (complex number) of the n-th measurement point.

Total of NOP×2 parameters are required because the measurement parameter value of each measurement point (complex number) is divided into 2 parameters for its real part and imaginary part. Where, NOP is the number of points, and n is an integer between 1 and NOP.

**Corresponding key** No front panel key is available to execute this function.

## INPUDTRC

**Syntax** INPUDTRC <numeric 1>,<numeric 2>,...,<numeric NOP×2-1>,<numeric NOP×2>

**Description** Enters a data trace array (refer to “Internal data arrays” on page 81). A mismatch, between the number-of-points setting at the execution of the command and the number of entered parameters, causes an error and the command is ignored. (No query)

**Parameters**

	Description
<numeric n×2-1>	The measurement parameter value of the n-th measurement point. If the measurement parameter is a vector value (COMPLEX Z-Y), the real part of the measurement parameter value (complex number).
<numeric n×2>	If the measurement parameter is a vector value (COMPLEX Z-Y), the imaginary part of the measurement parameter value (complex number) of the n-th measurement point. If the measurement parameter is a scalar value, the value is always 0.

Regardless of the measurement parameter setting, 2 parameters are required for each measurement point (total of NOP×2 parameters). Where, NOP is the number of points, and n is an integer between 1 and NOP.

**Corresponding key** No front panel key is available to execute this function.

## INTE

**Syntax** INTE <numeric>[PCT]  
 INTE?

**Description** Sets the brightness of the LCD screen.

**Parameters**

	<numeric>
Description	Percentage of the brightest status
Range	0 to 100
Initial value	100
Unit	% (percentage)
Resolution	1

If the specified parameter is out of the allowable setting range, the minimum value (if the lower limit of the range is not reached) or the maximum value (if the upper limit of the range is exceeded) is set.

**Query response** {numeric}<newline><^END>

**Corresponding key** [Display] - more 1/2 - MODIFY COLOR - INTENSITY

**KEY**

**Syntax** KEY <numeric>

KEY?

**Description** Executing this command performs the same operation as a press of a specified front panel key. To specify a front panel key, use a key code. For the relationship between each key and its key code, refer to Figure 16-3.

**Figure 16-3** Key code of each key on the front panel

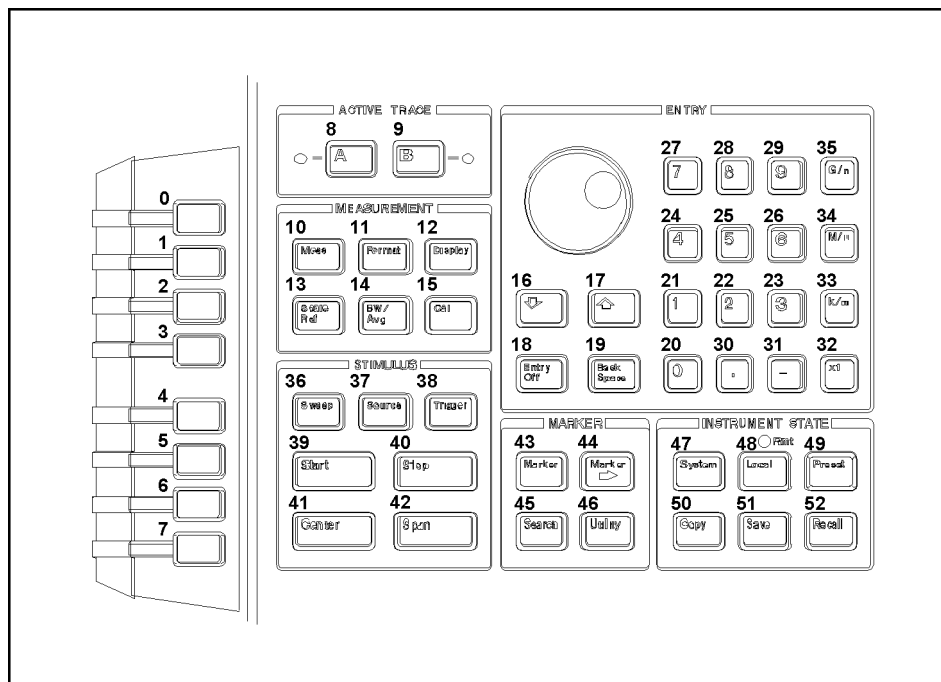

4294api007

**Parameters**

	<numeric>
Description	Key code of the front panel key you want to specify
Range	0 to 52
Initial value	-1
Resolution	1

If the specified parameter is out of the allowable setting range, the minimum value (if the lower limit of the range is not reached) or the maximum value (if the upper limit of the range is exceeded) is set.

**Query response** {numeric}<newline><^END>

The readout is the key code last pressed.

**Corresponding key** No front panel key is available to execute this function.

## LANDSCAPE

- Syntax** LANDSCAPE {ON|OFF|1|0}  
 LANDSCAPE?
- Description** Enables/disables landscape printing for printout.
- Parameters**

	Description
ON or 1	Specifies landscape as the print direction.
OFF or 0 (initial value)	Specifies portrait as the print direction.

- Query response** {1|0}<newline><<^END>
- Corresponding key** [Copy] - SETUP - more 1/2 - LANDSCAPE on OFF

## LIMCLEL

- Syntax** LIMCLEL
- Description** In the creation/edit of the limit line table, deletes all segments. Executing this command during the execution of segment creation/edit causes an error. If the creation/edit of the limit line table has not been started, executing this command automatically starts table creation/edit and then deletes all segments.(No query)
- 
- NOTE** Executing the “LIMEDONE” command on page 315 brings the created/edited limit line table to take effect.
- 
- Corresponding key** [System] - LIMIT TEST - EDIT LIMIT LINE - CLEAR LIST ►

16: GP/IB  
 Command Reference  
 (F - N)

## LIMDSTAR

**Syntax** LIMDSTAR <numeric>[DEG|RAD|OHM|SIE|H|F|PCT]  
 LIMDSTAR?

**Description** In the creation/edit of the limit line table, sets the limit width (=upper value - central value) of the start point of each segment (specified with the “LIMSTAR” command on page 323). Use this command, together with the “LIMVSTAR” command on page 328, when specifying the limits using the central value and the width.

If segment creation/edit has not been started, executing this command automatically starts the edit of the edit target segment and then sets the limit width of the start point.

If the creation/edit of the limit line table has not been started, executing this command automatically starts table creation/edit, starts the edit of the edit target segment and then sets the limit width of the start point.

### Parameters

	<numeric>
Description	Limit width of the segment start point
Range	-1E9 to 1E9
Initial value	When creating segment 1: 0 When creating an additional segment: Set value of the previous segment
Unit	Varies depending on the measurement parameter (refer to the explanation of unit in “SCAL” on page 410).

If the specified parameter is out of the allowable setting range, the minimum value (if the lower limit of the range is not reached) or the maximum value (if the upper limit of the range is exceeded) is set.

**Query response** {numeric}<newline><^END>

**Corresponding key** [System] - LIMIT TEST - EDIT LIMIT LINE - EDIT - DELTA LIMIT

## LIMDSTOP

**Syntax** LIMDSTOP <numeric>[DEG|RAD|OHM|SIE|H|F|PCT]  
 LIMDSTOP?

**Description** In the creation/edit of the limit line table, sets the limit width (=upper value - central value) of the stop point of each segment (specified with the “LIMSTOP” command on page 325). Use this command, together with the “LIMVSTOP” command on page 329, when specifying the limits using the central value and the width.

If segment creation/edit has not been started, executing this command automatically starts the edit of the edit target segment and then sets the limit width of the stop point.

If the creation/edit of the limit line table has not been started, executing this command automatically starts table creation/edit, starts the edit of the edit target segment, and then sets the limit width of the stop point.

**Parameters**

	<b>&lt;numeric&gt;</b>
Description	Limit width of the segment stop point
Range	-1E9 to 1E9
Initial value	When creating segment 1: 0 When creating an additional segment: Set value of the previous segment
Unit	Varies depending on the measurement parameter (refer to the explanation of unit in “SCAL” on page 410).

If the specified parameter is out of the allowable setting range, the minimum value (if the lower limit of the range is not reached) or the maximum value (if the upper limit of the range is exceeded) is set.

**Query response** {numeric}<newline><^END>

**Corresponding key** [System] - LIMIT TEST - EDIT LIMIT LINE - EDIT - more 1/3 - DELTA LIMIT

## LIMEDONE

**Syntax** LIMEDONE

**Description** Finishes the creation/edit of the limit line table. Executing this command brings the created/edited table to take effect. (No query)

**Corresponding key** [System] - LIMIT TEST - EDIT LIMIT LINE - done

## LIMIAMPO

**Syntax** LIMIAMPO <numeric>[DEG|RAD|OHM|SIE|H|F|PCT]  
 LIMIAMPO?

**Description** For the active trace (set with the “TRAC” command on page 444), sets an offset value of the limit for the measurement parameter value.

**Parameters**

	<numeric>
Description	Offset value for the measurement parameter value
Range	-1E9 to 1E9
Initial value	0
Unit	Varies depending on the measurement parameter (refer to the explanation of unit in “SCAL” on page 410).

If the specified parameter is out of the allowable setting range, the minimum value (if the lower limit of the range is not reached) or the maximum value (if the upper limit of the range is exceeded) is set.

**Query response** {numeric}<newline><^END>

**Corresponding key** [System] - LIMIT TEST - LIMIT LINE OFFSETS - AMPLITUDE OFFSET

## LIMIPRMO

**Syntax** LIMIPRMO <numeric>[HZ|MHZ|V|A]  
 LIMIPRMO?

**Description** For the active trace (set with the “TRAC” command on page 444), sets an offset value of the limit for the sweep parameter value.

**Parameters**

	<numeric>
Description	Offset value for the sweep parameter value
Range	-1E9 to 1E9
Initial value	0
Resolution	Varies depending on the sweep parameter (refer to the explanation of resolution in “CENT” on page 269)

If the specified parameter is out of the allowable setting range, the minimum value (if the lower limit of the range is not reached) or the maximum value (if the upper limit of the range is exceeded) is set.

**Query response** {numeric}<newline><^END>

**Corresponding key** [System] - LIMIT TEST - LIMIT LINE OFFSETS - SWP PARAM OFFSET



### LIMITEST

**Syntax**           LIMITEST {ON|OFF|1|0}  
 LIMITEST?

**Description**       For the active trace (set with the “TRAC” command on page 444), toggles on and off the limit test function.

**Parameters**

	Description
ON or 1	Turns on the limit test function.
OFF or 0 (initial value)	Turns off the limit test function.

**Query response**    {1|0}<newline><^END>

**Corresponding key**   **[System] - LIMIT TEST - LIMIT TEST on OFF**

### LIMLSTAR

**Syntax**           LIMLSTAR <numeric>[DEG|RAD|OHM|SIE|H|F|PCT]  
 LIMLSTAR?

**Description**       In the creation/edit of the limit line table, sets the lower limit of the start point of each segment (specified with the “LIMSTAR” command on page 323). Use this command, together with the “LIMUSTAR” command on page 326, when specifying the limits using the upper limit and the lower limit.

If segment creation/edit has not been started, executing this command automatically starts the edit of the edit target segment and then sets the lower limit of the start point.

If the creation/edit of the limit line table has not been started, executing this command automatically starts table creation/edit, starts the edit of the edit target segment, and then sets the lower limit of the start point.

**Parameters**

	<numeric>
Description	Lower limit of the segment start point
Range	-1E9 to 1E9
Initial value	When creating segment 1: 0 When creating an additional segment: Set value of the previous segment
Unit	Varies depending on the measurement parameter (refer to the explanation of unit in “SCAL” on page 410).

If the specified parameter is out of the allowable setting range, the minimum value (if the lower limit of the range is not reached) or the maximum value (if the upper limit of the range is exceeded) is set.

**Query response**    {numeric}<newline><^END>

**Corresponding key**   **[System] - LIMIT TEST - EDIT LIMIT LINE - EDIT - LOWER LIMIT**

## LIMLSTOP

**Syntax** LIMLSTOP <numeric>[DEG|RAD|OHM|SIE|H|F|PCT]

LIMLSTOP?

**Description** In the creation/edit of the limit line table, sets the lower limit of the stop point of each segment (specified with the “LIMSTOP” command on page 325). Use this command, together with the “LIMUSTOP” command on page 327, when specifying the limits using the upper limit and the lower limit.

If segment creation/edit has not been started, executing this command automatically starts the edit of the edit target segment and then sets the lower limit of the stop point.

If the creation/edit of the limit line table has not been started, executing this command automatically starts table creation/edit, starts the edit of the edit target segment, and then sets the lower limit of the stop point.

### Parameters

	<b>&lt;numeric&gt;</b>
Description	Lower limit of the segment stop point
Range	-1E9 to 1E9
Initial value	When creating segment 1: 0 When creating an additional segment: Set value of the previous segment
Unit	Varies depending on the measurement parameter (refer to the explanation of unit in “SCAL” on page 410).

If the specified parameter is out of the allowable setting range, the minimum value (if the lower limit of the range is not reached) or the maximum value (if the upper limit of the range is exceeded) is set.

**Query response** {numeric}<newline><^END>

**Corresponding key** [System] - LIMIT TEST - EDIT LIMIT LINE - EDIT - more 1/3 - LOWER LIMIT

## LIMSADD

### Syntax

LIMSADD [<numeric>]

### Description

In the creation/edit of the limit line table, adds a new segment, changes the edit target segment to the added segment, and starts edit. The position where a segment is added is as follows:

- If a segment is specified:  
Added in the line below the specified segment.
- If no segment is specified:  
Added in the line below the segment specified as the edit target (set with the “LIMSEGM” command on page 322).

The number of the added segment is a value of the specified segment number (if no segment is specified, the edit target segment number before the execution of the command) plus 1, and the number of each following segment also increases by 1.

After the completion of the parameter setting of the segment, execute the “LIMSDON” command on page 320 to finish the edit work. After executing this command and the “LIMSEDI” command on page 321 (to start segment edit), executing this command, without executing the “LIMSDON” command, causes an error and the command is ignored.

If the creation/edit of the limit line table has not been started, executing this command automatically starts table creation/edit and then adds a segment. (No query)

### Parameters

	<numeric>
Description	Segment number immediately before the addition and insertion location
Range	1 to the number of the segments in the limit line table
Resolution	1

If the specified parameter is out of the allowable setting range, the minimum value (if the lower limit of the range is not reached) or the maximum value (if the upper limit of the range is exceeded) is set.

### Corresponding key

[System] - LIMIT TEST - EDIT LIMIT LINE - ADD ►

## LIMSDEL

**Syntax** LIMSDEL [<numeric>]

**Description** In the creation/edit of the limit line table, deletes the specified segment (if no segment is specified, the segment specified as the edit target) from the table.

The segment number of each segment after the deleted segment decreases by 1. As a result, the segment, whose number was changed to the same number as the deleted segment, is set to the edit target. Note that, if the last segment is deleted, the segment immediately before the deleted segment is set to the edit target. You can set any segment to the edit target using the “LIMSEGM” command on page 322.

During segment edit (after the execution of the “LIMSADD” command on page 319 or “LIMSEDI” command on page 321 and before the execution of the “LIMSDON” command on page 320), executing this command causes an error and the command is ignored.

If the creation/edit of the limit line table has not been started, executing this command automatically starts table creation/edit and then deletes the segment. (No query)

---

**NOTE** Executing the “LIMEDONE” command on page 315 brings the created/edited limit line table to take effect.

---

### Parameters

	<numeric>
Description	Segment number you want to delete
Range	1 to the number of the segments in the limit line table
Resolution	1

If the specified parameter is out of the allowable setting range, the minimum value (if the lower limit of the range is not reached) or the maximum value (if the upper limit of the range is exceeded) is set.

**Corresponding key** [System] - LIMIT TEST - EDIT LIMIT LINE - DELETE

## LIMSDON

**Syntax** LIMSDON

**Description** In the creation/edit of the limit line table, finishes segment creation/edit. Executing this command brings the created/edited segment to take effect. (No query)

---

**NOTE** Executing the “LIMEDONE” command on page 315 brings the created/edited limit line table to take effect.

---

**Corresponding key** [System] - LIMIT TEST - EDIT LIMIT LINE - EDIT - done

## LIMSEDI

**Syntax** LIMSEDI <numeric>

**Description** In the creation/edit of the limit line table, starts the edit of the segment specified as the edit target (set with the “LIMSEGM” command on page 322). Note that, if a segment is specified, the edit target segment is changed to the specified segment and then the edit is started.

After the completion of the parameter setting of the segment, execute the “LIMSDON” command on page 320 to finish the edit work. After executing this command and the “LIMSADD” command on page 319 (to start segment edit), executing this command, without executing the “LIMSDON” command, causes an error and the command is ignored.

If the creation/edit of the limit line table has not been started, executing this command automatically starts table creation/edit and then starts the edit of the segment. (No query)

**Parameters**

	<numeric>
Description	Segment number you want to edit
Range	1 to the number of the segments in the limit line table
Resolution	1

If the specified parameter is out of the allowable setting range, the minimum value (if the lower limit of the range is not reached) or the maximum value (if the upper limit of the range is exceeded) is set.

**Corresponding key** [System] - LIMIT TEST - EDIT LIMIT LINE - EDIT ►

## LIMSEGM

**Syntax** LIMSEGM <numeric>

LIMSEGM?

**Description** Sets the execution target segment used when no segment is specified at the execution of the “LIMSEDI” command on page 321, “LIMSADD” command on page 319, and “LIMSDEL” command on page 320. The setting of the execution target segment is initialized when the creation/edit of the limit line table is finished.

If the creation/edit of the limit line table is not started, executing this command automatically starts table creation/edit and then sets the execution target segment.

### Parameters

	<numeric>
Description	Segment number you want to specify as the edit target
Range	1 to the number of the segments in the limit line table
Initial value	Segment number of the last line in the limit line table
Resolution	1

If the specified parameter is out of the allowable setting range, the minimum value (if the lower limit of the range is not reached) or the maximum value (if the upper limit of the range is exceeded) is set.

**Query response** {numeric}<newline><^END>

If the creation/edit of the limit line table is not started, 0 is always read out.

**Corresponding key** [System] - LIMIT TEST - EDIT LIMIT LINE - SEGMENT

## LIMSQUI

**Syntax** LIMSQUI

**Description** In the creation/edit of the limit line table, aborts segment creation/edit. (No query)

**Corresponding key** [System] - LIMIT TEST - EDIT LIMIT LINE - cancel

## LIMSTAR

**Syntax** LIMSTAR <numeric>[HZ|MHZ|V|A]  
 LIMSTAR?

**Description** In the creation/edit of the limit line table, sets the sweep parameter value of each segment start point.

If segment creation/edit has not been started, executing this command automatically starts the edit of the edit target segment and then sets the sweep parameter value of the start point.

If the creation/edit of the limit line table has not been started, executing this command automatically starts table creation/edit, starts the edit of the edit target segment, and then sets the sweep parameter value of the start point.

**Parameters**

	<b>&lt;numeric&gt;</b>
Description	Sweep parameter value of the segment start point
Range	same as “STAR” command on page 431
Initial value	When creating segment 1: same as “STAR” command When creating an additional segment: Set value of the previous segment
Unit	same as “STAR” command
Resolution	same as “STAR” command

If the specified parameter is out of the allowable setting range, the minimum value (if the lower limit of the range is not reached) or the maximum value (if the upper limit of the range is exceeded) is set.

**Query response** {numeric}<newline><^END>

**Corresponding key** [System] - LIMIT TEST - EDIT LIMIT LINE - EDIT - START

## LIMSTEST

**Syntax** LIMSTEST {ON|OFF|1|0}  
LIMSTEST?

**Description** In the creation/edit of the limit line table for the active trace (set with the “TRAC” command on page 444), toggles on and off the limit test function for each segment.

If segment creation/edit has not been started, executing this command automatically starts the edit of the edit target segment and then turns on/off the function.

If the creation/edit of the limit line table has not been started, executing this command automatically starts table creation/edit, starts the edit of the edit target segment, and then turns on/off the function.

### Parameters

	Description
ON or 1 (initial value)	Turns on the segment limit test function.
OFF or 0	Turns off the segment limit test function.

**Query response** {1|0}<newline><^END>

**Corresponding key** [System] - LIMIT TEST - EDIT LIMIT LINE - EDIT - more 1/3 - more 2/3 - TEST on OFF



## LIMSTOP

**Syntax** LIMSTOP <numeric>[HZ|MHZ|V|A]  
 LIMSTOP?

**Description** In the creation/edit of the limit line table, sets the sweep parameter value of each segment stop point.

If segment creation/edit has not been started, executing this command automatically starts the edit of the edit target segment and then sets the sweep parameter value of the stop point.

If the creation/edit of the limit line table has not been started, executing this command automatically starts table creation/edit, starts the edit of the edit target segment, and then sets the sweep parameter value of the stop point.

**Parameters**

	<b>&lt;numeric&gt;</b>
Description	Sweep parameter value of the segment stop point
Range	same as “STOP” command on page 433
Initial value	When creating segment 1: same as “STOP” command When creating an additional segment: Set value of the previous segment
Unit	same as “STOP” command
Resolution	same as “STOP” command

If the specified parameter is out of the allowable setting range, the minimum value (if the lower limit of the range is not reached) or the maximum value (if the upper limit of the range is exceeded) is set.

**Query response** {numeric}<newline><^END>

**Corresponding key** [System] - LIMIT TEST - EDIT LIMIT LINE - EDIT - more 1/3 - STOP

## LIMUSTAR

**Syntax** LIMUSTAR <numeric>[DEG|RAD|OHM|SIE|H|F|PCT]  
LIMUSTAR?

**Description** In the creation/edit of the limit line table, sets the upper limit of the start point of each segment (specified with the “LIMSTAR” command on page 323). Use this command, together with the “LIMLSTAR” command on page 317, when specifying the limits using the upper limit and the lower limit.

If segment creation/edit has not been started, executing this command automatically starts the edit of the edit target segment and then sets the upper limit of the start point.

If the creation/edit of the limit line table has not been started, executing this command automatically starts table creation/edit, starts the edit of the edit target segment, and then sets the upper limit of the start point.

### Parameters

	<b>&lt;numeric&gt;</b>
Description	Upper limit of the segment start point
Range	-1E9 to 1E9
Initial value	When creating segment 1: 0 When creating an additional segment: Set value of the previous segment
Unit	Varies depending on the measurement parameter (refer to the explanation of unit in “SCAL” on page 410).

If the specified parameter is out of the allowable setting range, the minimum value (if the lower limit of the range is not reached) or the maximum value (if the upper limit of the range is exceeded) is set.

**Query response** {numeric}<newline><^END>

**Corresponding key** [System] - LIMIT TEST - EDIT LIMIT LINE - EDIT - UPPER LIMIT

## LIMUSTOP

**Syntax** LIMUSTOP <numeric>[DEG|RAD|OHM|SIE|H|F|PCT]  
 LIMUSTOP?

**Description** In the creation/edit of the limit line table, sets the upper limit of the stop point of each segment (specified with the “LIMSTOP” command on page 325). Use this command, together with the “LIMLSTOP” command on page 318, when specifying the limits using the upper limit and the lower limit.

If segment creation/edit has not been started, executing this command automatically starts the edit of the edit target segment and then sets the upper limit of the stop point.

If the creation/edit of the limit line table has not been started, executing this command automatically starts table creation/edit, starts the edit of the edit target segment, and then sets the upper limit of the stop point.

**Parameters**

	<b>&lt;numeric&gt;</b>
Description	Upper limit of the segment stop point
Range	-1E9 to 1E9
Initial value	When creating segment 1: 0 When creating an additional segment: Set value of the previous segment
Unit	Varies depending on the measurement parameter (refer to the explanation of unit in “SCAL” on page 410).

If the specified parameter is out of the allowable setting range, the minimum value (if the lower limit of the range is not reached) or the maximum value (if the upper limit of the range is exceeded) is set.

**Query response** {numeric}<newline><^END>

**Corresponding key** [System] - LIMIT TEST - EDIT LIMIT LINE - EDIT - more 1/3 - UPPER LIMIT

## LIMVSTAR

**Syntax** LIMVSTAR <numeric>[DEG|RAD|OHM|SIE|H|F|PCT]

LIMVSTAR?

**Description** In the creation/edit of the limit line table, sets the limit central value of each segment start point (specified with the “LIMSTAR” command on page 323). Use this command, together with the “LIMDSTAR” command on page 314, when specifying the limits using the central value and the width.

If segment creation/edit has not been started, executing this command automatically starts the edit of the edit target segment and then sets the limit central value of the start point.

If the creation/edit of the limit line table has not been started, executing this command automatically starts table creation/edit, starts the edit of the edit target segment, and then sets the limit central value of the start point.

### Parameters

	<numeric>
Description	Limit central value of the segment start point
Range	-1E9 to 1E9
Initial value	When creating segment 1: 0 When creating an additional segment: Set value of the previous segment
Unit	Varies depending on the measurement parameter (refer to the explanation of unit in “SCAL” on page 410).

If the specified parameter is out of the allowable setting range, the minimum value (if the lower limit of the range is not reached) or the maximum value (if the upper limit of the range is exceeded) is set.

**Query response** {numeric}<newline><^END>

**Corresponding key** [System] - LIMIT TEST - EDIT LIMIT LINE - EDIT - MIDDLE VALUE

## LIMVSTOP

**Syntax** LIMVSTOP <numeric>[DEG|RAD|OHM|SIE|H|F|PCT]  
 LIMVSTOP?

**Description** In the creation/edit of the limit line table, sets the limit central value of each segment stop point (specified with the “LIMSTOP” command on page 325). Use this command, together with the “LIMDSTOP” command on page 315, when specifying the limits using the central value and the width.

If segment creation/edit has not been started, executing this command automatically starts the edit of the edit target segment and then sets the limit central value of the stop point.

If the creation/edit of the limit line table has not been started, executing this command automatically starts table creation/edit, starts the edit of the edit target segment, and then sets the limit central value of the stop point.

**Parameters**

	<b>&lt;numeric&gt;</b>
Description	Limit central value of the segment stop point
Range	-1E9 to 1E9
Initial value	When creating segment 1: 0 When creating an additional segment: Set value of the previous segment
Unit	Varies depending on the measurement parameter (refer to the explanation of unit in “SCAL” on page 410).

If the specified parameter is out of the allowable setting range, the minimum value (if the lower limit of the range is not reached) or the maximum value (if the upper limit of the range is exceeded) is set.

**Query response** {numeric}<newline><^END>

**Corresponding key** [System] - LIMIT TEST - EDIT LIMIT LINE - EDIT - more 1/3 - MIDDLE VALUE

**LISPAN**

**LISPAN**

**Syntax** LISPAN {SINGLE|SEGMENT}

LISPAN?

**Description** Sets the display of the frequency span at list sweep: using the range from the minimum value to the maximum value in all segments (single span), or using segment-by-segment allocation.

**Parameters**

	Description
SINGLE (initial value)	Specifies the single span display as the display method of the frequency span.
SEGMENT	Specifies the segment-by-segment display as the display method of the frequency span.

**Query response** {SINGLE|SEGMENT}<newline><^END>

**Corresponding key** [Sweep] - LIST SPAN [ ]

**LISV**

**Syntax** LISV

**Description** Displays the tabular list of all measurement points and measured values at each measurement point. Each measured value is updated each time a sweep is completed. To return to the normal measurement screen, execute the “RESD” command on page 399. (No query)

**Corresponding key** [Copy] - SELECT CONTENTS - LIST VALUE ►

## LMARG

**Syntax** LMARG <numeric>  
 LMARG?

**Description** Sets the left margin (white space) on printed forms for printout.

**Parameters**

	<numeric>
Description	Left margin
Range	0 to 5
Initial value	1
Unit	inch
Resolution	0.01

If the specified parameter is out of the allowable setting range, the minimum value (if the lower limit of the range is not reached) or the maximum value (if the upper limit of the range is exceeded) is set.

**Query response** {numeric}<newline><^END>

**Corresponding key** [Copy] - SETUP - LFT MARGIN

## LMAXS?

**Syntax** LMAXS? <numeric 1>

**Description** Reads out the measurement parameter value and sweep parameter value of the peak at the location specified with the order from the left edge of the sweep range among all peaks within the waveform analysis range set with the “ANARANG” command on page 259.

The peak searched for at the execution of this command satisfies the condition set with the “THRR” command on page 439. It is not related to the peak definition in the marker search function. (Query only)

### Parameters

	<numeric 1>
Description	Location of the peak (the order of the peak from the left)
Range	1 to the number of points
Resolution	1

If the specified parameter is out of the setting range, the operation is the same as when no peak is detected.

**Query response** {numeric 2}, {numeric 3}<newline><^END>

	{numeric 2}	{numeric 3}
Description	Measurement parameter value	Sweep parameter value

If the specified peak is not detected, the readouts of {numeric 2} and {numeric 3} are 3.40282346638529E+038 and 0, respectively.

**Corresponding key** No front panel key is available to execute this function.



## LMINS?

**Syntax** LMINS? <numeric 1>

**Description** Reads out the measurement parameter value and sweep parameter value of the negative peak at the location specified with the order from the left edge of the sweep range among all negative peaks within the waveform analysis range set with the “ANARANG” command on page 259.

The negative peak searched for at the execution of this command satisfies the condition set with the “THRR” command on page 439. It is not related to the peak definition in the marker search function. (Query only)

**Parameters**

	<numeric 1>
Description	Location of the negative peak (the order of the negative peak from the left)
Range	1 to the number of points
Resolution	1

If the specified parameter is out of the setting range, the operation is the same as when no peak is detected.

**Query response** {numeric 2},{numeric 3}<newline><^END>

	{numeric 2}	{numeric 3}
Description	Measurement parameter value	Sweep parameter value

If the specified negative peak is not detected, the readouts of {numeric 2} and {numeric 3} are 3.40282346639E+38 and 0, respectively.

**Corresponding key** No front panel key is available to execute this function.

## **MANP**

**Syntax** MANP <value>

MANP?

**Description** When the manual sweep function is on, sets a measurement point.

### **Parameters**

	<b>&lt;value&gt;</b>
Description	A measurement point number (number assigned in order from the left end assuming that the left end measurement point is 1).
Range	1 to the number of measurement points
Preset value	1
Resolution	1

If the specified parameter is out of the allowable setup range, the minimum value (if the lower limit of the range is not reached) or the maximum value (if the upper limit of the range is exceeded) is set.

After the execution of the command, the sweep range specified with the “MANR”(335page) command is canceled and the query response is (0,0).

**Query response** {value}<newline><^END>

**Equivalent key** No equivalent key is available on the front panel.

## MANR

**Syntax** MANR <value 1>,<value 2>  
 MANR?

**Description** When the manual sweep function is on, sets a measurement range. You need to turn on the manual sweep with the “MANS”(336page) command before executing this command.

**Parameters**

	<value 1>	<value 2>
Description	The number of the sweep start point	The number of the sweep stop point
	Measurement point numbers are assigned in order from the left end assuming that the left end measurement point is 1.	
Range	1 to the number of measurement points or both <value 1> and <value 2> are 0.	
Preset value	0	0
Resolution	1	1

**NOTE** When both <value 1> and <value 2> are 0, the measurement range for the manual sweep is set to the measurement point specified with the “MANP” on page 334 command.

Only when the specified parameters satisfy the condition value 1 < value 2, the sweep range is set properly. If this condition is not satisfied, the following occurs.

Condition	Change of setting
value ≤ 0	When both value 1 and value 2 are 0, they do not change. The sweep is performed for the point specified with the “MANP”(334page) command. Otherwise, 1 is set.
value > the number of measurement points	The value is set to the number of measurement points.
value 1 ≥ value 2	Value 1 is set to the value of value 2. The sweep is performed for the point specified with the “MANP”(334page) command.

**Query response** {value 1},{value 2}<newline><^END>

**Equivalent key** No equivalent key is available on the front panel.

**MANS**

**MANS**

**Syntax** MANS {ON|OFF|1|0}  
MANS?

**Description** Turns on/off the manual sweep function.

**Parameters**

	Description
ON or 1	Turns on the manual sweep function.
OFF or 0 (initial value)	Turns off the manual sweep function.

**Query response** {1|0}<newline><^END>

**Corresponding key** [Sweep] - MANUAL SWP on OFF

**MAXDCV**

**Syntax** MAXDCV <numeric>[V]  
MAXDCV?

**Description** Sets the voltage limit maximum value when the dc bias output mode is the constant-voltage mode or constant-current mode (CVOLT or CCURR has been specified with the “DCMOD” command on page 281).

**Parameters**

	<numeric>
Description	Voltage limit maximum value of the dc bias output
Range	-40 to 40
Initial value	40
Unit	V (volt)
Resolution	1E-3

If the specified parameter is out of the allowable setting range, the minimum value (if the lower limit of the range is not reached) or the maximum value (if the upper limit of the range is exceeded) is set.

**Query response** {numeric}<newline><^END>

**Corresponding key** [Source] - BIAS MENU - MAX LIMIT VORTAGE

## MEAS

### Syntax

MEAS {IMPH|IRIM|LSR|LSQ|CSR|CSQ|CSD|AMPH|ARIM|LPG|LPQ|CPG|CPQ|CPD|COMP|IMLS|IMCS|IMLP|IMCP|IMRS|IMQ|IMD|LPR|CPR}  
MEAS?

### Description

Selects impedance measurement parameters as a pair for trace A and trace B. Selecting COMP specifies the vector measurement; selecting others, the scalar measurement. There are functional differences between the vector measurement and the scalar measurement including available display formats and trace operations.

### Parameters

	Set measurement parameters	
	Trace A	Trace B
IMPH (initial value)	Z	$\theta$
IRIM	R	X
LSR	Ls	Rs
LSQ	Ls	Q
CSR	Cs	Rs
CSQ	Cs	Q
CSD	Cs	D
AMPH	Y	$\theta$
ARIM	G	B
LPG	Lp	G
LPQ	Lp	Q
CPG	Cp	G
CPQ	Cp	Q
CPD	Cp	D
COMP	Z	Y
IMLS	Z	Ls
IMCS	Z	Cs
IMLP	Z	Lp
IMCP	Z	Cp
IMRS	Z	Rs
IMQ	Z	Q
IMD	Z	D
LPR	Lp	Rp
CPR	Cp	Rp

For details on each measurement parameter, refer to “Setting Measurement Parameters” on page 36.

### Query response

{IMPH|IRIM|LSR|LSQ|CSR|CSQ|CSD|AMPH|ARIM|LPG|LPQ|CPG|CPQ|CPD|COMP|IMLS|IMCS|IMLP|IMCP|IMRS|IMQ|IMD|LPR|CPR}<newline><<^END>

**MEASTAT**

**Corresponding key** [Meas] - {|Z|-θ | R - X | Ls - Rs | Ls - Q | Cs - Rs | Cs - Q | Cs - D}  
 [Meas] - more 1/3 - {|Y|-θ | G - B | Lp - G | Lp - Q | Cp - G | Cp - Q | Cp - D}  
 [Meas] - more 1/3 - more 2/3 - {COMPLEX Z-Y | |Z| - Ls | |Z| - Cs | |Z| - Lp | |Z| - Cs}  
 [Meas] - more 1/3 - more 2/3 - other - {|Z| - Rs | |Z| - Q | |Z| - D | Lp - Rp | Cp - Rp}

**MEASTAT**

**Syntax** MEASTAT {ON|OFF|1|0}  
 MEASTAT?

**Description** For the active trace (set with the “TRAC” command on page 444), determines whether to, after the completion of each sweep, calculate the statistics (mean value, standard deviation, and difference value between the maximum value and the minimum value), of the search range in the trace selected as the marker use target trace (set with the “MKRO” command on page 345) and display the result on the screen.

**Parameters**

	Description
ON or 1	Enables the statistics display.
OFF or 0 (initial value)	Disables the statistics display.

**Query response** {1|0}<newline><^END>

**Corresponding key** [Utility] - STATISTICS on OFF

## MINDCV

**Syntax** MINDCV <numeric>[V]  
 MINDCV?

**Description** Sets the voltage limit minimum value when the dc bias output mode is the constant-voltage mode or constant-current mode (CVOLT or CCURR has been specified with the “DCMOD” command on page 281).

**Parameters**

	<b>&lt;numeric&gt;</b>
Description	Voltage limit minimum value of the dc bias output
Range	-40 to 40
Initial value	-40
Unit	V (volt)
Resolution	1E-3

If the specified parameter is out of the allowable setting range, the minimum value (if the lower limit of the range is not reached) or the maximum value (if the upper limit of the range is exceeded) is set.

**Query response** {numeric}<newline><^END>

**Corresponding key** [Source] - **BIAS MENU - MIX LIMIT VOLTAGE**

## MKR

**Syntax** MKR {ON|OFF|1|0}  
 MKR?

**Description** For the active trace (set with the “TRAC” command on page 444), toggles on and off the marker function. In the coupled marker mode (set with the “MKRCOUP” command on page 341), the setting is applied to both the A and B traces regardless of the active trace setting. Turning off the marker function using this command initializes the marker related settings.

**Parameters**

	<b>Description</b>
ON or 1	Turns on the marker function.
OFF or 0 (initial value)	Turns off the marker function.

**Query response** {1|0}<newline><^END>

**Corresponding key** [Marker] - **MKR ON off**

## MKRAMPO

<b>Syntax</b>	MKRAMPO
<b>Description</b>	For the active trace (set with the “TRAC” command on page 444), sets the measurement parameter value at the marker position as the offset value of the limit for the measurement parameter value. (No query)
<b>Corresponding key</b>	<b>[System] - LIMIT TEST - LIMIT LINE OFFSETS - MKR → AMP. OFST.</b>

## MKRAUV?

<b>Syntax</b>	MKRAUV?
<b>Description</b>	For the active trace (set with the “TRAC” command on page 444), if the measurement parameter is a vector value (for COMPLEX Z-Y), reads out the subsidiary readout of the measurement parameter value at the marker position. (Query only)
<b>Query response</b>	{numeric}<newline><^END>  If the measurement parameter is a scalar value (for other than COMPLEX Z-Y), 0 is always read out. If the measurement parameter is a vector value (for COMPLEX Z-Y), the value is as follows. <ul style="list-style-type: none"><li>• If the polar chart format is selected, the phase is read out.</li><li>• If the complex plane format is selected, reactance (for trace A) or susceptance (for trace B) is reads out.</li></ul>
<b>Corresponding key</b>	No front panel key is available to execute this function.

## MKRCENT

<b>Syntax</b>	MKRCENT
<b>Description</b>	For the active trace (set with the “TRAC” command on page 444), sets the sweep parameter value at the marker position as the center value of the sweep range. To set the center value of each segment when creating the list sweep table, also use this command. If the marker function is off, executing this command causes an error and the command is ignored. (No query)
<b>Corresponding key</b>	<b>[Marker→] - MKR → CENTER</b>



## MKRCOUP

**Syntax** MKRCOUP {ON|OFF|1|0}  
MKRCOUP?

**Description** As the marker move setting, selects the mode in which the markers on traces A and B are coupled when they are moved (coupled marker mode) or the mode in which the markers on traces A and B are moved separately. (uncoupled marker mode).

If the markers on traces A and B are at different positions when changing the mode from the uncoupled marker mode to the coupled marker mode, to the position of the marker on the active trace (set with the “TRAC” command on page 444), the other marker is moved.

**Parameters**

	Description
ON or 1 (initial value)	Specifies the coupled marker mode.
OFF or 0	Specifies the uncoupled marker mode.

**Query response** {1|0}<newline><^END>

**Corresponding key** [Marker] - MKR COUPLE ON off

## MKRDSPAN

**Syntax** MKRDSPAN

**Description** For the active trace (set with the “TRAC” command on page 444), sets the sweep parameter value difference between the  $\Delta$  marker and the marker as the span value of the sweep range. If the  $\Delta$  marker mode is off, executing this command causes an error and the command is ignored. (No query)

**Corresponding key** [Marker $\rightarrow$ ] - MKR $\Delta$   $\rightarrow$  SPAN

## MKRL

**Syntax** MKRL {ON|OFF|1|0}  
MKRL?

**Description** For the active trace (set with the “TRAC” command on page 444), toggles on and off the marker list function. If the marker function is off, executing this command causes an error and the command is ignored.

**Parameters**

	Description
ON or 1	Turns on the marker list function.
OFF or 0 (initial value)	Turns off the marker list function.

**Query response** {1|0}<newline><^END>

**Corresponding key** [Utility] - MKR LIST on OFF

## **MKRLIMSTAR**

<b>Syntax</b>	MKRLIMSTAR
<b>Description</b>	<p>In the creation/edit of the limit line table, sets the sweep parameter value at the marker position as the sweep parameter value of the segment start point. This command is used, together with the “MKRLIMVSTAR” command on page 343, usually when setting the sweep parameter value and measured value at the marker position as the sweep parameter value and limit central value of the segment start point, respectively.</p> <p>If segment creation/edit has not been started, executing this command automatically starts the edit of the edit target segment and then sets the sweep parameter value of the start point.</p> <p>If the creation/edit of the limit line table has not been started, executing this command automatically starts table creation/edit, starts the edit of the edit target segment, and then sets the sweep parameter value of the start point.</p> <p>If the marker function is off, executing this command causes an error and the command is ignored. (No query)</p>
<b>Corresponding key</b>	<b>[System] - LIMIT TEST - EDIT LIMIT LINE - EDIT - more 1/3 - more 2/3 - MKR → START</b>
	<b>MKRLIMSTOP</b>
<b>Syntax</b>	MKRLIMSTOP
<b>Description</b>	<p>In the creation/edit of the limit line table, sets the sweep parameter value at the marker position as the sweep parameter value of the segment stop point. This command is used, together with the “MKRLIMVSTOP” command on page 343, usually when setting the sweep parameter value and measured value at the marker position as the sweep parameter value and limit central value of the segment stop point, respectively.</p> <p>If segment creation/edit has not been started, executing this command automatically starts the edit of the edit target segment and then sets the sweep parameter value of the stop point.</p> <p>If the creation/edit of the limit line table has not been started, executing this command automatically starts table creation/edit, starts the edit of the edit target segment, and then sets the sweep parameter value of the stop point.</p> <p>If the marker function is off, executing this command causes an error and the command is ignored. (No query)</p>
<b>Corresponding key</b>	<b>[System] - LIMIT TEST - EDIT LIMIT LINE - EDIT - more 1/3 - more 2/3 - MKR → STOP</b>

## MKRLIMVSTAR

<b>Syntax</b>	MKRLIMVSTAR
<b>Description</b>	<p>In the creation/edit of the limit line table, sets the measured value of the marker position as the limit central value of the segment start point. This command is used, together with the “MKRLIMSTAR” command on page 342, usually when setting the sweep parameter value and measured value at the marker position as the sweep parameter value and limit central value of the segment start point, respectively.</p> <p>If segment creation/edit has not been started, executing this command automatically starts the edit of the edit target segment and then sets the limit central value of the start point.</p> <p>If the creation/edit of the limit line table has not been started, executing this command automatically starts table creation/edit, starts the edit of the edit target segment, and then sets the limit central value of the start point.</p> <p>If the marker function is off, executing this command causes an error and the command is ignored. (No query)</p>
<b>Corresponding key</b>	<p><b>[System] - LIMIT TEST - EDIT LIMIT LINE - EDIT - more 1/3 - more 2/3</b>  <b>- MKR → VALUE STAR</b></p>

## MKRLIMVSTOP

<b>Syntax</b>	MKRLIMVSTOP
<b>Description</b>	<p>In the creation/edit of the limit line table, sets the measured value of the marker position as the limit central value of the segment stop point. This command is used, together with the “MKRLIMSTOP” command on page 342, usually when setting the sweep parameter value and measured value at the marker position as the sweep parameter value and limit central value of the segment stop point, respectively.</p> <p>If segment creation/edit has not been started, executing this command automatically starts the edit of the edit target segment and then sets the limit central value of the stop point.</p> <p>If the creation/edit of the limit line table has not been started, executing this command automatically starts table creation/edit, starts the edit of the edit target segment, and then sets the limit central value of the stop point.</p> <p>If the marker function is off, executing this command causes an error and the command is ignored. (No query)</p>
<b>Corresponding key</b>	<p><b>[System] - LIMIT TEST - EDIT LIMIT LINE - EDIT - more 1/3 - more 2/3</b>  <b>- MKR → VALUE STOP</b></p>

## MKRMANP

<b>Syntax</b>	MKRMANP
<b>Description</b>	<p>If the manual sweep function is on, sets the sweep parameter value at the marker position as the measurement point. (No query)</p>
<b>Corresponding key</b>	<p><b>[Marker→] - MKR → MANUAL SWP</b></p>

**MKRMON**

**Syntax** MKRMON {OFF|ACV|ACI|DCV|DCI}  
 MKRMON?

**Description** Enables/disables the display of the oscillator (OSC) level or dc bias level monitor value at the marker position measurement point. If you try to specify monitoring an item whose level monitor has been disabled in the oscillator level monitor function (set with the “OMON” command on page 354) or dc bias level monitor function (set with the “BMON” command on page 264), executing this command causes an error and the command is ignored.

**Parameters**

	Description
OFF (initial value)	Turns off the marker level monitor function.
ACV	Specifies the monitor value display of the oscillator voltage level.
ACI	Specifies the monitor value display of the oscillator current level.
DCV	Specifies the monitor value display of the dc bias voltage level.
DCI	Specifies the monitor value display of the dc bias current level.

**Query response** {OFF|ACV|ACI|DCV|DCI}<newline><^END>

**Corresponding key** [Utility] - LEVEL MON [ ] - {OFF | AC-V | AC-I | DC-V | DC-I}

**MKRMOV**

**Syntax** MKRMOV {CONT|DISC}  
 MKRMOV?

**Description** For the active trace (set with the “TRAC” command on page 444), switches between the continuous marker mode (markers can be moved to between measurement points) and the discrete marker mode (markers can be to measurement points only). In the coupled marker mode (set with the “MKRCOUP” command on page 341), regardless of the active trace setting, this setting is applied to both the A and B traces. In the continuous marker mode, the marker readout is an interpolated value derived from the data of the measurement points on both sides.

**Parameters**

	Description
CONT (initial value)	Specifies the continuous marker mode.
DISC	Specifies the discrete marker mode.

**Query response** {CONT|DISC}<newline><^END>

**Corresponding key** [Marker] - MKR [ ]

## MKRO

**Syntax** MKRO {DATA|MEMO}  
 MKRO?

**Description** For the active trace (set with the “TRAC” command on page 444), sets the trace on which you want to use the markers. The displayed traces are the settable trace. Executing this command to specify a trace not displayed causes an error and the command is ignored.

**Parameters**

	Description
DATA (initial value)	Specifies the data trace.
MEMO	Specifies the memory trace.

**Query response** {DATA|MEMO}<newline><^END>

**Corresponding key** [Marker] -MKR [ ]

## MKROFS

**Syntax** MKROFS

**Description** For the active trace (set with the “TRAC” command on page 444), sets the measurement parameter value at the marker position to the trace offset value. If the marker function is off, executing this command causes an error and the command is ignored. (No query)

**Corresponding key** [Marker→] - MKR → OFFSET

## MKRP

**Syntax** MKRP <numeric>

MKRP?

**Description** For the active trace (set with the “TRAC” command on page 444), moves the marker to the specified measurement point. In the coupled marker mode (set with the “MKRCOUP” command on page 341), regardless of the active trace setting, moves the markers on both the A and B traces. If this command is executed as Query, it reads out the measurement point number at the marker position. If the marker function is off, executing this command causes an error and the command is ignored.

### Parameters

	<numeric>
Description	Number of the measurement point to which the marker is moved (the number assigned in order from the left edge assuming that the number of the leftmost measurement point is 1)
Range	1 to the number of points
Resolution	1

If the specified parameter is out of the allowable setting range, the minimum value (if the lower limit of the range is not reached) or the maximum value (if the upper limit of the range is exceeded) is set.

**Query response** {numeric}<newline><^END>

In the continuous marker mode, the number of the largest measurement point that does not exceed the marker position is reads out.

**Corresponding key** No front panel key is available to execute this function.

## MKRPKD

**Syntax** MKRPKD

**Description** For the active trace (set with the “TRAC” command on page 444), sets  $\Delta X$  and  $\Delta Y$  of the peak definition so that the current marker position is recognized as a peak. In other words,  $\Delta X$  and  $\Delta Y$  are respectively set sweep parameter value difference and measurement parameter value difference between the maker and its left adjacent measurement point. Note that, if the  $\Delta$  maker mode is on,  $\Delta X$  and  $\Delta Y$  are respectively set sweep parameter value difference and measurement parameter value difference between the maker and the  $\Delta$  maker.

If the marker function is off, executing this command causes an error and the command is ignored. (No query)

**Corresponding key** [Search] - PEAK - PEAK DEF MENU - MKR → PEAK DELTA

## MKRPRM

**Syntax** MKRPRM <numeric>[HZ|MHZ|V|A]  
MKRPRM?

**Description** For the active trace (set with the “TRAC” command on page 444), moves the marker to the specified sweep parameter value. In the coupled marker mode (set with the “MKRCOUP” command on page 341), regardless of the active trace setting, moves the markers on both the A and B traces. If this command is executed as Query, it reads out the sweep parameter value of the marker position.

If the  $\Delta$  marker mode is on, the marker moves the distance of the specified sweep parameter value relative to the  $\Delta$  marker position. Therefore, specify the position to which you want to move the marker as the difference from the  $\Delta$  marker. The readout, when this command is executed as query, is also the difference value from the  $\Delta$  marker.

If the marker function is off, executing this command causes an error and the command is ignored.

**Parameters**

	<numeric>
Description	Position to which you want to move the marker
Range	“Sweep start value” to “sweep stop value”
Initial value	0
Unit	Varies depending on the sweep parameter (refer to the explanation of unit in “CENT” on page 269).
Resolution	Varies depending on the sweep parameter (refer to the explanation of resolution in “CENT” on page 269).

If the specified parameter is out of the allowable setting range, the minimum value (if the lower limit of the range is not reached) or the maximum value (if the upper limit of the range is exceeded) is set.

**Query response** {numeric}<newline><^END>

**Corresponding key** [Marker]

## MKRREF

**Syntax** MKRREF

**Description** For the active trace (set with the “TRAC” command on page 444), sets the measurement parameter value at the marker position (regardless of on/off of the  $\Delta$  marker mode, the marker readout when the  $\Delta$  marker mode is off) as the reference value. If the marker function is off, executing this command causes an error and the command is ignored. (No query)

**Corresponding key** [Scale Ref] - MKR → REFERENCE

## **MKRSTAR**

<b>Syntax</b>	MKRSTAR
<b>Description</b>	For the active trace (set with the “TRAC” command on page 444), sets the sweep parameter value at the marker position as the sweep range start value. To set the start value of each segment when creating the list sweep table, also use this command. If the marker function is off, executing this command causes an error and the command is ignored. (No query)
<b>Corresponding key</b>	<b>[Marker→] - MKR → START</b>

## **MKRSTOP**

<b>Syntax</b>	MKRSTOP
<b>Description</b>	For the active trace (set with the “TRAC” command on page 444), sets the sweep parameter value at the marker position as the sweep range stop value. To set the stop value of each segment when creating the list sweep table, also use this command. If the marker function is off, executing this command causes an error and the command is ignored. (No query)
<b>Corresponding key</b>	<b>[Marker→] - MKR → STOP</b>

## **MKRTR**

<b>Syntax</b>	MKRTR
<b>Description</b>	For the active trace (set with the “TRAC” command on page 444), sets the range between the marker and the $\Delta$ marker as the partial search range. If the $\Delta$ marker mode is off, executing this command causes an error and the command is ignored. (No query)
<b>Corresponding key</b>	<b>[Search] -SEARCH RANGE MENU - MKR<math>\Delta</math> → SEARCH RNG</b>

## **MKRTRMAX**

<b>Syntax</b>	MKRTRMAX
<b>Description</b>	For the active trace (set with the “TRAC” command on page 444), sets the marker position as the partial search range upper border value. If the marker function is off, executing this command causes an error and the command is ignored. (No query)
<b>Corresponding key</b>	<b>[Search] -SEARCH RANGE MENU - MKR → MAXIMUM</b>



## MKRTRMIN

<b>Syntax</b>	MKRTRMIN
<b>Description</b>	For the active trace (set with the “TRAC” command on page 444), sets the marker position as the partial search range lower border value. If the marker function is off, executing this command causes an error and the command is ignored. (No query)
<b>Corresponding key</b>	[Search] -SEARCH RANGE MENU - MKR → MINIMUM
	<b>MKRVAL?</b>
<b>Syntax</b>	MKRVAL?
<b>Description</b>	For the active trace (set with the “TRAC” command on page 444), reads out the marker position measurement parameter value.
<b>Query response</b>	<p>{numeric}&lt;newline&gt;&lt;^END&gt;</p> <p>If the measurement parameter is a scalar value (for other than COMPLEX Z-Y), the measurement parameter value is read out. If the measurement parameter is a vector value (for COMPLEX Z-Y), the readout is as follows:</p> <ul style="list-style-type: none"> <li>• If the polar chart format is selected, the amplitude is read out.</li> <li>• If the complex plane format is selected, resistance (for trace A) or conductance (for trace B) is read out.</li> </ul>
<b>Corresponding key</b>	No front panel key is available to execute this function.

## MKRXUNIT

**Syntax** MKRXUNIT {STIM|TIME|RFREQ}  
 MKRXUNIT?

**Description** For the active trace (set with the “TRAC” command on page 444), selects the method to display X-axis (horizontal axis) values of the marker. If the sweep parameter is not frequency, executing this command to select the relief time causes an error and the command is ignored.

### Parameters

	Description
STIM (initial value)	Specifies the display in sweep parameter values.
TIME	Specifies the display in time <sup>*1</sup> .
RFREQ	Specifies the display in relief time ( $1/2\pi f$ , f: measurement frequency). (Selectable only when the sweep parameter is frequency.)

\*1. The time spent from the sweep start until measurement completion of each point.

**Query response** {STIM|TIME|RFREQ}<newline><^END>

**Corresponding key** [Utility] - MKR X-AXIS [ ] - {STIMULUS | TIME |  $1/(2\pi F)$ }

## MKRZM

**Syntax** MKRZM

**Description** For the active trace (set with the “TRAC” command on page 444), sets the marker sweep parameter value as the center value of the sweep range, and also sets the span value of the sweep range as the value of (span value before the execution of the command) × (zooming aperture value / 100). The zooming aperture value is set with the “ZMAPER” command on page 450. If the marker function is off, executing this command causes an error and the command is ignored. (No query)

**Corresponding key** [Marker→] - more 1/2 - MKR ZOOM

## NEGL

**Syntax**

NEGL  
 NEGL?

**Description**

Sets the input/output signals of the 24-bit I/O port (data and test PASS/FAIL output) to negative logic (preset state). To specify positive logic, use the “POSL” command on page 392.

**Query response**

{1|0}<newline><^END>

	Description
1	Negative logic is specified.
0	Negative logic is not specified. In other words, positive logic is specified.

**Corresponding key**

No front panel key is available to execute this function.

## NEXNPK?

**Syntax**

NEXNPK?

**Description**

Within the waveform analysis range set with the “ANARANG” command on page 259, searches for the minimum peak having a value more than the value of the negative peak that has been detected at the last execution of this command or the “NPEAK?” command on page 353, and reads out the measurement parameter value and sweep parameter value of the negative peak. If there are several applicable negative peaks, reads out the value of the leftmost negative peak within the analysis range. If no peak exists, 0 is read out.

The negative peak searched for at the execution of this command satisfies the condition set with the “THRR” command on page 439. It is not related to the peak definition in the marker search function. (Query only)

**Query response**

{numeric 1},{numeric 2}<newline><^END>

Readouts are as follows:

- {numeric 1}: Measurement parameter value of the detected negative peak
- {numeric 2}: Sweep parameter value of the detected negative peak

**Corresponding key**

No front panel key is available to execute this function.

## NEXP

<b>Syntax</b>	NEXP
<b>Description</b>	When the measurement results are listed as a result of the execution of the “LISV” command on page 330, displays the next page of the list. To display the previous page, execute the “PREP” command on page 393. (No query)
<b>Corresponding key</b>	[Copy] - <b>SELECT CONTENTS - LIST VALUE - NEXT PAGE</b>
	<b>NEXPK?</b>
<b>Syntax</b>	NEXPK?
<b>Description</b>	<p>Within the waveform analysis range set with the “ANARANG” command on page 259, searches for the maximum peak having a value less than the value of the peak that has been detected at the last execution of this command or the “PEAK?” command on page 386, and reads out the measurement parameter value and the sweep parameter value of the peak. If there are several applicable peaks, reads out the value of the leftmost peak within the analysis range. If no peak exists, 0 is read out.</p> <p>The peak searched for at the execution of this command satisfies the condition set with the “THRR” command on page 439. It is not related to the peak definition in the marker search function. (Query only)</p>
<b>Query response</b>	<p>{numeric 1},{numeric 2}&lt;newline&gt;&lt;^END&gt;</p> <p>Readout value are as follows:</p> <p>{numeric 1}:        Measurement parameter value of the detected peak</p> <p>{numeric 2}:        Sweep parameter value of the detected peak</p>
<b>Corresponding key</b>	No front panel key is available to execute this function.

**NPEAK?**

**Syntax** NPEAK?

**Description** Reads out the measurement parameter value and the sweep parameter value of the minimum negative peak within the waveform analysis range set with the “ANARANG” command on page 259. If there are several minimum negative peaks, reads out the value of the leftmost negative peak within the analysis range. If no negative peak exists, 0 is read out.

The negative peak searched for at the execution of this command satisfies the condition set with the “THRR” command on page 439. It is not related to the peak definition in the marker search function. (Query only)

**Query response** {numeric 1},{numeric 2}<newline><^END>

Readouts are as follows:

- {numeric 1}: Measurement parameter value of the minimum negative peak
- {numeric 2}: Sweep parameter value of the minimum negative peak

**Corresponding key** No front panel key is available to execute this function.

**NUMG**

**Syntax** NUMG

**Description** Performs sweeps the specified times. After the completion of the sweeps, the sweep mode is set to HOLD. (No query)

**Parameters**

	<numeric>
Description	Specified number of times
Range	1 to 999
Resolution	1

If the specified parameter is out of the allowable setting range, the minimum value (if the lower limit of the range is not reached) or the maximum value (if the upper limit of the range is exceeded) is set.

**Query response** {numeric}<newline><^END>

**Corresponding key** [Trigger] - NUMBER OF GROUPS

**OMON**

**Syntax** OMON {ON|OFF|1|0}  
 OMON?

**Description** Toggles on and off the oscillator level monitor function.

**Parameters**

	Description
ON or 1	Turns on the oscillator level monitor function.
OFF or 0 (initial value)	Turns off the oscillator level monitor function.

**Query response** {1|0}<newline><^END>

**Corresponding key** [Display] - OSC MON on OFF

**OPEP**

**Syntax** OPEP

**Description** Lists the measurement parameter, sweep type, number of points, delay time (for each sweep, for each measurement point), sweep range (start value, stop value), and point averaging count on the LCD screen of the 4294A. (No query)

**Corresponding key** [Copy] - SELECT CONTENTS - OPERATING PARAMETERS ►

**OSE**

**Syntax** OSE <numeric>  
 OSE?

**Description** Sets the value of the Operation Status Enable Register.

**Parameters**

	<numeric>
Description	Value of the register
Range	0 to 65535
Initial value	0
Resolution	1

If the specified parameter is out of the allowable setting range, the minimum value (if the lower limit of the range is not reached) or the maximum value (if the upper limit of the range is exceeded) is set.

**Query response** {numeric}<newline><^END>

**Corresponding key** No front panel key is available to execute this function.

## OSER?

- Syntax** OSER?
- Description** Reads out the value of the Operation Status Event Register. (Query only)
- Corresponding key** No front panel key is available to execute this function.

## OSNT

- Syntax** OSNT <numeric>  
OSNT?
- Description** Sets the value of the Negative Transition Filter of the Operation Status Register.
- Parameters**

	<numeric>
Description	Value of the filter
Range	0 to 65535
Initial value	0
Resolution	1

If the specified parameter is out of the allowable setting range, the minimum value (if the lower limit of the range is not reached) or the maximum value (if the upper limit of the range is exceeded) is set.

- Query response** {numeric}<newline><^END>
- Corresponding key** No front panel key is available to execute this function.

**OSPT**

**Syntax** OSPT <numeric>  
OSPT?

**Description** Sets the value of the Positive Transition Filter of the Operation Status Register.

**Parameters**

	<numeric>
Description	Value of the filter
Range	0 to 65535
Initial value	0
Resolution	1

If the specified parameter is out of the allowable setting range, the minimum value (if the lower limit of the range is not reached) or the maximum value (if the upper limit of the range is exceeded) is set.

**Query response** {numeric}<newline><^END>

**Corresponding key** No front panel key is available to execute this function.

**OSR?**

**Syntax** OSR?

**Description** Reads out the value of the Operation Status Condition Register. (Query only)

**Corresponding key** No front panel key is available to execute this function.

**OUT1{H|L}**

**Syntax** OUT1 {H|L}

**Description** Sets OUTPUT1 of the 24-bit I/O port to HIGH (or LOW). (No query)

**Corresponding key** No front panel key is available to execute this function.

**OUT1ENV{H|L}**

**Syntax** OUT1ENV{H|L}  
OUT1ENV{H|L}?

**Description** Makes the setting so that OUTPUT1 goes to HIGH (or LOW) when a pulse is inputted to INPUT1 of the 24-bit I/O port.

**Corresponding key** No front panel key is available to execute this function.



### **OUT2{H|L}**

- Syntax**                   OUT2{H|L}
- Description**             Sets the OUTPUT2 of the 24-bit I/O port to HIGH (or LOW). (No query)
- Corresponding key**     No front panel key is available to execute this function.

### **OUT2ENV{H|L}**

- Syntax**                   OUT2ENV{H|L}  
 OUT2ENV{H|L}?
- Description**             Makes the setting so that OUTPUT2 goes to HIGH (or LOW) when a pulse is inputted to INPUT1 of the 24-bit I/O port.
- Corresponding key**     No front panel key is available to execute this function.

### **OUT8IO**

- Syntax**                   OUT8IO <numeric>
- Description**             Outputs data to OUT0 to OUT7 of the 8-bit I/O port. Data is outputted as 8-bit binary, assuming that OUT0 is LSB and OUT7 is MSB. This command has the same function as the WRITEIO 15,0 command of Instrument BASIC. (Query only)

**Parameters**

	<b>&lt;numeric&gt;</b>
Description	Output data
Range	0 to 255
Resolution	1

If the specified parameter is out of the allowable setting range, the minimum value (if the lower limit of the range is not reached) or the maximum value (if the upper limit of the range is exceeded) is set.

- Corresponding key**     No front panel key is available to execute this function.

## **OUTAIO**

**Syntax** OUTAIO <numeric>

**Description** Outputs data to output port A (A0 to A7) of the 24-bit I/O port. Data is outputted as 8-bit binary, assuming that A0 is LSB and A7 is MSB. This command has the same function as the WRITEIO 16,0 command of Instrument BASIC. (No query)

**Parameters**

	<b>&lt;numeric&gt;</b>
Description	Output data
Range	0 to 255
Resolution	1

If the specified parameter is out of the allowable setting range, the minimum value (if the lower limit of the range is not reached) or the maximum value (if the upper limit of the range is exceeded) is set.

**Corresponding key** No front panel key is available to execute this function.

## **OUTBIO**

**Syntax** OUTBIO <numeric>

**Description** Outputs data to output port B (B0 to B7) of the 24-bit I/O port. Data is outputted as 8-bit binary, assuming that B0 is LSB and B7 is MSB. This command has the same function as the WRITEIO 16,1 command of Instrument BASIC. (No query)

**Parameters**

	<b>&lt;numeric&gt;</b>
Description	Output data
Range	0 to 255
Resolution	1

If the specified parameter is out of the allowable setting range, the minimum value (if the lower limit of the range is not reached) or the maximum value (if the upper limit of the range is exceeded) is set.

**Corresponding key** No front panel key is available to execute this function.

## OUTCIO

**Syntax** OUTCIO <numeric>

**Description** If input/output port C of the 24-bit I/O port has been set to an output port (by the execution of the “COUT” command on page 275), outputs data to port C (C0 to C3). Data is outputted as 4-bit binary, assuming that C0 is LSB and C3 is MSB. If port C is set to an input port, executing this command causes an error and the command is ignored. This command has the same function as the WRITEIO 16,2 command of Instrument BASIC. (No query)

**Parameters**

	<numeric>
Description	Output data
Range	0 to 15
Resolution	1

If the specified parameter is out of the allowable setting range, the minimum value (if the lower limit of the range is not reached) or the maximum value (if the upper limit of the range is exceeded) is set.

**Corresponding key** No front panel key is available to execute this function.

## OUTDIO

**Syntax** OUTDIO <numeric>

**Description** If input/output port D of the 24-bit I/O port has been set to an output port (by the execution of the “DOUT” command on page 297), outputs data to port D (D0 to D3). Data is outputted as 4-bit binary, assuming that D0 is LSB and D3 is MSB. If port D is set to an input port, executing this command causes an error and the command is ignored. This command has the same function as the WRITEIO 16,3 command of Instrument BASIC. (No query)

**Parameters**

	<numeric>
Description	Output data
Range	0 to 15
Resolution	1

If the specified parameter is out of the allowable setting range, the minimum value (if the lower limit of the range is not reached) or the maximum value (if the upper limit of the range is exceeded) is set.

**Corresponding key** No front panel key is available to execute this function.

16. GPIB  
Command Reference  
(O - R)

**OUTEIO**

**OUTEIO**

**Syntax** OUTEIO <numeric>

**Description** If input/output port E (port C + port D) of the 24-bit I/O port has been set to an output port (by the execution of the “COUT” command on page 275 and “DOUT” command on page 297), outputs data to port E. Data is outputted as 8-bit binary, assuming that C0 is LSB and D3 is MSB. If port C or port D is set to an input port, executing this command causes an error and the command is ignored. This command has the same function as the WRITEIO 16,4 command of Instrument BASIC. (No query)

**Parameters**

	<b>&lt;numeric&gt;</b>
Description	Output data
Range	0 to 255
Resolution	1

If the specified parameter is out of the allowable setting range, the minimum value (if the lower limit of the range is not reached) or the maximum value (if the upper limit of the range is exceeded) is set.

**Corresponding key** No front panel key is available to execute this function.

**OUTFIO**

**Syntax** OUTFIO <numeric>

**Description** Outputs data to output port F (port A + port B) of the 24-bit I/O port. Data is outputted as 16-bit binary, assuming that A0 is LSB and B7 is MSB. This command has the same function as the WRITEIO 16,5 command of Instrument BASIC. (No query)

**Parameters**

	<b>&lt;numeric&gt;</b>
Description	Output data
Range	0 to 65535
Resolution	1

If the specified parameter is out of the allowable setting range, the minimum value (if the lower limit of the range is not reached) or the maximum value (if the upper limit of the range is exceeded) is set.

**Corresponding key** No front panel key is available to execute this function.

## OUTGIO

**Syntax** OUTGIO <numeric>

**Description** Outputs data to output port G (port A + port B + port C) of the 24-bit I/O port. Data is outputted as 20-bit binary, assuming that A0 is LSB and C3 is MSB. If port C is set to an input port, executing this command causes an error and the command is ignored. This command has the same function as the WRITEIO 16,6 command of Instrument BASIC. (No query)

**Parameters**

	<numeric>
Description	Output data
Range	0 to 1048575
Resolution	1

If the specified parameter is out of the allowable setting range, the minimum value (if the lower limit of the range is not reached) or the maximum value (if the upper limit of the range is exceeded) is set.

**Corresponding key** No front panel key is available to execute this function.

## OUTHIO

**Syntax** OUTHIO <numeric>

**Description** Outputs data to output port H (port A + port B + port C + port D) of the 24-bit I/O port. Data is outputted as 24-bit binary, assuming that A0 is LSB and D3 is MSB. If port C or port D is set to an input port, executing this command causes an error and the command is ignored. This command has the same function as the WRITEIO 16,7 command of Instrument BASIC. (No query)

**Parameters**

	<numeric>
Description	Output data
Range	0 to 16777215
Resolution	1

If the specified parameter is out of the allowable setting range, the minimum value (if the lower limit of the range is not reached) or the maximum value (if the upper limit of the range is exceeded) is set.

**Corresponding key** No front panel key is available to execute this function.

16. GPiB  
 Command Reference  
 (O - R)

## **OUTPCALC{1-3}?**

<b>Syntax</b>	OUTPCALC{1-3}?
<b>Description</b>	Reads out the OPEN/SHORT/LOAD data for user calibration. Use the “OUTPCALC1” command to read out the OPEN data (G-B); the “OUTPCALC2” command, the SHORT data (R-X); the “OUTPCALC3” command, the LOAD data (R-X). (Query only)
<b>Query response</b>	{numeric 1},{numeric 2},...,{numeric NOP×2-1},{numeric NOP×2}<newline><^END> Reads out the real part and the imaginary part of each measurement point value (complex number) separately. Where, NOP is the number of points (for user measurement points) or 100 (for fixed measurement points), and n is an integer between 1 and NOP. {numeric n×2-1}: Value of the n-th measurement point (real part) {numeric n×2}: Value of the n-th measurement point (imaginary part)
<b>Corresponding key</b>	No front panel key is available to execute this function.

## **OUTPCERR?**

<b>Syntax</b>	OUTPCERR?
<b>Description</b>	If the sweep parameter is frequency and the measurement parameter is $ Z -\theta$ , within the waveform analysis range specified with the “ANARANG” command on page 259, obtains the parameters of a ceramic resonator and reads out the results. If the sweep parameter is not frequency or if the measurement parameter is not $ Z -\theta$ , executing this command causes an error and all readouts are 0. (Query only)
<b>Query response</b>	{numeric 1},{numeric 2},{numeric 3},{numeric 4},{numeric 5},{numeric 6},{numeric 7}<newline><^END> The readouts are as follows: {numeric 1}: Value of $Z_r$ (resonant impedance). {numeric 2}: Value of $f_r$ (resonant frequency). {numeric 3}: Value of $Z_a$ (anti-resonant impedance). {numeric 4}: Value of $f_a$ (anti-resonant frequency). {numeric 5}: Value of $Rpl_1$ (the maximum value of the left-side ripple (the sweep parameter difference between the peak and the left adjacent negative peak) within the range to the left of the resonant point within the waveform analysis range). {numeric 6}: Value of $Rpl_2$ (the maximum value of the right-side ripple (the sweep parameter difference between the peak and the right adjacent negative peak) within the range between the resonant point and the anti-resonant point within the waveform analysis range). {numeric 7}: $Rpl_3$ (the maximum value of the left-side ripple within the range to the right of the resonant point within the waveform analysis range).

This command defines the minimum negative peak as the resonant point and the maximum peak as the anti-resonant point. For parameters not obtained because no peak and negative peak are detected, 0 is read out.

The peak and negative peak used at the execution of this command satisfies the condition set with the “THRR” command on page 439. They are not related to the peak definition in the marker search function.

**Figure 16-4**

**Analyzed parameters of a ceramic resonator**

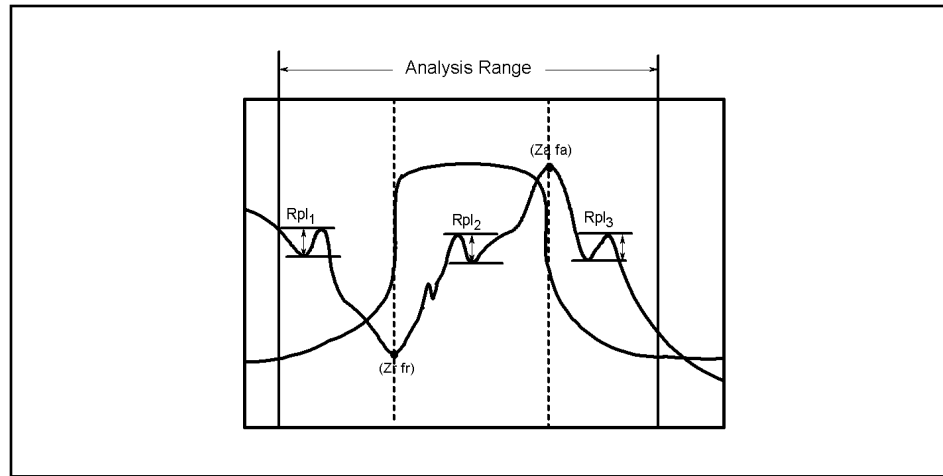

4294ape004

**Corresponding key**

No front panel key is available to execute this function.

**OUTPCOMC{1-3}?**

**Syntax**

OUTPCOMC{1-3}?

**Description**

Reads out OPEN/SHORT/LOAD data for fixture compensation. Use the “OUTPCOMC1” command to read out OPEN data (G-B); the “OUTPCOMC2” command, SHORT data (R-X); the “OUTPCOMC3” command, LOAD data (R-X). (Query only)

**Query response**

{numeric 1},{numeric 2},..., {numeric NOP×2-1}, {numeric NOP×2}<newline><^END>

Reads out the real part and imaginary part of each measurement point value (complex number) separately. Where, NOP is the number of points (for user measurement points) or 100 (for fixed measurement points), and n is an integer between 1 and NOP.

{numeric n×2-1}: Value of the n-th measurement point (real part).

{numeric n×2}: Value of the n-th measurement point (imaginary part).

**Corresponding key**

No front panel key is available to execute this function.

16. GPIB  
Command Reference  
(O - R)

**OUTPDATA?**

**OUTPDATA?**

**Syntax**                   OUTPDATA?

**Description**            Reads out the values (complex number) of all measurement points in a data array (refer to “Internal data arrays” on page 81). (Query only)

**Query response**        {numeric 1},{numeric 2},...,{numeric NOP×2-1},{numeric NOP×2}<newline><^END>

Reads out the real part and imaginary part of each measurement point value (complex number) separately. Where, NOP is the number of points, and n is an integer between 1 and NOP.

{numeric n×2-1}:   Measurement parameter value of the n-th measurement point (real part).

{numeric n×2}:     Measurement parameter value of the n-th measurement point (imaginary part).

**Corresponding key**     No front panel key is available to execute this function.

**OUTPDATAP?**

**Syntax**                   OUTPDATAP? <numeric 1>

**Description**            Reads out the value (complex number) of the specified measurement point in a data array (refer to “Internal data arrays” on page 81). (Query only)

**Parameters**

	<b>&lt;numeric 1&gt;</b>
Description	Number of the measurement point you want to read out (the number assigned in order from the left edge assuming that the number of the leftmost measurement point is 1)
Range	1 to the number of points
Resolution	1

If the specified parameter is out of the allowable setting range, the minimum value (if the lower limit of the range is not reached) or the maximum value (if the upper limit of the range is exceeded) is set.

**Query response**        {numeric 2},{numeric 3}<newline><^END>

The real part and imaginary part are read out separately as shown below.

{numeric 2}:        Measurement parameter value of the specified measurement point (real part).

{numeric 3}:        Measurement parameter value of the specified measurement point (imaginary part).

**Corresponding key**     No front panel key is available to execute this function.



## OUTPDC?

- Syntax**                   OUTPDC?
- Description**               In the dc bias level monitor function, if monitoring voltage or current is enabled (VOLT or CURR has been specified with the “BMON” command on page 264), reads out the dc bias level voltage or current monitor value at all measurement points. (Query only)
- Query response**           {numeric 1},{numeric 2},...,{numeric NOP}<newline><^END>  
 Where, NOP is the number of points.  
 If the oscillator level monitor function is set to off, the readout are invalid.
- Corresponding key**       No front panel key is available to execute this function.

## OUTPDCP?

- Syntax**                   OUTPDCP? <numeric 1>
- Description**               In the dc bias level monitor function, if monitoring voltage or current is enabled (VOLT or CURR has been specified with the “BMON” command on page 264), reads out the dc bias level voltage or current monitor value of the specified measurement point. (Query only)

**Parameters**

	<b>&lt;numeric 1&gt;</b>
Description	Number of the measurement point you want to read out (the number assigned in order from the left edge assuming that the number of the leftmost measurement point is 1)
Range	1 to the number of points
Resolution	1

If the specified parameter is out of the allowable setting range, the minimum value (if the lower limit of the range is not reached) or the maximum value (if the upper limit of the range is exceeded) is set.

- Query response**           {numeric 2}<newline><^END>

	<b>{numeric 2}</b>
Description	Voltage or current monitor value of the dc bias level

If the oscillator level monitor function is set to off, the readout is invalid.

- Corresponding key**       No front panel key is available to execute this function.

16. GPiB  
 Command Reference  
 (O - R)

## **OUTPDMKR?**

<b>Syntax</b>	OUTPDMKR?
<b>Description</b>	For the active trace (set with the “TRAC” command on page 444), reads out the measurement parameter value and sweep parameter value of the $\Delta$ marker position. If the $\Delta$ marker mode is off, executing this command causes an error and the readouts are invalid. (Query only)
<b>Query response</b>	<p>{numeric 1},{numeric 2},{numeric 3}&lt;newline&gt;&lt;^END&gt;</p> <p>Readouts are as follows:</p> <p>{numeric 1}:      Readout of the measurement parameter value at the <math>\Delta</math> marker position. If the measurement parameter is a scalar value (for other than COMPLEX Z-Y), the measurement parameter value is read out. If the measurement parameter is a vector value (for COMPLEX Z-Y), the readout is as follows:</p> <ul style="list-style-type: none"><li>• If the polar chart format is selected, the amplitude is read out.</li><li>• If the complex plane format is selected, resistance (for trace A) or conductance (for trace B) is read out.</li></ul> <p>{numeric 2}:      Subsidiary readout of the measurement parameter value at the <math>\Delta</math> marker position. If the measurement parameter is a scalar value (for other than COMPLEX Z-Y), 0 is always read out. If the measurement parameter is a vector value (for COMPLEX Z-Y), the readout is as follows:</p> <ul style="list-style-type: none"><li>• If the polar chart format is selected, the phase is read out.</li><li>• If the complex plane format is selected, reactance (for trace A) or susceptance (for trace B) is reads out.</li></ul> <p>{numeric 3}:      Sweep parameter value at the <math>\Delta</math> marker position.</p>
<b>Corresponding key</b>	No front panel key is available to execute this function.

## OUTPDTRC?

<b>Syntax</b>	OUTPDTRC?
<b>Description</b>	Reads out the values of all measurement points in a data trace array (refer to “Internal data arrays” on page 81). (Query only)
<b>Query response</b>	<p>{numeric 1},{numeric 2},...,{numeric NOP×2-1},{numeric NOP×2}&lt;newline&gt;&lt;^END&gt;</p> <p>Reads out the readout and subsidiary readout of the measurement parameter value of each measurement point as shown below. Where, NOP is the number of points, and n is an integer between 1 and NOP.</p> <p>{numeric n×2-1}: Readout of the n-th measurement point. If the measurement parameter is a scalar value (for other than COMPLEX Z-Y), the measurement parameter value is read out. If the measurement parameter is a vector value (for COMPLEX Z-Y), resistance (for trace A) or conductance (for trace B) is read out.</p> <p>{numeric n×2}: Subsidiary readout of the n-th measurement point. If the measurement parameter is a scalar value (for other than COMPLEX Z-Y), 0 is always read out. If the measurement parameter is a vector value (for COMPLEX Z-Y), reactance (for trace A) or susceptance (for trace B) is reads out.</p>
<b>Corresponding key</b>	No front panel key is available to execute this function.

## OUTPDTRCP?

**Syntax** OUTPDTRCP? <numeric 1>

**Description** Reads out the value of the specified measurement point in a data trace array (refer to “Internal data arrays” on page 81). (Query only)

**Parameters**

	<b>&lt;numeric 1&gt;</b>
Description	Number of the measurement point you want to read out (the number assigned in order from the left edge assuming that the number of the leftmost measurement point is 1)
Range	1 to the number of points
Resolution	1

If the specified parameter is out of the allowable setting range, the minimum value (if the lower limit of the range is not reached) or the maximum value (if the upper limit of the range is exceeded) is set.

**Query response** {numeric 2}, {numeric 3}<newline><^END>

Reads out the readout and subsidiary readout of the measurement parameter value as shown below.

{numeric 2}: Readout of the specified measurement point. If the measurement parameter is a scalar value (for other than COMPLEX Z-Y), the measurement parameter value is read out. If the measurement parameter is a vector value (for COMPLEX Z-Y), resistance (for trace A) or conductance (for trace B) is read out.

{numeric 3}: Subsidiary readout of the specified measurement point. If the measurement parameter is a scalar value (for other than COMPLEX Z-Y), 0 is always read out. If the measurement parameter is a vector value (for COMPLEX Z-Y), reactance (for trace A) or susceptance (for trace B) is read out.

**Corresponding key** No front panel key is available to execute this function.

## OUTPERRO?

- Syntax** OUTPERRO?
- Description** Reads out the oldest error among errors stored in the error queue of the 4294A. The size of the error queue is 10. (Query only)
- Query response** {numeric},{string}<newline><^END>

	{numeric}	{string}
Description	Error number	Error message (string with double quotation marks (""))

If no error is stored in the error queue, the read-out error number is 0 and the error message is "No error."

- Corresponding key** No front panel key is available to execute this function.

## OUTPFAIP?

- Syntax** OUTPFAIP?
- Description** For the active trace (set with the "TRAC" command on page 444), reads out the number of points whose limit test result is FAIL. (Query only)
- Query response** {numeric}<newline><^END>
- Corresponding key** No front panel key is available to execute this function.

## OUTPIAC?

- Syntax** OUTPIAC?
- Description** When the oscillator level monitor function is set to on (set to ON with "OMON" command on page 354), reads out the oscillator current level monitor values of all measurement points. (Query only)
- Query response** {numeric 1},{numeric 2},..., {numeric NOP}<newline><^END>
- Where, NOP is the number of points.
- If the oscillator level monitor function is set to off, the readouts are invalid.
- Corresponding key** No front panel key is available to execute this function.

**OUTPIACP?**

**OUTPIACP?**

**Syntax** OUTPIACP? <numeric 1>

**Description** When the oscillator level monitor function is set to on (set to ON with “OMON” command on page 354), reads out the oscillator current level monitor value of the specified measurement point. (Query only)

**Parameters**

	<b>&lt;numeric 1&gt;</b>
Description	Number of the measurement point you want to read out (the number assigned in order from the left edge assuming that the number of the leftmost measurement point is 1)
Range	1 to the number of points
Resolution	1

If the specified parameter is out of the allowable setting range, the minimum value (if the lower limit of the range is not reached) or the maximum value (if the upper limit of the range is exceeded) is set.

**Query response** {numeric 2}<newline><^END>

	<b>{numeric 2}</b>
Description	Current monitor value of the oscillator level

If the oscillator level monitor function is set to off, the readout is invalid.

**Corresponding key** No front panel key is available to execute this function.

**OUTPINPCIO?**

**Syntax** OUTPINPCIO?

**Description** When input/output port C of the 24-bit I/O port is set to an input port (by the execution of the “CIN” command on page 270), 4-bit data is inputted into the 4294A through port C (C0 to C3) and the data is read out to the external controller. If port C is set to an output port, executing this command causes an error and the command is ignored. This command has the same function as the READIO(16,2) command of Instrument BASIC.

**Query response** {numeric}<newline><^END>

	<b>{numeric}</b>
Description	Decimal value for the 4-bit binary data inputted from C0-C3, assuming that C0 is LSB and C3 is MSB.

**Corresponding key** No front panel key is available to execute this function.

## OUTPINPDIO?

**Syntax** OUTPINPDIO?

**Description** When input/output port D of the 24-bit I/O port is set to an input port (by the execution of the “DIN” command on page 287), 4-bit data is inputted into the 4294A through port D (D0 to D3) and the data is read out to the external controller. If port D is set to an output port, executing this command causes an error and the command is ignored. This command has the same function as the READIO(16,3) command of Instrument BASIC.

**Query response** {numeric}<newline><^END>

	<b>{numeric}</b>
Description	Decimal value for the 4-bit binary data inputted from D0-D3, assuming that D0 is LSB and D3 is MSB.

**Corresponding key** No front panel key is available to execute this function.

## OUTPINPEIO?

**Syntax** OUTPINPEIO?

**Description** When input/output port E (port C + port D) of the 24-bit I/O port is set to an input port (by the execution of the “CIN” command on page 270 and “DIN” command on page 287), 8-bit data is inputted into the 4294A through port E (C0-D3) and the data is read out to the external controller. If port E is set to an output port, executing this command causes an error and the command is ignored. This command has the same function as the READIO(16,4) command of Instrument BASIC.

**Query response** {numeric}<newline><^END>

	<b>{numeric}</b>
Description	Decimal value for the 8-bit binary data inputted from C0-D3, assuming that C0 is LSB and D3 is MSB.

**Corresponding key** No front panel key is available to execute this function.

**OUTPLIMF?****OUTPLIMF?**

<b>Syntax</b>	OUTPLIMF?
<b>Description</b>	For the active trace (set with the “TRAC” command on page 444), reads out the limit test results of measurement points that failed the test (FAIL). (Query only)
<b>Query response</b>	<p>{numeric 1},{numeric 2},..., {numeric F_NOP×4}&lt;newline&gt;&lt;^END&gt;</p> <p>Where, F_NOP is the number of points that failed the test, which can be obtained using the “OUTPFAIP?” command on page 369. As shown below, for each measurement point, NOP sets of values (sweep parameter value, test result, upper limit, and lower limit) are read out in this order (total of F_NOP×4 values).</p> <p style="padding-left: 40px;">{numeric n×4+1}: Sweep parameter value</p> <p style="padding-left: 40px;">{numeric n×4+2}: Limit test result (always 0)</p> <p style="padding-left: 40px;">{numeric n×4+3}: Upper border value of the limit</p> <p style="padding-left: 40px;">{numeric n×4+4}: Lower border value of the limit</p> <p>Where, n is an integer between 0 and F_NOP - 1.</p> <p>Note that if there is no failed measurement point, only 1 piece of data, whose value is 1, is read out.</p>
<b>Corresponding key</b>	No front panel key is available to execute this function.

**OUTPLIML?**

<b>Syntax</b>	OUTPLIML?
<b>Description</b>	For the active trace (set with the “TRAC” command on page 444), reads out the limit test results of all measurement points. (Query only)
<b>Query response</b>	<p>{numeric 1},{numeric 2},..., {numeric NOP×4}&lt;newline&gt;&lt;^END&gt;</p> <p>Where, NOP is the number of points specified using the “POIN” command on page 390. As shown below, for each measurement point, NOP sets of values (sweep parameter value, test result, upper limit, and lower limit) are read out in this order (total of NOP×4 values).</p> <p style="padding-left: 40px;">{numeric n×4+1}: Sweep parameter value</p> <p style="padding-left: 40px;">{numeric n×4+2}: Limit test result</p> <p style="padding-left: 80px;">0: FAIL</p> <p style="padding-left: 80px;">1: PASS</p> <p style="padding-left: 80px;">-1: Test was off.</p> <p style="padding-left: 40px;">{numeric n×4+3}: Upper border value of the limit</p> <p style="padding-left: 40px;">{numeric n×4+4}: Lower border value of the limit</p> <p>Where, n is an integer between 0 and NOP-1.</p>
<b>Corresponding key</b>	No front panel key is available to execute this function.



## OUTPLIMM?

<b>Syntax</b>	OUTPLIMM?
<b>Description</b>	For the active trace (set with the “TRAC” command on page 444), reads out the limit test result of measurement point of the marker position. If the marker function is off, executing this command causes an error and invalid values are read out. (Query only)
<b>Query response</b>	{numeric 1},{numeric 2},{numeric 3},{numeric 4}<newline><^END> The readouts are as follows: {numeric 1}: Sweep parameter value {numeric 2}: Limit test result 0: FAIL 1: PASS -1: Test was off. {numeric 3}: Upper border value of the limit {numeric 4}: Lower border value of the limit
<b>Corresponding key</b>	No front panel key is available to execute this function.

## OUTPMAx?

<b>Syntax</b>	OUTPMAx?
<b>Description</b>	Reads out the maximum measurement parameter value and the sweep parameter value at the position, within the waveform analysis range set with the “ANARANG” command on page 259. If there are several measurement points of the maximum measurement parameter value, reads out the value of the leftmost measurement point within the analysis range. (Query only)
<b>Query response</b>	{numeric 1},{numeric 2}<newline><^END> Readouts are as follows: {numeric 1}: Maximum measurement parameter value. {numeric 2}: Sweep parameter value at the position of the maximum measurement parameter value.
<b>Corresponding key</b>	No front panel key is available to execute this function.

**OUTPMEMO?**

**OUTPMEMO?**

**Syntax** OUTPMEMO?

**Description** Reads out the values (complex number) of all measurement points in the memory array (refer to “Internal data arrays” on page 81). (Query only)

**Query response** {numeric 1},{numeric 2},...,{numeric NOP×2-1},{numeric NOP×2}<newline><^END>  
 Reads out the real part and imaginary part of each measurement point value (complex number) separately. Where, NOP is the number of points, and n is an integer between 1 and NOP.  
 {numeric n×2-1}: Measurement parameter value of the n-th measurement point (real part).  
 {numeric n×2}: Measurement parameter value of the n-th measurement point (imaginary part).

**Corresponding key** No front panel key is available to execute this function.

**OUTPMEMOP?**

**Syntax** OUTPMEMOP? <numeric 1>

**Description** Reads out the value (complex number) of the specified measurement point in the memory array (refer to “Internal data arrays” on page 81). (Query only)

**Parameters**

	<b>&lt;numeric 1&gt;</b>
Description	Number of the measurement point you want to read out (the number assigned in order from the left edge assuming that the number of the leftmost measurement point is 1)
Range	1 to the number of points
Resolution	1

If the specified parameter is out of the allowable setting range, the minimum value (if the lower limit of the range is not reached) or the maximum value (if the upper limit of the range is exceeded) is set.

**Query response** {numeric 2},{numeric 3}<newline><^END>  
 The real part and imaginary part are read out separately as shown below.  
 {numeric 2}: Measurement parameter value of the specified measurement point (real part).  
 {numeric 3}: Measurement parameter value of the specified measurement point (imaginary part).

**Corresponding key** No front panel key is available to execute this function.

## OUTPMIN?

<b>Syntax</b>	OUTPMIN?
<b>Description</b>	Reads out the value of the minimum measurement parameter value within the waveform analysis range set with the “ANARANG” command on page 259 and the sweep parameter value at the position. If there are several measurement points of the minimum measurement parameter value, reads out the value of the leftmost measurement point within the analysis range.(Query only)
<b>Query response</b>	{numeric 1},{numeric 2}<newline><^END> Readouts are as follows: {numeric 1}: Minimum measurement parameter value. {numeric 2}: Sweep parameter value at the position of the minimum measurement parameter value
<b>Corresponding key</b>	No front panel key is available to execute this function.

## OUTPMINMAX?

<b>Syntax</b>	OUTPMINMAX?
<b>Description</b>	Within the waveform analysis range set with the “ANARANG” command on page 259, reads out the maximum measurement parameter value and the sweep parameter value at the position and the minimum measurement parameter value and the sweep parameter value at the position. If there are several measurement points of the minimum or maximum measurement parameter value, reads out the value of the leftmost measurement point within the analysis range. (Query only)
<b>Query response</b>	{numeric 1},{numeric 2},{numeric 3},{numeric 4}<newline><^END> Readouts are as follows: {numeric 1}: Minimum measurement parameter value. {numeric 2}: Sweep parameter value at the position of the minimum measurement parameter value. {numeric 3}: Maximum measurement parameter value. {numeric 4}: Sweep parameter value at the position of the maximum measurement parameter value.
<b>Corresponding key</b>	No front panel key is available to execute this function.

**OUTPMKR?**

**OUTPMKR?**

<b>Syntax</b>	OUTPMKR?
<b>Description</b>	For the active trace (set with the “TRAC” command on page 444), reads out the measurement parameter value and sweep parameter value at the marker position. If the marker function is off, executing this command causes an error and the read out values are invalid.(Query only)
<b>Query response</b>	<p>{numeric 1},{numeric 2},{numeric 3}&lt;newline&gt;&lt;&lt;^END&gt;</p> <p>Readouts are as follows:</p> <p>{numeric 1}:        Readout of the measurement parameter value at the marker position. If the measurement parameter is a scalar value (for other than COMPLEX Z-Y), the measurement parameter value is read out. If the measurement parameter is a vector value (for COMPLEX Z-Y), the readout is as follows:</p> <ul style="list-style-type: none"> <li>• If the polar chart format is selected, the amplitude is read out.</li> <li>• If the complex plane format is selected, resistance (for trace A) or conductance (for trace B) is read out.</li> </ul> <p>{numeric 2}:        Subsidiary readout of the measurement parameter value at the marker position. If the measurement parameter is a scalar value (for other than COMPLEX Z-Y), 0 is always read out. If the measurement parameter is a vector value (for COMPLEX Z-Y), the readout is as follows:</p> <ul style="list-style-type: none"> <li>• If the polar chart format is selected, the phase is read out.</li> <li>• If the complex plane format is selected, reactance (for trace A) or susceptance (for trace B) is read out.</li> </ul> <p>{numeric 3}:        Sweep parameter value at the marker position.</p>
<b>Corresponding key</b>	No front panel key is available to execute this function.

## OUTPMSTA?

**Syntax** OUTPMSTA?

**Description** For the active trace (set with the “TRAC” command on page 444), calculates the statistics (mean value, standard deviation, and difference value between the maximum value and the minimum value) within the search range on the trace selected as the marker use target trace (set with the “MKRO” command on page 345), and reads out the result. (Query only)

**Query response** {numeric 1},{numeric 2},{numeric 3}<newline><^END>

	{numeric 1}	{numeric 2}	{numeric 3}
Description	Mean value	Standard deviation	Difference value between the maximum value and the minimum value

**Corresponding key** No front panel key is available to execute this function.

## OUTPMTRC?

**Syntax** OUTPMTRC?

**Description** Reads out the values of all measurement points in the memory trace array (refer to “Internal data arrays” on page 81). (Query only)

**Query response** {numeric 1},{numeric 2},...,{numeric NOP×2-1},{numeric NOP×2}<newline><^END>

Reads out the readout and subsidiary readout of the measurement parameter value of each measurement point as shown below. Where, NOP is the number of points, and n is an integer between 1 and NOP.

{numeric n×2-1}: Readout of the n-th measurement point. If the measurement parameter is a scalar value (for other than COMPLEX Z-Y), the measurement parameter value is read out. If the measurement parameter is a vector value (for COMPLEX Z-Y), resistance (for trace A) or conductance (for trace B) is read out.

{numeric n×2}: Subsidiary readout of the n-th measurement point. If the measurement parameter is a scalar value (for other than COMPLEX Z-Y), 0 is always read out. If the measurement parameter is a vector value (for COMPLEX Z-Y), reactance (for trace A) or susceptance (for trace B) is read out.

**Corresponding key** No front panel key is available to execute this function.

16. GPIB  
 Command Reference  
 (O - R)

## OUTPMTRCP?

**Syntax** OUTPMTRCP? <numeric 1>

**Description** Reads out the value of the specified measurement point in the memory trace array (“Internal data arrays” on page 81). (Query only)

**Parameters**

	<numeric 1>
Description	Number of the measurement point you want to read out (the number assigned in order from the left edge assuming that the number of the leftmost measurement point is 1)
Range	1 to the number of points
Resolution	1

If the specified parameter is out of the allowable setting range, the minimum value (if the lower limit of the range is not reached) or the maximum value (if the upper limit of the range is exceeded) is set.

**Query response** {numeric 2}, {numeric 3}<newline><^END>

Reads out the readout and subsidiary readout of the measurement parameter value as shown below..

{numeric 2}: Readout of the specified measurement point. If the measurement parameter is a scalar value (for other than COMPLEX Z-Y), the measurement parameter value is read out. If the measurement parameter is a vector value (for COMPLEX Z-Y), resistance (for trace A) or conductance (for trace B) is read out.

{numeric 3}: Subsidiary readout of the specified measurement point. If the measurement parameter is a scalar value (for other than COMPLEX Z-Y), 0 is always read out. If the measurement parameter is a vector value (for COMPLEX Z-Y), reactance (for trace A) or susceptance (for trace B) is read out.

**Corresponding key** No front panel key is available to execute this function.

## OUTPMWID?

<b>Syntax</b>	OUTPMWID?
<b>Description</b>	For the active trace (set with the “TRAC” command on page 444), if the trace bandwidth analysis function is on (specified to ON with the “WIDT” command on page 448), reads out the result of the bandwidth search. (Query only)
<b>Query response</b>	<p>{numeric 1},{numeric 2},{numeric 3},{numeric 4},{numeric 5},{numeric 6}&lt;newline&gt;&lt;^END&gt;</p> <p>The readouts are as follows:</p> <p>{numeric 1}: Bandwidth.</p> <p>{numeric 2}: Center frequency.</p> <p>{numeric 3}: Quality factor.</p> <p>{numeric 4}: Measurement parameter value of the maker position.</p> <p>{numeric 5}: Value of the left cutoff point sweep parameter value minus the center value of the sweep range.</p> <p>{numeric 6}: Value of the right cutoff point sweep parameter value minus the center value of the sweep range.</p> <p>If the trace bandwidth analysis function is off, the readouts are invalid.</p>
<b>Corresponding key</b>	No front panel key is available to execute this function.

## OUTPRESO?

**Syntax**

OUTPRESO?

**Description**

If the sweep parameter is frequency and the measurement parameter is  $|Z|-\theta$ , within the waveform analysis range specified with the “ANARANG” command on page 259, analyzes the resonant point and reads out the result. If the sweep parameter is not frequency or if the measurement parameter is not  $|Z|-\theta$ , executing this command causes an error and all readouts are 0. (Query only)

**Query response**

{numeric 1},{numeric 2},{numeric 3},{numeric 4}<newline><^END>

The readouts are as follows:

{numeric 1}: Value of  $Z_r$  (resonant impedance).

{numeric 2}: Value of  $f_r$  (resonant frequency).

{numeric 3}: Value of  $Z_a$  (anti-resonant impedance).

{numeric 4}: Value of  $f_a$  (anti-resonant frequency).

This command searches for points of phase  $0^\circ$  within the analysis range from the left edge, and defines the 1st detected point as the resonant point and the 2nd detected point as the anti-resonant point. Even if 3 or more phase  $0^\circ$  points are detected, only the first 2 points are used. If only 1 phase  $0^\circ$  point is detected, 0 is read out for both  $Z_a$  and  $f_a$ . If no phase  $0^\circ$  point is detected, 0 is read out for all the parameters.

Figure 16-5

**Analyzed parameters**

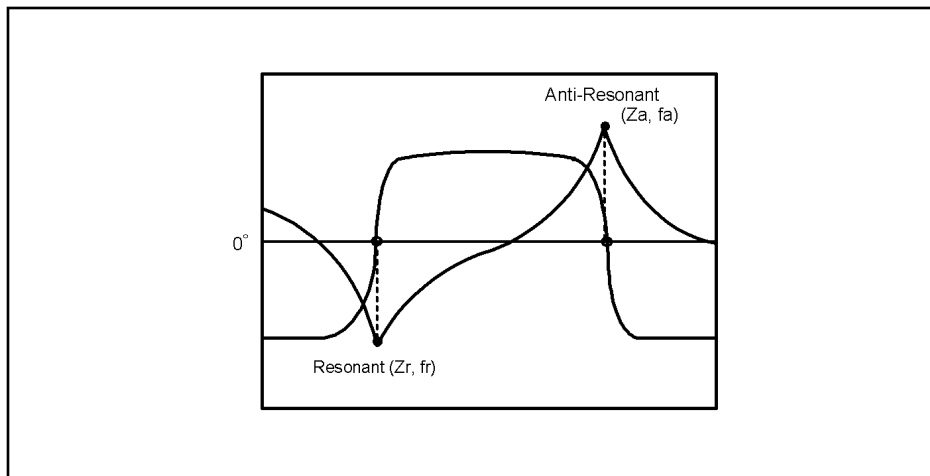

4294ape002

**Corresponding key**

No front panel key is available to execute this function.



## OUTPRESR?

<b>Syntax</b>	OUTPRESR?
<b>Description</b>	If the sweep parameter is frequency and the measurement parameter is $ Z -\theta$ , within the waveform analysis range specified with the “ANARANG” command on page 259, analyzes the resonant point and ripple, and reads out the result. If the sweep parameter is not frequency or if the measurement parameter is not $ Z -\theta$ , executing this command causes an error and all readouts are 0. (Query only)
<b>Query response</b>	<p>{numeric 1},{numeric 2},{numeric 3},{numeric 4},{numeric 5},{numeric 6},{numeric 7}&lt;newline&gt;&lt;^END&gt;</p> <p>The readouts are as follows:</p> <p>{numeric 1}: Value of <math>Z_r</math> (resonant impedance).</p> <p>{numeric 2}: Value of <math>f_r</math> (resonant frequency).</p> <p>{numeric 3}: Value of <math>Z_a</math> (anti-resonant impedance).</p> <p>{numeric 4}: Value of <math>f_a</math> (anti-resonant frequency).</p> <p>{numeric 5}: Rpl<sub>1</sub> (the maximum value of the left-side ripple (the sweep parameter difference between the peak and the left adjacent negative peak) within the range to the left of the resonant point within the waveform analysis range).</p> <p>{numeric 6}: Value of Rpl<sub>2</sub> (the maximum value of the right ripple (the sweep parameter difference between the peak and the right adjacent negative peak) within the range between the resonant point and the anti-resonant point within the waveform analysis range).</p> <p>{numeric 7}: Rpl<sub>3</sub> (the maximum value of the left-side ripple within the range to the right of the resonant point within the waveform analysis range).</p> <p>This command searches for phase 0° points within the analysis range from the left edge, and defines the 1st detected point as the resonant point and the 2nd detected point as the anti-resonant point. Even if 3 or more phase 0° points are detected, only the first 2 points are used. If only 1 phase 0° point is detected, 0 is read out for parameters other than <math>Z_r</math>, <math>f_r</math>, and Rpl<sub>1</sub>. If no phase 0° point is detected, 0 is read out for all the parameters.</p> <p>The peak and negative peak used at the execution of this command satisfies the condition set with the “THRR” command on page 439. They are not related to the peak definition in the marker search function.</p>
<b>Corresponding key</b>	No front panel key is available to execute this function.

Figure 16-6

Analyzed parameters

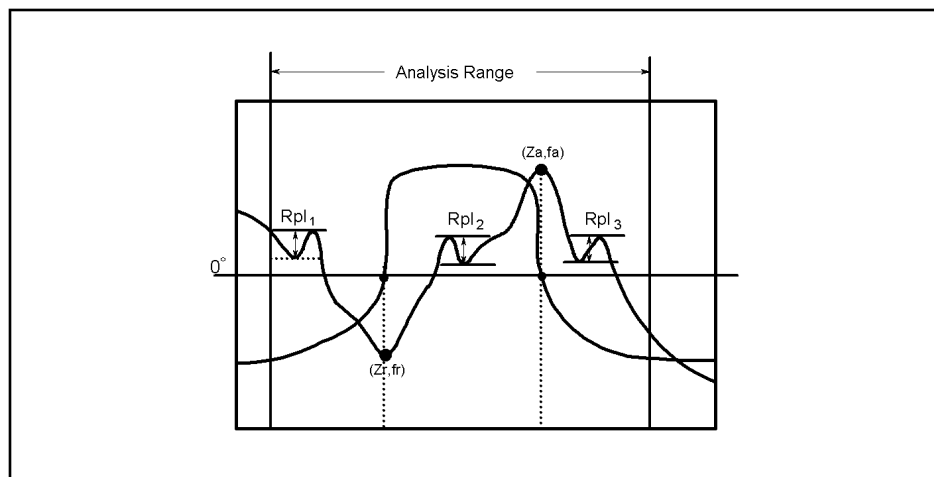

4294ape003

### OUTPSMKR{1-7}?

**Syntax**

OUTPSMKR{1|2|3|4|5|6|7}?

**Description**

For the active trace (set with the “TRAC” command on page 444), reads out the measurement parameter value and sweep parameter value at the sub marker (marker number 1 to 7) position. If the sub marker is off, executing this command causes an error and the readouts are invalid. (Query only)

**Query response**

{numeric 1}, {numeric 2}, {numeric 3} <newline><<^END>

Readouts are as follows:

{numeric 1}: Readout of the measurement parameter value at the sub marker position. If the measurement parameter is a scalar value (for other than COMPLEX Z-Y), the measurement parameter value is read out. If the measurement parameter is a vector value (for COMPLEX Z-Y), the readout is as follows.

- If the polar chart format is selected, the amplitude is read out.
- If the complex plane format is selected, resistance (for trace A) or conductance (for trace B) is read out.

{numeric 2}: Subsidiary readout of the measurement parameter value at the sub marker position. If the measurement parameter is a scalar value (for other than COMPLEX Z-Y), 0 is always read out. If the measurement parameter is a vector value (for COMPLEX Z-Y), the readout is as follows:

- If the polar chart format is selected, the phase is read out.
- If the complex plane format is selected, reactance (for trace A) or susceptance (for trace B) is read out.

{numeric 3}: Sweep parameter value at the sub marker position.

**Corresponding key**

No front panel key is available to execute this function.

### OUTPSWPRM?

- Syntax** OUTPSWPRM?
- Description** Reads out the sweep parameter values of all measurement points. (Query only)
- Query response** {numeric 1},{numeric 2},...,{numeric NOP}<newline><^END>  
 Where, NOP is the number of points.
- Corresponding key** No front panel key is available to execute this function.

### OUTPSWPRMP?

- Syntax** OUTPSWPRMP? <numeric 1>
- Description** Reads out the sweep parameter value of the specified measurement point. (Query only)
- Parameters**

	<numeric 1>
Description	Number of the measurement point you want to read out (the number assigned in order from the left edge assuming that the number of the leftmost measurement point is 1)
Range	1 to the number of points
Resolution	1

If the specified parameter is out of the allowable setting range, the minimum value (if the lower limit of the range is not reached) or the maximum value (if the upper limit of the range is exceeded) is set.

- Query response** {numeric 2}<newline><^END>

	{numeric 2}
Description	Read-out sweep parameter value

- Corresponding key** No front panel key is available to execute this function.

### OUTPVAC?

- Syntax** OUTPVAC?
- Description** When the oscillator level monitor function is set to on (set to ON with “OMON” command on page 354), reads out the oscillator voltage level monitor values of all measurement points. (Query only)
- Query response** {numeric 1},{numeric 2},...,{numeric NOP}<newline><^END>  
 Where, NOP is the number of points.  
 If the oscillator level monitor function is set to off, the readouts are invalid.
- Corresponding key** No front panel key is available to execute this function.

**OUTPVACP?**

**Syntax**                   OUTPVACP? <numeric 1>

**Description**            When the oscillator level monitor function is set to on (set to ON with “OMON” command on page 354), reads out the oscillator voltage level monitor value of the specified measurement point. (Query only)

**Parameters**

	<b>&lt;numeric 1&gt;</b>
Description	Number of the measurement point you want to read out (the number assigned in order from the left edge assuming that the number of the leftmost measurement point is 1)
Range	1 to the number of points
Resolution	1

If the specified parameter is out of the allowable setting range, the minimum value (if the lower limit of the range is not reached) or the maximum value (if the upper limit of the range is exceeded) is set.

**Query response**        {numeric 2}<newline><^END>

	<b>{numeric 2}</b>
Description	Voltage monitor value of the oscillator level

If the oscillator level monitor function is set to off, the readout is invalid.

**Corresponding key**     No front panel key is available to execute this function.

**PARS**

**Syntax**                   PARS {ON|OFF|1|0}  
 PARS?

**Description**            For the marker search function for the active trace (set with the “TRAC” command on page 444), determines whether to perform partial search.

**Parameters**

	<b>Description</b>
ON or 1	Enables the partial search.
OFF or 0 (initial value)	Disables the partial search.

**Query response**        {1|0}<newline><^END>

**Corresponding key**     [Search] - SEARCH RANGE MENU - PART SRCH on OFF

## PAVER

- Syntax** PAVER {ON|OFF|1|0}  
PAVER?
- Description** Enables/disables the point averaging function.
- Parameters**

	Description
ON or 1	Enables the point averaging function.
OFF or 0 (initial value)	Disables the point averaging function.

- Query response** {1|0}<newline><^END>
- Corresponding key** [Bw/Avg] - POINT AVG on OFF

## PAVERFACT

- Syntax** PAVERFACT <numeric>  
PAVERFACT?
- Description** Sets the point averaging count when using the point averaging function. To set the point averaging count of each segment when creating the list sweep table, also use this command.
- Parameters**

	<numeric>
Description	Point averaging count
Range	1 to 256
Initial value	4 (Note that, if you use this command to create a segment, the initial value for segment 1 is 1, and the initial value of an additional segment is the set value of the previous segment.)
Resolution	1

If the specified parameter is out of the allowable setting range, the minimum value (if the lower limit of the range is not reached) or the maximum value (if the upper limit of the range is exceeded) is set.

- Query response** {numeric}<newline><^END>
- Corresponding key** [Bw/Avg] - POINT AVG FACTOR

**PDEL**

**Syntax** PDEL <numeric>[S]  
PDEL?

**Description** Sets the delay time for each measurement point.

**Parameters**

	<b>&lt;numeric&gt;</b>
Description	Delay time for each measurement point
Range	0 to 30
Initial value	0
Unit	s (second)
Resolution	0.001

If the specified parameter is out of the allowable setting range, the minimum value (if the lower limit of the range is not reached) or the maximum value (if the upper limit of the range is exceeded) is set.

**Query response** {numeric}<newline><^END>

**Corresponding key** [Sweep] - TIME - POINT DELAY

**PEAK?**

**Syntax** PEAK?

**Description** Within the waveform analysis range set with the “ANARANG” command on page 259, searches for the maximum peak and reads out the measurement parameter value and the sweep parameter value of the peak. If there are several maximum peaks, reads out the value of the leftmost peak within the analysis range. If no peak exists, 0 is read out.

The peak searched for at the execution of this command satisfies the condition set with the “THRR” command on page 439. It is not related to the peak definition in the marker search function. (Query only)

**Query response** {numeric 1},{numeric 2}<newline><^END>

Readouts are as follows:

{numeric 1}: Measurement parameter value of the maximum peak.

{numeric 2}: Sweep parameter value of the maximum peak.

**Corresponding key** No front panel key is available to execute this function.

## PEAKCENT

**Syntax** PEAKCENT

**Description** For the active trace (set with the “TRAC” command on page 444), searches for a peak using the marker and changes the sweep center value setting to the marker sweep parameter value (in other words, the sweep parameter value of the detected peak). If the marker function is off, executing this command causes an error and the command is ignored. (No query)

**Corresponding key** [Marker→] - more 1/2 - PEAK → CENTER

## PHAU

**Syntax** PHAU {DEG|RAD}  
 PHAU?

**Description** For the active trace (set with the “TRAC” command on page 444), sets the display unit in the phase display format. The scale parameters in the selected unit are automatically set so that traces do not exceed the display range on the screen.

**Parameters**

	Description
DEG (initial value)	Specifies degree (°) as the display unit.
RAD	Specifies radian as the display unit.

**Query response** {DEG|RAD}<newline><^END>

**Corresponding key** [Format] - PHASE UNIT [ ]

## PKDLTX

**Syntax** PKDLTX <numeric>[HZ|MHZ|V|A]

PKDLTX?

**Description** For the active trace (set with the “TRAC” command on page 444), sets the  $\Delta X$  value (refer to Figure 7-1 on page 97) parameter to define the peak searched for in the marker search function.

### Parameters

		<numeric>
Description		$\Delta X$ value
When the sweep parameter is frequency	Range	0 to 110E6
	Initial value	500E3
	Unit	Hz
When the sweep parameter is OSC level (voltage)	Range	0 to 1
	Initial value	5E-3
	Unit	V (volt)
When the sweep parameter OSC level (current)	Range	0 to 20E-3
	Initial value	100E-6
	Unit	A (ampere)
When the sweep parameter is dc bias level (voltage)	Range	0 to 80
	Initial value	0.4
	Unit	V (volt)
When the sweep parameter is dc bias level (current)	Range	0 to 200E-3
	Initial value	1E-3
	Unit	A (ampere)

If the specified parameter is out of the allowable setting range, the minimum value (if the lower limit of the range is not reached) or the maximum value (if the upper limit of the range is exceeded) is set.

**Query response** {numeric}<newline><^END>

**Corresponding key** [Search] - PEAK - PEAK DEF MENU - PEAK DEF:  $\Delta X$



## PKDLTY

**Syntax** PKDLTY <numeric>[OHM|DEG|RAD|SIE|H|F|PCT]  
 PKDLTY?

**Description** For the active trace (set with the “TRAC” command on page 444), sets the  $\Delta Y$  value (refer to Figure 7-1 on page 97) parameter to define the peak searched for in the marker search function.

**Parameters**

	<numeric>
Description	$\Delta Y$ value
Range	0 to 100E6
Initial value	1
Unit	Varies depending on the measurement parameter (refer to the explanation of unit in “SCAL” on page 410).

If the specified parameter is out of the allowable setting range, the minimum value (if the lower limit of the range is not reached) or the maximum value (if the upper limit of the range is exceeded) is set.

**Query response** {numeric}<newline><^END>

**Corresponding key** [Search] - PEAK - PEAK DEF MENU - PEAK DEF:  $\Delta Y$

## PKPOL

**Syntax** PKPOL {POS|NEG}  
 PKPOL?

**Description** For the active trace (set with the “TRAC” command on page 444), sets the polarity of the peak searched for in the marker search function.

**Parameters**

	Description
POS (initial value)	Specifies positive peaks.
NEG	Specifies negative peaks.

**Query response** {POS|NEG}<newline><^END>

**Corresponding key** [Search] - PEAK - PEAK DEF MENU - PEAK PLRTY [ ]

16. GPIB  
 Command Reference  
 (O - R)

**POIN**

**POIN**

**Syntax** POIN <numeric>

POIN?

**Description** Sets the number of points measured at each sweep. To set the number-of-points setting of each segment when creating the list sweep table, also use this command.

**Parameters**

	<b>&lt;numeric&gt;</b>
Description	Number of points
Range	2 to 801 (Note on the number-of-points setting of a segment. The upper limit is the smaller value: value obtained by subtracting the sum of the numbers of points of already set segments from 801 or 201.)
Initial value	201 (Note on the number-of-points setting of a segment. If the maximum number of settable points is less than 201, the maximum number of settable points.)
Resolution	1

If the specified parameter is out of the allowable setting range, the minimum value (if the lower limit of the range is not reached) or the maximum value (if the upper limit of the range is exceeded) is set.

**Query response** {numeric}<newline><^END>

**Corresponding key** [Sweep] - NUMBER OF POINTS

**PORE**

**Syntax** PORE {ON|OFF|1|0}

PORE?

**Description** Toggles on and off the port extension compensation function.

**Parameters**

	<b>Description</b>
ON or 1	Turns on the port extension compensation function.
OFF or 0 (initial value)	Turns off the port extension compensation function.

**Query response** {1|0}<newline><^END>

**Corresponding key** [CAL] - PORT EXTENSION - EXTENSION on OFF

## PORTL

**Syntax** PORTL <numeric>[M]  
 PORTL?

**Description** Sets the port extension compensation amount in electrical length.

**Parameters**

	<numeric>
Description	Port extension compensation amount
Range	-10×2.998E8 to 10×2.998E8
Initial value	0
Unit	m (meter)
Resolution	1E-6

If the specified parameter is out of the allowable setting range, the minimum value (if the lower limit of the range is not reached) or the maximum value (if the upper limit of the range is exceeded) is set.

**Query response** {numeric}<newline><^END>

**Corresponding key** [CAL] - PORT EXTENSION - VALUE (RENGTH)

## PORTZ

**Syntax** PORTZ <numeric>[S]  
 PORTZ?

**Description** Sets the port extension compensation amount in time.

**Parameters**

	<numeric>
Description	Port extension compensation amount
Range	-10 to 10
Initial value	0
Unit	s (second)
Resolution	1E-12

If the specified parameter is out of the allowable setting range, the minimum value (if the lower limit of the range is not reached) or the maximum value (if the upper limit of the range is exceeded) is set.

**Query response** {numeric}<newline><^END>

**Corresponding key** [CAL] - PORT EXTENSION - VALUE (TIME)

**POSL**

**Syntax** POSL  
 POSL?

**Description** Sets the input/output signals of the 24-bit I/O port (data and test PASS/FAIL output) to positive logic. To set to negative logic, use the “NEGL” command on page 351.

**Query response** {1|0}<newline><^END>

	Description
1	Positive logic is specified.
0	Positive logic is not specified. In other words, negative logic (preset state) is specified.

**Corresponding key** No front panel key is available to execute this function.

**POWE**

**Syntax** POWE <numeric>[V|A]  
 POWE?

**Description** Sets the oscillator (OSC) power level. To set the oscillator power level of each segment when creating the list sweep table, also use this command. To select voltage or current to set the level, use the “POWMOD” command on page 393.

**Parameters**

	<numeric>
Description	Oscillator power level
Range	For voltage setting: 5E-3 to 1 For current setting: 200E-6 to 20E-3
Initial value	For voltage setting: 0.5 For current setting: 200E-6
Unit	For voltage setting: V (volt) For current setting: A (ampere)
Resolution	For voltage setting: 1E-3 For current setting: 10E-6

Note that, if you use this command to create a segment, the initial value when creating segment 1 is the current oscillator power level value and the initial value when creating an additional segment is the oscillator power level value of the previous segment.

If the specified parameter is out of the allowable setting range, the minimum value (if the lower limit of the range is not reached) or the maximum value (if the upper limit of the range is exceeded) is set.

**Query response** {numeric}<newline><^END>

**Corresponding key** [Source] - LEVEL

## POWMOD

**Syntax** POWMOD {VOLT|CURR}  
 POWMOD?

**Description** Selects voltage or current to set the oscillator (OSC) power level. To set the oscillator power level setting method of each segment when creating the list sweep table, use this command.

**Parameters**

	Description
VOLT (initial value)	Specifies the voltage setting.
CURR	Specifies the current setting.

Note that, if you use this command to create a segment, the initial value when creating segment 1 is the current setting method selection value and the initial value when creating an additional segment is the setting method selection value of the previous segment.

**Query response** {VOLT|CURR}<newline><^END>

**Corresponding key** [Source] - OSC UNIT [ ]

### PREP

**Syntax** PREP

**Description** When the measurement results are listed as a result of the execution of the “LISV” command on page 330, displays the previous page of the list. To display the next page, execute the “NEXP” command on page 352.(No query)

**Corresponding key** [Copy] - SELECT CONTENTS - LIST VALUE - PREV PAGE

### PRES

**Syntax** PRES

**Description** Resets to the preset state. The preset state is almost the same as that of the reset using the “\*RST” command on page 252, though there are some differences shown bellow. (No query)

- The sweep mode is set to CONT.
- The HP Instrument BASIC is not reset.

**Corresponding key** [Preset]

16. GPIB  
 Command Reference  
 (O - R)

**PRIC**

**Syntax** PRIC {STAN|FIXE|VARI}  
 PRIC?

**Description** Sets the print color for printout.

**Parameters**

	Description
STAN (initial value)	Black and white output
FIXE	Color output (clean colors when printed on white paper)
VARI	Color output (colors close to those on the display screen)

**Query response** {STAN|FIXE|VARI}<newline><^END>

**Corresponding key** [Copy] - SETUP - {B&W | FIXED COLOR | IMAGE COLOR}

**PRINALL**

**Syntax** PRINALL

**Description** Outputs as-is image displayed on the LCD screen to a printer. Note that, softkey label output is disabled (specified to OFF with the “PRSOFT” command on page 394), the softkey labels at the left of the screen are not outputted. (No query)

**Corresponding key** [Copy] - START

**PRSOFT**

**Syntax** PRSOFT {ON|OFF|1|0}  
 PRSOFT?

**Description** When outputting the LCD screen to a printer using the “PRINALL” command on page 394, enables/disables the output of the description part (softkey label) of each softkey displayed at the right of the screen.

**Parameters**

	Description
ON or 1	Enables the softkey label output.
OFF or 0 (initial value)	Disables the softkey label output.

**Query response** {1|0}<newline><^END>

**Corresponding key** [Copy] - SETUP - more 1/2 - SOFTKEY on OFF

## PURG

**Syntax** PURG <string>

**Description** Deletes the specified file on a built-in mass storage of the 4294A specified with the “STOD” command on page 432. When specifying a file, use a file name including its extension (refer to Table 8-1 on page 113). If the specified file does not exist, an error occurs. (No query)

**Parameters**

	<b>&lt;string&gt;</b>
Description	File name (including the extension) you want to delete
Range	12 characters or less (including the extension)

If the specified file name has characters that exceed the maximum length, only the string of up to the maximum length is valid and the remaining characters are ignored.

**Corresponding key** **[Save] - FILE UTILITIES - PURGE FILE >**

## RECD

**Syntax** RECD <string>

**Description** Recalls an instrument state or measured data from the specified file on a built-in mass storage of the 4294A specified with the “STOD” command on page 432. When specifying a file, use a file name including its extension (refer to Table 8-1 on page 113). If the specified file does not exist, an error occurs and the command is ignored. (No query)

**Parameters**

	<b>&lt;string&gt;</b>
Description	File name (including the extension) you want to recall
Range	12 characters or less (including the extension)

If the specified file name has characters that exceed the maximum length, only the string of up to the maximum length is valid and the remaining characters are ignored.

**Corresponding key** **[Recall]**

## REFP

**Syntax** REFP <numeric>  
REFP?

**Description** Specifies the position of the reference line in the linear Y axis format. To specify the position, use the grid line number, which is given in the increasing order from the bottom assuming that the bottom grid line is 0.

### Parameters

	<numeric>
Description	Position of the reference line (grid line number)
Range	0 to 10
Initial value	5 (0, if the measurement parameter is  Z  and  Y .)
Resolution	0.01

If the specified parameter is out of the allowable setting range, the minimum value (if the lower limit of the range is not reached) or the maximum value (if the upper limit of the range is exceeded) is set.

**Query response** {numeric}<newline><^END>

**Corresponding key** [Scale Ref] - REFERENCE POSITION



## REFV

**Syntax** REFV <numeric>[OHM|DEG|RAD|SIE|H|F|PCT]  
REFV?

**Description** Sets the value indicating the reference line in the linear Y axis format, or the full scale value in the polar chart format. To set the value indicating the reference line in the complex plane format, use the “REFX” command on page 398 and “REFY” command on page 398.

### Parameters

	<numeric>
Description	Value indicated by the reference line or full scale
Range	For the linear Y axis format: Varies depending on the measurement parameter as follows: For  Z , R, X: -1E12 to 1E12 For other than  Z , R, X: -1E9 to 1E9 For polar chart format: 10E-15 to 1E9
Initial value	For the linear Y axis format: Varies depending on the measurement parameter as follows: For  Z , R, X, Rs, Rp: 500E3 For $\theta$ : 0 For  Y , G, B, D: 500E-3 For Cs, Cp: 500E-6 For Ls, Lp: 5 For Q: 500 For polar chart format: 1
Unit	Varies depending on the measurement parameter (refer to the explanation of unit in “SCAL” on page 410).
Resolution	1E-15 *1

\*1. This is the minimum value (when the set value is small). The resolution becomes larger as the set value becomes larger.

If the specified parameter is out of the allowable setting range, the minimum value (if the lower limit of the range is not reached) or the maximum value (if the upper limit of the range is exceeded) is set.

**Query response** {numeric}<newline><^END>

**Corresponding key** [Scale Ref] - REFERENCE VALUE

**REFX**

**Syntax** REFX <numeric>[OHM|SIE]  
 REFX?

**Description** Sets the X-axis reference value (center value) in the complex plane format.

**Parameters**

	<numeric>
Description	X-axis reference value
Range	-1E9 to 1E9
Initial value	0
Unit	For trace A: Ω (ohm) For trace B: S (siemens)
Resolution	1E-15 *1

\*1.This is the minimum value (when the set value is small). The resolution becomes larger as the set value becomes larger.

If the specified parameter is out of the allowable setting range, the minimum value (if the lower limit of the range is not reached) or the maximum value (if the upper limit of the range is exceeded) is set.

**Query response** {numeric}<newline><^END>

**Corresponding key** [Scale Ref] - REFERENCE X VALUE

**REFY**

**Syntax** REFY <numeric>[OHM|SIE]  
 REFY?

**Description** Sets the Y-axis reference value (center value) in the complex plane format.

**Parameters**

	<numeric>
Description	Y-axis reference value
Range	-1E9 to 1E9
Initial value	0
Unit	For trace A: Ω(ohm) For trace B: S (siemens)
Resolution	1E-15 *1

\*1.This is the minimum value (when the set value is small). The resolution becomes larger as the set value becomes larger.

If the specified parameter is out of the allowable setting range, the minimum value (if the lower limit of the range is not reached) or the maximum value (if the upper limit of the range is exceeded) is set.

**Query response** {numeric}<newline><^END>

**Corresponding key** [Scale Ref] - REFERENCE Y VALUE

## RESAVD

**Syntax** RESAVD <string>

**Description** Updates the specified file on the built-in mass storage of the 4294A specified with the “STOD” command on page 432. When specifying a file, use a file name including its extension (refer to Table 8-1 on page 113). If the specified file does not exist, an error occurs and the command is ignored. (No query)

**Parameters**

	<b>&lt;string&gt;</b>
Description	File name (including the extension) you want to update
Range	12 characters or less (including the extension)

If the specified file name has characters that exceed the maximum length, only the string of up to the maximum length is valid and the remaining characters are ignored.

**Corresponding key** [Save] - RE-SAVE FILE >

## RESD

**Syntax** RESD

**Description** Changes the measured value list display screen to the normal measurement screen. To return to the list display screen, execute the “LISV” command on page 330. (No query)

**Corresponding key** [Copy] - SELECT CONTENTS - LIST VALUE - RESTORE DISPLAY >

## RPLHEI?

<b>Syntax</b>	RPLHEI?
<b>Description</b>	<p>Within the waveform analysis range specified with the “ANARANG” command on page 259, calculates ripples (measurement parameter value difference between the peak and its right and left adjacent negative peaks), and reads out the maximum value. If the value cannot be obtained because no peak or negative peak is detected, 0 is read out.</p> <p>The peak and negative peak used at the execution of this command satisfies the condition set with the “THRR” command on page 439. It is not related to the peak definition in the marker search function. (Query only)</p>
<b>Query response</b>	{numeric}<newline><^END>
<b>Corresponding key</b>	No front panel key is available to execute this function.

## RPLLHEI?

<b>Syntax</b>	RPLLHEI?
<b>Description</b>	<p>Within the waveform analysis range specified with the “ANARANG” command on page 259, calculates the left-side ripple (measurement parameter value difference between the peak and its left adjacent negative peak), and reads out the maximum value. If the value cannot be obtained because no peak or negative peak is detected, 0 is read out.</p> <p>The peak and negative peak used at the execution of this command satisfies the condition set with the “THRR” command on page 439. It is not related to the peak definition in the marker search function. (Query only)</p>
<b>Query response</b>	{numeric}<newline><^END>
<b>Corresponding key</b>	No front panel key is available to execute this function.

## RPLPP?

<b>Syntax</b>	RPLPP?
<b>Description</b>	<p>Within the waveform analysis range specified with the “ANARANG” command on page 259, reads out the difference between the maximum peak measurement parameter value and the minimum negative peak measurement parameter value. If the value cannot be obtained because no peak or negative peak is detected, 0 is read out.</p> <p>The peak searched for at the execution of this command satisfies the condition set with the “THRR” command on page 439. It is not related to the peak definition in the marker search function. (Query only)</p>
<b>Query response</b>	{numeric}<newline><^END>
<b>Corresponding key</b>	No front panel key is available to execute this function.

## RPLPPS?

<b>Syntax</b>	RPLPPS?
<b>Description</b>	<p>Within the waveform analysis range specified with the “ANARANG” command on page 259, reads out the difference between the maximum peak measurement parameter value and the minimum negative peak measurement parameter value and the sweep parameter value of the peaks (if there are several maximum peaks or minimum negative peaks, the value of the leftmost peak within the analysis range). If the value cannot be obtained because no peak or negative peak is detected, 0 is read out.</p> <p>The peak and negative peak used at the execution of this command satisfies the condition set with the “THRR” command on page 439. It is not related to the peak definition in the marker search function. (Query only)</p>
<b>Query response</b>	<p>{numeric 1},{numeric 2},{numeric 3}&lt;newline&gt;&lt;^END&gt;</p> <p>Readouts are as follows:</p> <p>{numeric 1}:       Difference between the maximum peak measurement parameter value and the minimum negative peak measurement parameter value.</p> <p>{numeric 2}:       Sweep parameter value of the maximum peak.</p> <p>{numeric 3}:       Sweep parameter value of the minimum negative peak.</p>
<b>Corresponding key</b>	No front panel key is available to execute this function.

## RPLRHEI?

<b>Syntax</b>	RPLRHEI?
<b>Description</b>	<p>Within the waveform analysis range specified with the “ANARANG” command on page 259, calculates the right ripple (measurement parameter value difference between the peak and its right adjacent negative peak), and reads out the maximum value. If the value cannot be obtained because no peak or negative peak is detected, 0 is read out.</p> <p>The peak and negative peak used at the execution of this command satisfies the condition set with the “THRR” command on page 439. It is not related to the peak definition in the marker search function. (Query only)</p>
<b>Query response</b>	{numeric}<newline><^END>
<b>Corresponding key</b>	No front panel key is available to execute this function.

## RSCO

<b>Syntax</b>	RSCO
<b>Description</b>	Returns the tint (set with the “TINT” command on page 441), brightness (set with the “CBRI” command on page 268), and chroma (set with the “COLOR” command on page 273) of the display color of the item selected with the “COLO” command on page 272 to the factory states. (No query)
<b>Corresponding key</b>	[Display] - more 1/2 - MODIFY COLOR - MODIFY ITEM COLOR - MODIFY COLOR - RESET COLOR

## **SADD**

### **Syntax**

SADD [<numeric>]

### **Description**

In creation/edit of the list sweep table, adds a new segment, change the edit target segment to the added segment, and starts edit. The position where a segment is added is as follows:

- If a segment is specified:  
Added in the line below the specified segment.
- If no segment is specified:  
Added in the line below the segment specified as the edit target segment (set with the “SEGM” command on page 422).

The number of the added segment is a value of the specified segment number (if no segment is specified, the edit target segment number before the execution of the command) plus 1, and the number of each following segment also increases by 1.

After the completion of the parameter setting of the segment, execute the “SDON” command on page 413 to finish the edit work. After executing this command and the “SEDI” command on page 421 (to start segment edit), executing this command, without executing the “SDON” command, causes an error and the command is ignored.

If the total number of points in segments is 800 or 801, executing this command causes an error, and, without adding a segment, the edit of the specified segment (if no segment is specified, the segment set as the edit target) is started.

If the creation/edit of the previous segment has not been started, executing this command automatically starts table creation/edit and then adds a segment. (No query)

### **Parameters**

	<b>&lt;numeric&gt;</b>
Description	Segment number immediately before the addition and insertion location
Range	1 to the number of segments in the list sweep table
Resolution	1

If the specified parameter is out of the allowable setting range, the minimum value (if the lower limit of the range is not reached) or the maximum value (if the upper limit of the range is exceeded) is set.

### **Corresponding key**

[Sweep] - EDIT LIST - ADD ➤

## SAVCAL

**Syntax** SAVCAL {ON|OFF|1|0}  
SAVCAL?

**Description** When saving the internal data array (refer to “Internal data arrays” on page 81) in a file with the “SAVDASC” command on page 403 and “SAVDDAT” command on page 404, enables/disables the save of the calibration data array and compensation data array. If user calibration data has not been measured or inputted using the command, the save file does not contain values in the calibration data array. This is also applicable to the compensation data array.

**Parameters**

	Description
ON or 1	Enables the save of the calibration data array and compensation data array.
OFF or 0 (initial value)	Disables the save of the calibration data array and compensation data array.

**Query response** {1|0}<newline><^END>

**Corresponding key** [Save] - DATA - SELECT CONTENTS - CAL on OFF

## SAVDASC

**Syntax** SAVDASC <string>

**Description** Saves the internal data arrays (refer to “Internal data arrays” on page 81) specified to be saved with the “SAVCAL”(403page), “SAVDAT”(404page), “SAVDTRC”(407page), “SAVMEM”(407page) and “SAVMTRC”(408page) commands in the ASCII format into the specified file. The number of saved points is the current number of sweep points. When specifying a file, you can use a file name including its extension (refer to Table 8-1 on page 113) or a file name whose extension is omitted. If the extension is not specified, the file name is the specified file name with the “.TXT” extension added. (No query)

**Parameters**

	<string>
Description	Save file name
Range	When the extension is not specified: 8 characters or less When the extension is specified: 12 characters or less

If the specified file name has characters that exceed the maximum length, only the string of up to the maximum length is valid and the remaining characters are ignored.

**Corresponding key** [Save] - DATA - ASCII ►

**SAVDAT**

**SAVDAT**

**Syntax** SAVDAT {ON|OFF|1|0}

SAVDAT?

**Description** When saving the internal data array (refer to “Internal data arrays” on page 81) into a file with the “SAVDASC” command on page 403 and “SAVDDAT” command on page 404 commands, enables/disables the save of the data array.

**Parameters**

	Description
ON or 1	Enables the save of the data array.
OFF or 0 (initial value)	Disables the save of the data array.

**Query response** {1|0}<newline><^END>

**Corresponding key** [Save] - DATA - SELECT CONTENTS - DATA on OFF

**SAVDDAT**

**Syntax** SAVDDAT <string>

**Description** Saves the internal data arrays (refer to “Internal data arrays” on page 81) specified to be saved with the “SAVCAL”(403page), “SAVDAT”(404page), “SAVDTRC”(407page), “SAVMEM”(407page) and “SAVMTRC”(408page) commands in the binary format into the specified file. The number of saved points is the current number of sweep points. When specifying a file, you can use a file name including its extension (refer to Table 8-1 on page 113) or a file name whose extension is omitted. If the extension is not specified, the file name is the specified file name with the “.DAT” extension added. (No query)

**Parameters**

	<string>
Description	Save file name
Range	When the extension is not specified: 8 characters or less When the extension is specified: 12 characters or less

If the specified file name has characters that exceed the maximum length, only the string of up to the maximum length is valid and the remaining characters are ignored.

**Corresponding key** [Save] - DATA - BINARY ►



## SAVDS1P

**Syntax** SAVDS1P <string>

**Description** Converts the data array into the touchstone format and saves it into a specified file. You can use a file name with or without the extension (refer to Table 8-1, “Filename extension,”) to specify a file. When you omit the extension, the extension ".S1P" is added to the specified file name. (No query)

**Parameters**

	<b>&lt;string&gt;</b>
Description	A file name you want to save.
Range	When you omit the extension: 8 characters or less When you specify the extension: 12 characters or less

If the specified file name exceeds the maximum number of characters, characters until the maximum is reached are valid and remaining characters are ignored.

**Equivalent key** [Save] - TOUCHSTONE ►

## SAVDSTA

**Syntax** SAVDSTA <string>

**Description** Saves the instrument setting state, calibration data array, compensation data array, and memory array (refer to “Internal data arrays” on page 81) into the specified file. Regardless of the settings with the “SAVCAL”(403page), “SAVDAT”(404page), “SAVDTRC”(407page), “SAVMEM”(407page) and “SAVMTRC”(408page) commands, the arrays are saved. When specifying a file, you can use a file name including its extension (refer to Table 8-1 on page 113) or a file name whose extension is omitted. If the extension is not specified, the file name is the specified file name with the “.STA” extension added. (No query)

### Parameters

	<string>
Description	Save file name
Range	When the extension is not specified: 8 characters or less When the extension is specified: 12 characters or less

If the specified file name has characters that exceed the maximum length, only the string of up to the maximum length is valid and the remaining characters are ignored.

**Corresponding key** [Save] - STATE >

## SAVDTIF

**Syntax** SAVDTIF <string>

**Description** Saves image on the LCD screen into the specified file in the TIF format. When specifying a file, you can use a file name including its extension (refer to Table 8-1 on page 113) or a file name whose extension is omitted. If the extension is not specified, the file name is the specified file name with the “.TIF” extension added.(No query)

### Parameters

	<string>
Description	Save file name
Range	When the extension is not specified: 8 characters or less When the extension is specified: 12 characters or less

If the specified file name has characters that exceed the maximum length, only the string of up to the maximum length is valid and the remaining characters are ignored.

**Corresponding key** [Save] - GRAPHICS >

## SAVDTRC

**Syntax** SAVDTRC {ON|OFF|1|0}  
SAVDTRC?

**Description** When saving the internal data array (refer to “Internal data arrays” on page 81) into a file using the “SAVDASC” command on page 403 and “SAVDDAT” command on page 404, enables/disables the save of the data trace array.

**Parameters**

	Description
ON or 1 (initial value)	Enables the save of the data trace array.
OFF or 0	Disables the save of the data trace array.

**Query response** {1|0}<newline><<^END>

**Corresponding key** [Save] - DATA - SELECT CONTENTS - TRACE DATA ON off

## SAVMEM

**Syntax** SAVMEM {ON|OFF|1|0}  
SAVMEM?

**Description** When saving the internal data array (refer to “Internal data arrays” on page 81) into a file using the “SAVDASC” command on page 403 and “SAVDDAT” command on page 404, enables/disables the save of the memory array.

**Parameters**

	Description
ON or 1	Enables the save of the memory array.
OFF or 0 (initial value)	Disables the save of the memory array.

**Query response** {1|0}<newline><<^END>

**Corresponding key** [Save] - DATA - SELECT CONTENTS - MEMORY on OFF

## SAVMTRC

**Syntax** SAVMTRC {ON|OFF|1|0}

SAVMTRC?

**Description** When saving the internal data array (refer to “Internal data arrays” on page 81) into a file using the “SAVDASC” command on page 403 and “SAVDDAT” command on page 404, enables/disables the save of the memory trace array.

### Parameters

	Description
ON or 1 (initial value)	Enables the save of the memory trace array.
OFF or 0	Disables the save of the memory trace array.

**Query response** {1|0}<newline><^END>

**Corresponding key** [Save] - DATA - SELECT CONTENTS - TRACE MEN ON off

## SAVPSTA

**Syntax** SAVPSTA

**Description** Saves the current instrument state and internal data arrays (refer to “Internal data arrays” on page 81) into the built-in mass storage, flash memory, as a file having the AUTOREC.STA file name. The AUTOREC.STA file is automatically recalled at power-on. Therefore, if you execute this command before power-off, the instrument state and internal data arrays before the power-off can be restored at the next power-on. (No query)

**Corresponding key** [Save] - POWER ON CONFIG >

## SCAC

**Syntax** SCAC {ON|OFF|1|0}  
SCAC?

**Description** For the active trace (set with the “TRAC” command on page 444), enables/disables the use of the same scale for the data trace and memory trace. If the scale setting differs between the data trace and the memory trace, executing this command to specify the use of the same scale unifies the scale setting to that of the scale setting target trace (set with the “SCAF” command on page 409).

If either the data trace or the memory trace is not displayed, executing this command causes an error and the command is ignored.

**Parameters**

	Description
ON or 1 (initial value)	Enables the use of the same scale.
OFF or 0	Disables the use of the same scale.

**Query response** {1|0}<newline><^END>

**Corresponding key** [Scale Ref] - more1/2 - D&M COUPLE ON off

## SCAF

**Syntax** SCAF {DATA|MEMO}  
SCAF?

**Description** For the active trace (set with the “TRAC” command on page 444), if the setting is made so that data trace and memory trace do not use the same scale (set to OFF with the “SCAC” command on page 409), selects the trace to which the scale setting is applied.

If either the data trace or the memory trace is not displayed, executing this command causes an error and the command is ignored.

**Parameters**

	Description
DATA (initial value)	Specifies the data trace to which the scale setting is applied.
MEMO	Specifies the memory trace to which the scale setting is applied.

**Query response** {DATA|MEMO}<newline><^END>

**Corresponding key** [Scale Ref] - more1/2 - SCALE FOR [ ]

SCAL

SCAL

**Syntax** SCAL <numeric>[OHM|DEG|RAD|SIE|H|F|PCT]

SCAL?

**Description** Sets the value of 1 grid tick in the Y axis (vertical axis) direction in the linear Y axis format or the value of 1 grid tick in the X axis (horizontal axis) and Y axis directions in the complex plane format.

**Parameters**

	<numeric>
Description	Value of 1 grid tick
Range	1E-15 to 100E6
Initial value	For the linear Y axis format: Varies depending on the measurement parameter as follows: For  Z , R, X, Rs, Rp: 100E3 For $\theta$ : 36 For  Y , G, B, D: 100E-3 For Cs, Cp: 100E-6 For Ls, Lp: 1 For Q: 100 For the complex plane format: 50
Unit	Varies depending on the measurement parameter as follows: For  Z , Z, R, X, Rs, Rp: $\Omega$ (ohm) For $\theta$ : $^{\circ}$ (degree) *1 For  Y , Y, G, B: S (siemens) For Cs, Cp: F (farad) For Ls, Lp: H (henry) For Q, D: No unit
Resolution	1E-15 *2

\*1.Can be changed to radian using the “PHAU” command on page 387.

\*2.This is the minimum value (when the set value is small). The resolution becomes larger as the set value becomes larger.

If the specified parameter is out of the allowable setting range, the minimum value (if the lower limit of the range is not reached) or the maximum value (if the upper limit of the range is exceeded) is set.

**Query response** {numeric}<newline><^END>

**Corresponding key** [Scale Ref] - SCALE/DIV

## SCOL

**Syntax** SCOL <numeric>  
 SCOL?

**Description** In the creation/edit of the list sweep table, specifies the trace color of each segment using pen number in the HP Instrument BASIC screen.

**Parameters**

	<numeric>
Description	Pen number
Range	1 to 6
Initial value	For the trace A: 3 For the trace B: 5
Resolution	1

If the specified parameter is out of the allowable setting range, the minimum value (if the lower limit of the range is not reached) or the maximum value (if the upper limit of the range is exceeded) is set.

**Query response** {numeric}<newline><^END>

**Corresponding key** [Sweep] - EDIT LIST - PEN

## SCRN

**Syntax** SCRN {ON|OFF|1|0}

**Description** Toggles on and off the LCD screen display. (No query)

**Parameters**

	Description
ON or 1 (initial value)	Turns on the LCD screen display.
OFF or 0	Turns off the LCD screen display.

**Corresponding key** No front panel key is available to execute this function.

## SDEL

**Syntax** SDEL [<numeric>]

**Description** In the creation/edit of the list sweep table, deletes the specified segment (if no segment is specified, the segment specified as the edit target) from the table.

The segment number of each segment after the deleted segment decreases by 1. As a result, the segment, whose number was changed to the same number as the deleted segment, is set to the edit target. Note that, if the last segment is deleted, the segment immediately before the deleted segment is set to the edit target. You can set any segment to the edit target using the “SEGM” command on page 422.

During segment edit (after the execution of the “SADD” command on page 402 or “SEDI” command on page 421 and before the execution of the “SDON” command on page 413), executing this command causes an error and the command is ignored.

If the creation/edit of the list sweep table has not been started, executing this command automatically starts table creation/edit and then deletes the segment. (No query)

---

**NOTE** Executing the “EDITDONE” command on page 300 brings the created/edited list sweep table to take effect.

---

### Parameters

	<numeric>
Description	Segment number you want to delete
Range	1 to the number of segments in the list sweep table
Resolution	1

If the specified parameter is out of the allowable setting range, the minimum value (if the lower limit of the range is not reached) or the maximum value (if the upper limit of the range is exceeded) is set.

**Corresponding key** [Sweep] - EDIT LIST - DELETE



## SDEL

**Syntax** SDEL <numeric>[S]  
SDEL?

**Description** Sets the delay time for each sweep.

**Parameters**

	<numeric>
Description	Delay time for each sweep
Range	0 to 30
Initial value	0
Unit	s (second)
Resolution	0.001

If the specified parameter is out of the allowable setting range, the minimum value (if the lower limit of the range is not reached) or the maximum value (if the upper limit of the range is exceeded) is set.

**Query response** {numeric}<newline><^END>

**Corresponding key** [Sweep] -TIME - SWEEP DELAY

**SDON**

**Syntax** SDON

**Description** In creation/edit of the list sweep table, finishes segment creation/edit. Executing this command brings the created/edited segment to take effect. (No query)

---

**NOTE** Executing the “EDITDONE” command on page 300 brings the created/edited list sweep table to take effect.

---

**Corresponding key** [Sweep] - EDIT LIST - EDIT - done

**SEAL**

**Syntax** SEAL

**Description** For the active trace (set with the “TRAC” command on page 444), moves the marker to the target (set with the “SEATARG” command on page 420) to the left of the current marker position. If no target is detected, the marker is not moved and the message saying “Not detected” is displayed (no error occurs). If the marker function is off, executing this command causes an error and the command is ignored. (No query)

**Corresponding key** [Search] - TARGET - SEARCH LEFT

**SEAM**

**Syntax** SEAM {MAX|MIN|TARG|PEAK|OFF}  
 SEAM?

**Description** For the active trace (set with the “TRAC” command on page 444), executes the specified search function. If no search target is detected, the message saying “Not detected” is displayed (no error occurs).

**Parameters**

	Description
MAX	Specifies the maximum value search.
MIN	Specifies the minimum value search.
TARG	Specifies the target search. The target closest to the current marker position is searched for.
PEAK	Specifies the peak search. The maximum peak (minimum peak if the peak has been defined as negative peak) is searched for.
OFF (initial value)	Turns off the search function.

**Query response** {MAX|MIN|TARG|PEAK|OFF}<newline><^END>

**Corresponding key** [Search] - {MAX | MIN | TRAGET ► | PEAK ►}

**SEANPK**

**Syntax** SEANPK

**Description** For the active trace (set with the “TRAC” command on page 444), moves the marker to the next smaller peak of the last detected peak. If no peak is detected, the message saying “Not detected” is displayed (no error occurs). If the marker function is off, executing this command causes an error and the command is ignored. (No query)

**Corresponding key** [Search] - PEAK - NEXT PEAK

**SEANPKL**

**Syntax** SEANPKL

**Description** For the active trace (set with the “TRAC” command on page 444), moves the marker to a peak to the left of the current marker position. If no peak is detected, the message saying “Not detected” is displayed (no error occurs). If the marker function is off, executing this command causes an error and the command is ignored. (No query)

**Corresponding key** [Search] - PEAK - NEXT PEAK LEFT

## SEANPKR

**Syntax** SEANPKR  
**Description** For the active trace (set with the “TRAC” command on page 444), moves the marker to a peak to the right of the current marker position. If no peak is detected, the message saying “Not detected” is displayed (no error occurs). If the marker function is off, executing this command causes an error and the command is ignored. (No query)

**Corresponding key** [Search] - PEAK - NEXT PEAK RIGHT

## SEAR

**Syntax** SEAR  
**Description** For the active trace (set with the “TRAC” command on page 444), moves the marker to the target (set with the “SEATARG” command on page 420) to the right of the current marker position. If no target is detected, the message saying “Not detected” is displayed (no error occurs). If the marker function is off, executing this command causes an error and the command is ignored. (No query)

**Corresponding key** [Search] - TARGET - SEARCH LIGHT

## SEARLINE

**Syntax** SEARLINE {ON|OFF|1|0}  
 SEARLINE?

**Description** For the active trace (set with the “TRAC” command on page 444), enables/disables the display of the lines indicating the search range at list sweep.

### Parameters

	Description
ON or 1	Enables the display of the lines indicating the search range.
OFF or 0 (initial value)	Disables the display of the lines indicating the search range.

**Query response** {1|0}<newline><^END>

**Corresponding key** [Search] - SEARCH RANGE MENU - RNG LINE on OFF

**SEARMAX**

**SEARMAX**

**Syntax** SEARMAX <numeric>[HZ|MHZ|V|A]

SEARMAX?

**Description** For the marker search function for the active trace (set with the “TRAC” command on page 444), if the partial search is enabled (specified to ON with the “PARS” command on page 384), sets the partial search range upper border value.

**Parameters**

		<numeric>
Description		Upper border value of the partial search range
When the sweep parameter is frequency	Range	40 to 110E6
	Initial value	110E6
	Unit	Hz
	Resolution	1E-3
When the sweep parameter is OSC level (voltage)	Range	5E-3 to 1
	Initial value	1
	Unit	V (volt)
	Resolution	1E-3
When the sweep parameter is OSC level (current)	Range	200E-6 to 20E-3
	Initial value	20E-3
	Unit	A (ampere)
	Resolution	1E-6
When the sweep parameter is dc bias level (voltage)	Range	-40 to 40
	Initial value	40
	Unit	V (volt)
	Resolution	1E-3
When the sweep parameter is dc bias level (current)	Range	-100E-3 to 100E-3
	Initial value	100E-3
	Unit	A (ampere)
	Resolution	20E-6

If the specified parameter is out of the allowable setting range, the minimum value (if the lower limit of the range is not reached) or the maximum value (if the upper limit of the range is exceeded) is set.

**Query response** {numeric}<newline><^END>

**Corresponding key** [Search] - SEARCH RANGE MENU - MAXIMUM

## SEARMAXP

**Syntax** SEARMAXP <numeric>  
SEARMAXP?

**Description** For the marker search function for the active trace (set with the “TRAC” command on page 444), if the partial search is enabled (specified to ON with the “PARS” command on page 384), sets the partial search range upper border value to the specified measurement point.

**Parameters**

	<numeric>
Description	Number of the measurement point you want to set to the upper border value (the number assigned in order from the left edge assuming that the number of the leftmost measurement point is 1)
Range	1 to the number of points
Initial value	number of points
Resolution	1

If the specified parameter is out of the allowable setting range, the minimum value (if the lower limit of the range is not reached) or the maximum value (if the upper limit of the range is exceeded) is set.

**Query response** {numeric}<newline><^END>

**Corresponding key** No front panel key is available to execute this function.

**SEARMIN**

**SEARMIN**

**Syntax** SEARMIN <numeric>[HZ|MHZ|V|A]

SEARMIN?

**Description** For the marker search function for the active trace (set with the “TRAC” command on page 444), if the partial search is enabled (specified to ON with the “PARS” command on page 384), sets the partial search range lower border value.

**Parameters**

		<numeric>
Description		Lower border value of the partial search range
When the sweep parameter is frequency	Range	40 to 110E6
	Initial value	40
	Unit	Hz
	Resolution	1E-3
When the sweep parameter is OSC level (voltage)	Range	5E-3 to 1
	Initial value	5E-3
	Unit	V (volt)
	Resolution	1E-3
When the sweep parameter is OSC level (current)	Range	200E-6 to 20E-3
	Initial value	200E-6
	Unit	A (ampere)
	Resolution	1E-6
When the sweep parameter is dc bias level (voltage)	Range	-40 to 40
	Initial value	-40
	Unit	V (volt)
	Resolution	1E-3
When the sweep parameter is dc bias level (current)	Range	-100E-3 to 100E-3
	Initial value	-100E-3
	Unit	A (ampere)
	Resolution	20E-6

If the specified parameter is out of the allowable setting range, the minimum value (if the lower limit of the range is not reached) or the maximum value (if the upper limit of the range is exceeded) is set.

**Query response** {numeric}<newline><^END>

**Corresponding key** [Search] - SEARCH RANGE MENU - MINIMUM

## SEARMINP

**Syntax** SEARMINP <numeric>  
SEARMINP?

**Description** For the marker search function for the active trace (set with the “TRAC” command on page 444), if the partial search is enabled (specified to ON with the “PARS” command on page 384), sets the partial search range lower border value to the specified measurement point.

**Parameters**

	<numeric>
Description	Number of the measurement point you want to set to the lower border value (the number assigned in order from the left edge assuming that the number of the leftmost measurement point is 1)
Range	1 to the number of points
Initial value	1
Resolution	1

If the specified parameter is out of the allowable setting range, the minimum value (if the lower limit of the range is not reached) or the maximum value (if the upper limit of the range is exceeded) is set.

**Query response** {numeric}<newline><^END>

**Corresponding key** No front panel key is available to execute this function.

## SEARNG

**Syntax** SEARNG {FULL|SEGMENT}  
SEARNG?

**Description** For the active trace (set with the “TRAC” command on page 444), sets the search range for the list sweep: all segments (entire sweep range) or a single segment. To specify a segment when the search range is set to a single segment, use the “SEGMNUM” command on page 423.

**Parameters**

	Description
FULL (initial value)	Specifies all segments as the search range.
SEGMENT	Specifies a single segment as the search range.

**Query response** {FULL|SEGMENT}<newline><^END>

**Corresponding key** [Search] - SEARCH RANGE MENU - {FULL | SEGMENT}

## SEATARG

**Syntax** SEATARG <numeric>[DEG|RAD|OHM|SIE|H|F|PCT]  
 SEATARG?

**Description** For the active trace (set with the “TRAC” command on page 444), sets the target value (value in the Y axis direction) when performing the target search in the marker search function. In the  $\Delta$  marker mode, the value set with this command is dealt as a relative value from the  $\Delta$  marker. Therefore, to set the target value, use a relative value from the  $\Delta$  marker.

**Parameters**

	<b>&lt;numeric&gt;</b>
Description	Target value at the execution of the target search
Range	-100M to 100M
Initial value	0
Unit	Varies depending on the measurement parameter (refer to the explanation of unit in “SCAL” on page 410).

If the specified parameter is out of the allowable setting range, the minimum value (if the lower limit of the range is not reached) or the maximum value (if the upper limit of the range is exceeded) is set.

**Query response** {numeric}<newline><^END>

**Corresponding key** [Search] - TARGET - TARGET VALUE

## SEATARGL

**Syntax** SEATARGL {ON|OFF|1|0}  
 SEATARGL?

**Description** For the active trace (set with the “TRAC” command on page 444), enables/disables the display of the line indicating the target value (target line) when performing the target search in the marker search function.

**Parameters**

	<b>Description</b>
ON or 1	Enables the display of the target line.
OFF or 0 (initial value)	Disables the display of the target line.

**Query response** {1|0}<newline><^END>

**Corresponding key** [Search] - TARGET - LINE on OFF



## SEDI

**Syntax** SEDI [<numeric>]

**Description** In the creation/edit of the list sweep table, starts the edit of the segment specified as the edit target (set with the “SEGM” command on page 422). Note that, if a segment is specified, the edit target segment is changed to the specified segment and then the edit is started.

After the completion of the parameter setting of the segment, execute the “SDON” command on page 413 to finish the edit work. After executing this command and the “SADD” command on page 402 (to start segment edit), executing this command, without executing the “SDON” command, causes an error and the command is ignored.

If the creation/edit of the list sweep table has not been started, executing this command automatically starts table creation/edit and then starts the edit of the segment. (No query)

### Parameters

	<numeric>
Description	Segment number you want to edit
Range	1 to the number of segments in the list sweep table
Resolution	1

If the specified parameter is out of the allowable setting range, the minimum value (if the lower limit of the range is not reached) or the maximum value (if the upper limit of the range is exceeded) is set.

**Corresponding key** [Sweep] - EDIT LIST - EDIT >

## **SEGM**

**Syntax** SEGM <numeric>

SEGM?

**Description** Sets the execution target segment used when no segment is specified at the execution of the “SADD” command on page 402, “SDEL” command on page 412 and “SEDI” command on page 421. The setting of the execution target segment, when the creation/edit of the list sweep table is finished, is initialized.

If the creation/edit of the list sweep table is not started, executing this command automatically starts table creation/edit and then sets the execution target segment.

### **Parameters**

	<b>&lt;numeric&gt;</b>
Description	Segment number you want to specify as the edit target
Range	1 to the number of segments in the list sweep table
Initial value	Segment number of the last line in the list sweep table
Resolution	1

If the specified parameter is out of the allowable setting range, the minimum value (if the lower limit of the range is not reached) or the maximum value (if the upper limit of the range is exceeded) is set.

**Query response** {numeric}<newline><^END>

If the creation/edit of the list sweep table is not started, 0 is always read out.

**Corresponding key** [Sweep] - EDIT LIST - SEGMENT

## SEGMNUM

**Syntax** SEGMNUM <numeric>  
 SEGMNUM?

**Description** For the active trace (set with the “TRAC” command on page 444), if the search range is set to a segment for the list sweep (specified to SEGMENT with the “SEARNG” command on page 419), sets a segment as the search range.

**Parameters**

	<numeric>
Description	Segment number of the search range
Range	1 to the number of segments in the list sweep table
Initial value	1
Resolution	1

If the specified parameter is out of the allowable setting range, the minimum value (if the lower limit of the range is not reached) or the maximum value (if the upper limit of the range is exceeded) is set.

**Query response** {numeric}<newline><^END>

**Corresponding key** [Search] - SEARCH RANGE MENU - SEGMENT NUMBER

## SETCDATE

**Syntax** SETCDATE <year>,<month>,<day>  
 SETCDATE?

**Description** Sets the date of the built-in clock of the 4294A.

**Parameters**

	<year>	<month>	<day>
Description	Year	Month	Day
Range	1900 to 2099	1 to 12	1 to 31
Resolution	1	1	1

If the specified parameter is out of the allowable setting range, the minimum value (if the lower limit of the range is not reached) or the maximum value (if the upper limit of the range is exceeded) is set.

**Query response** {year},{month},{day}<newline><^END>

**Corresponding key** [System] - CLOCK - DATE ►

## SETCTIME

**Syntax** SETCTIME <hour>,<min>,<sec>  
 SETCTIME?

**Description** Sets the time of the built-in clock of the 4294A.

**Parameters**

	<hour>	<min>	<sec>
Description	Time (24 hours)	Minute	Second
Range	0 to 23	0 to 59	0 to 59
Resolution	1	1	1

If the specified parameter is out of the allowable setting range, the minimum value (if the lower limit of the range is not reached) or the maximum value (if the upper limit of the range is exceeded) is set.

**Query response** {hour},{min},{sec}<newline><^END>

**Corresponding key** [System] - **CLOCK - TIME** ►

## SIMFCHAR

**Syntax** SIMFCHAR

**Description** Executes the simulation of the frequency characteristic of the equivalent circuit. (No query)

**Corresponding key** [Display] - **more 1/2 - EQUIV CKT - SIMULATE F-CHRST**

## SING

**Syntax** SING

**Description** Performs a single sweep. After the sweep, the sweep mode goes to HOLD. (No query)

**Corresponding key** [Trigger] - **SINGLE**

## SMKR{1-7}

**Syntax** SMKR{1|2|3|4|5|6|7} {ON|OFF|1|0}  
SMKR{1|2|3|4|5|6|7}?

**Description** For the active trace (set with the “TRAC” command on page 444), turns on/off a sub marker (marker number 1 to 7). In the coupled marker mode (set with the “MKRCOUP” command on page 341), the setting is applied to both the A and B traces regardless of the active trace setting. The sub marker set to on with this command is displayed at the same position as the marker. If the marker function is off, executing this command causes an error and the command is ignored.

**Parameters**

	Description
ON or 1	Turns on a sub marker.
OFF or 0 (initial value)	Turns off a sub marker.

**Query response** {ON|OFF|1|0}<newline><^END>

**Corresponding key** [Marker] - SUB MKR - {1: OFF | 2: OFF | 3: OFF | 4: OFF | 5: OFF | 6: OFF | 7: OFF}  
[Marker] - CREAM SUB MKR - {1: OFF | 2: OFF | 3: OFF | 4: OFF | 5: OFF | 6: OFF | 7: OFF}

## SMKRAUV{1-7}?

**Syntax** SMKRAUV{1|2|3|4|5|6|7}?

**Description** For the active trace (set with the “TRAC” command on page 444), if the measurement parameter is a vector value (for COMPLEX Z-Y), reads out the subsidiary readout of the measurement parameter value at the sub marker position (marker number 1 to 7). (Query only)

**Query response** {numeric}<newline><^END>

If the measurement parameter is a scalar value (for other than COMPLEX Z-Y), 0 is always read out. If the measurement parameter is a vector value (for COMPLEX Z-Y), the readout is as follows:

- If the polar chart format is selected, the phase is read out.
- If the complex plane format is selected, reactance (for trace A) or susceptance (for trace B) is read out.

**Corresponding key** No front panel key is available to execute this function.

## **SMKRP{1-7}**

**Syntax** SMKRP{1|2|3|4|5|6|7} <numeric>  
SMKRP{1|2|3|4|5|6|7}?

**Description** For the active trace (set with the “TRAC” command on page 444), moves a sub marker (marker number 1-7) to the specified measurement point. In the coupled marker mode (set with the “MKRCOUP” command on page 341), regardless of the active trace setting, moves the sub marker on both the A and B traces. If this command is executed as Query, it reads out the measurement point number at the sub marker position. If the sub marker is off, executing this command causes an error and the command is ignored.

### **Parameters**

	<b>&lt;numeric&gt;</b>
Description	Number of the measurement point where you want to move the sub marker (the number assigned in order from the left edge assuming that the number of the leftmost measurement point is 1)
Range	1 to the number of points
Initial value	1
Resolution	1

If the specified parameter is out of the allowable setting range, the minimum value (if the lower limit of the range is not reached) or the maximum value (if the upper limit of the range is exceeded) is set.

**Query response** {numeric}<newline><^END>

**Corresponding key** No front panel key is available to execute this function.

## SMKRPRM{1-7}

**Syntax** SMKRPRM{1|2|3|4|5|6|7} <numeric>[HZ|MHZ|V|A]  
 SMKRPRM{1|2|3|4|5|6|7}?

**Description** For the active trace (set with the “TRAC” command on page 444), moves a sub marker (marker number 1-7) to the position of the specified sweep parameter value. In the coupled marker mode (set with the “MKRCOUP” command on page 341), regardless of the active trace setting, moves the sub marker on both the A and B traces. If this command is executed as Query, it reads out the sweep parameter value of the sub marker position.

If the  $\Delta$  marker mode is on, the sub marker moves the distance of the specified sweep parameter value relative to the  $\Delta$  marker. Therefore, specify the position where you want to move the sub marker by the difference from the  $\Delta$  marker. Also, the readout, when executed as query, is the difference value from the  $\Delta$  marker.

If the sub marker is off, executing this command causes an error and the command is ignored.

**Parameters**

	<b>&lt;numeric&gt;</b>
Description	Position where you want to move the sub marker
Range	“Sweep start value” to “sweep stop value”
Initial value	0
Unit	Varies depending on the sweep parameter (refer to the explanation of unit in “CENT” on page 269).
Resolution	Varies depending on the sweep parameter (refer to the explanation of resolution in “CENT” on page 269).

If the specified parameter is out of the allowable setting range, the minimum value (if the lower limit of the range is not reached) or the maximum value (if the upper limit of the range is exceeded) is set.

**Query response** {numeric}<newline><^END>

**Corresponding key** No front panel key is available to execute this function.

**SMKRVAL{1-7}?**

<b>Syntax</b>	SMKRVAL {1 2 3 4 5 6 7}?
<b>Description</b>	For the active trace (set with the “TRAC” command on page 444), reads out the measurement parameter value at a sub marker (marker number 1-7) position. (Query only)
<b>Query response</b>	{numeric}<newline><^END>  If the measurement parameter is a scalar value (for other than COMPLEX Z-Y), the measurement parameter value is read out. If the measurement parameter is a vector value (for COMPLEX Z-Y), the readout is as follows: <ul style="list-style-type: none"><li>• If the polar chart format is selected, the amplitude is read out.</li><li>• If the complex plane format is selected, resistance (for trace A) or conductance (for trace B) is read out.</li></ul>
<b>Corresponding key</b>	No front panel key is available to execute this function.



## SPAN

**Syntax** SPAN <numeric>[HZ|MHZ|V|A]  
SPAN?

**Description** Sets the span value of the sweep range. To set the span value of each segment when creating the list sweep table, also use this command.

### Parameters

		<numeric>
Description		Span value
When the sweep parameter is frequency	Range	0 to 109.99996E6 (for linear sweep) 20 to 109.99996E6 (for log sweep)
	Initial value	109.99996E6
	Unit	Hz
	Resolution	1E-3
When the sweep parameter is OSC level (voltage)	Range	0 to 0.995
	Initial value	0.995
	Unit	V (volt)
	Resolution	1E-3
When the sweep parameter is OSC level (current)	Range	0 to 19.8E-3
	Initial value	19.8E-3
	Unit	A (ampere)
	Resolution	10E-6
When the sweep parameter is dc bias level (voltage)	Range	0 to 80
	Initial value	0
	Unit	V (volt)
	Resolution	1E-3
When the sweep parameter is dc bias level (current)	Range	0 to 200E-3
	Initial value	0
	Unit	A (ampere)
	Resolution	10E-6

Note that, if you use this command to create a segment, the initial value is 0 regardless of the sweep parameter.

If the specified parameter is out of the allowable setting range, the minimum value (if the lower limit of the range is not reached) or the maximum value (if the upper limit of the range is exceeded) is set.

**Query response** {numeric}<newline><^END>

**Corresponding key** [Span]

## **SPLD**

**Syntax**           SPLD {ON|OFF|1|0}  
                  SPLD?

**Description**       Enables/disables the vertically separate display for traces A and B.

If the separate display of traces A and B is enabled, the upper half of the LCD screen is used as trace A measurement result display screen, and the lower half, as trace B measurement result display screen. If the separate display of traces A and B is disabled, the measurement results of traces A and B are superimposed on the same screen.

If the screen is set so that the upper half of the LCD screen is used as the measurement result display screen and the lower half as the HP Instrument BASIC screen (specified to HIHB with the “DISA” command on page 288), regardless of the setting to enable/disable the separate display, both traces are superimposed on the same screen.

### **Parameters**

	<b>Description</b>
ON or 1	Enables the separate display of traces A and B.
OFF or 0 (initial value)	Disables the separate display of traces A and B.

**Query response**    {1|0}<newline><^END>

**Corresponding key**   **[Display] - SPLIT on OFF**

## STAR

**Syntax** STAR <numeric>[HZ|MHZ|V|A]  
 STAR?

**Description** Sets the sweep range start value.

**Parameters**

		<numeric>
Description		start value
When the sweep parameter is frequency	Range	40 to 110E6 (for linear sweep) 40 to 109.9998E6 (for log sweep)
	Initial value	40
	Unit	Hz
	Resolution	1E-3
When the sweep parameter is OSC level (voltage)	Range	5E-3 to 1
	Initial value	5E-3
	Unit	V (volt)
	Resolution	1E-3
When the sweep parameter is OSC level (current)	Range	200E-6 to 20E-3
	Initial value	200E-6
	Unit	A (ampere)
	Resolution	10E-6
When the sweep parameter is dc bias level (voltage)	Range	-40 to 40
	Initial value	0
	Unit	V (volt)
	Resolution	1E-3
When the sweep parameter is dc bias level (current)	Range	-100E-3 to 100E-3
	Initial value	0
	Unit	A (ampere)
	Resolution	10E-6

Note that, if you use this command to create a segment, the initial value when creating segment 1 is the current sweep range start value and the initial value when creating an additional segment is the sweep range stop value of the previous segment.

If the specified parameter is out of the allowable setting range, the minimum value (if the lower limit of the range is not reached) or the maximum value (if the upper limit of the range is exceeded) is set.

**Query response** {numeric}<newline><^END>

**Corresponding key** [Start]

## **STOD**

**Syntax** STOD {DISK|MEMO|FLASH}

**Description** Selects a mass storage to which file operation is applied. (No query)

**Parameters**

	<b>Description</b>
DISK (initial value)	Specifies the flexible disk drive.
MEMO	Specifies the built-in RAM disk (volatile).
FLASH	Specifies the built-in flash disk (non-volatile).

**Corresponding key** [Save] - STORE DEV [ ] - {FLOPPY | MEMORY | FLASH MEMORY}

## STOP

**Syntax**                STOP <numeric>[HZ|MHZ|V|A]  
STOP?

**Description**        Sets the sweep range stop value.

**Parameters**

		<numeric>
Description		Stop value
When the sweep parameter is frequency	Range	40 to 110E6 (for linear sweep) 60 to 110E6 (for log sweep)
	Initial value	110E6
	Unit	Hz
	Resolution	1E-3
When the sweep parameter is OSC level (voltage)	Range	5E-3 to 1
	Initial value	1
	Unit	V (volt)
	Resolution	1E-3
When the sweep parameter is OSC level (current)	Range	200E-6 to 20E-3
	Initial value	20E-3
	Unit	A (ampere)
	Resolution	10E-6
When the sweep parameter is dc bias level (voltage)	Range	-40 to 40
	Initial value	0
	Unit	V (volt)
	Resolution	1E-3
When the sweep parameter is dc bias level (current)	Range	-100E-3 to 100E-3
	Initial value	0
	Unit	A (ampere)
	Resolution	10E-6

Note that, if you use this command to create a segment, the initial value when creating segment 1 is the current sweep range start value and the initial value when creating an additional segment is the sweep range stop value of the previous segment.

If the specified parameter is out of the allowable setting range, the minimum value (if the lower limit of the range is not reached) or the maximum value (if the upper limit of the range is exceeded) is set.

**Query response**    {numeric}<newline><^END>

**Corresponding key**    [Stop]

## SUBNET

**Syntax** SUBNET <1st>,<2nd>,<3rd>,<4th>  
 SUBNET?

**Description** When using the 4294A connected to LAN, sets the subnet mask for IP address. The value actually used as the subnet mask is the logical OR of the value set with this command and the value determined depending on the IP address of the 4294A as shown below.

IP address	Value used for OR
0.0.0.0-127.255.255.255 (class A)	255.0.0.0
128.0.0.0-191.255.255.255 (class B)	255.255.0.0
192.0.0.0-223.255.255.255 (class C)	255.255.255.0

For example, if the IP address of the 4294A is 150.100.10.1 and the value set with this command is 0.0.192.0, the value actually used as the subnet mask is 255.255.192.0.

**NOTE** To bring the setting of the changed subnet mask to take effect, reboot (turn off and then on again) the 4294A after the setting.

### Parameters

	<1st>*1	<2nd>*1	<3rd>*1	<4th>*1
Description	1st number of the subnet mask	2nd number of the subnet mask	3rd number of the subnet mask	4th number of the subnet mask
Range	0 to 255	0 to 255	0 to 255	0 to 255
Initial value	0	0	0	0
Resolution	1	1	1	1

\*1.For example, to set the subnet mask to 255.255.192.0, <1st> is 255, <2nd> is 255, <3rd> is 192, and <4th> is 0.

If the specified parameter is out of the allowable setting range, the minimum value (if the lower limit of the range is not reached) or the maximum value (if the upper limit of the range is exceeded) is set.

**Query response** {1st},{2nd},{3rd},{4th}<newline><^END>

**Corresponding key** [Local] - SUBNET MASK - 1st, 2nd, 3rd, 4th

## SWED

**Syntax** SWED {UP|DOWN}  
 SWED?

**Description** Selects the sweep direction.

**Parameters**

	Description
UP (initial value)	Specifies the sweep parameter increasing direction (from left to right on the screen).
DOWN	Specifies the sweep parameter decreasing direction (from right to left on the screen).

**Query response** {UP|DOWN}<newline><^END>

**Corresponding key** [Sweep] - DIRECTION [ ]

## SWET

**Syntax** SWET <numeric>[S]  
 SWET?

**Description** Sets the sweep time.

**Parameters**

	<numeric>
Description	Sweep time
Range	0 to 10000 (Note that, the lower limit varies depending on the measurement condition.)
Initial value	Varies depending on the measurement condition.
Unit	s (second)
Resolution	0.001

If the specified parameter is out of the allowable setting range, the minimum value (if the lower limit of the range is not reached) or the maximum value (if the upper limit of the range is exceeded) is set.

**Query response** {numeric}<newline><^END>

**Corresponding key** [Sweep] - TIME - SWEEP TIME

## **SWPP**

**Syntax** SWPP {FREQ|OLEV|DCB}  
SWPP?

**Description** Sets the sweep parameter.

### **Parameters**

	<b>Description</b>
FREQ (initial value)	Specifies the frequency sweep.
OLEV	Specifies the oscillator (OSC) level sweep.
DCB	Specifies the dc bias level sweep.

**Query response** {FREQ|OLEV|DCB}<newline><^END>

**Corresponding key** [Sweep] - PARAMETER [ ] - {FREQ | OSC LEVEL | DC BIAS}

## **SWPT**

**Syntax** SWPT {LIN|LOG|LIST}  
SWPT?

**Description** Sets the sweep type.

### **Parameters**

	<b>Description</b>
LIN (initial value)	Specifies the linear sweep.
LOG	Specifies the log sweep (settable only for frequency sweep).
LIST	Specifies the list sweep.

**Query response** {LIN|LOG|LIST}<newline><^END>

**Corresponding key** [Sweep] - TYPE [ ] - {LINEAR | LOG | LIST}



## TARL?

**Syntax** TARL? <numeric 1>

**Description** Within the waveform analysis range specified with the “ANARANG” command on page 259, searches the analysis range from right to left for a point of the specified measurement value, and reads out the sweep parameter value at the first detected point. If the specified measurement parameter value is not detected, 0 is read out.(Query only)

**Parameters**

	<b>&lt;numeric 1&gt;</b>
Description	Measurement parameter value you want to search for
Range	-9.9E37 to 9.9E37
Unit	Varies depending on the measurement parameter (refer to the explanation of unit in “SCAL” on page 410).

If the specified parameter is out of the setting range, an error occurs and the command is ignored.

**Query response** {numeric 2}<newline><^END>

	<b>{numeric 2}</b>
Description	Sweep parameter value of the detected point
Unit	Varies depending on the sweep parameter (refer to the explanation of unit in “CENT” on page 269).

**Corresponding key** No front panel key is available to execute this function.

**TARR?**

**TARR?**

**Syntax** TARR? <numeric 1>

**Description** Within the waveform analysis range specified with the “ANARANG” command on page 259, searches the analysis range from left to right for a point of the specified measurement value, and reads out the sweep parameter value at the first detected point. If the specified measurement parameter value is not detected, 0 is read out.(Query only)

**Parameters**

	<b>&lt;numeric 1&gt;</b>
Description	Measurement parameter value you want to search for
Range	-9.9E37 to 9.9E37
Unit	Varies depending on the measurement parameter (refer to the explanation of unit in “SCAL” on page 410).

If the specified parameter is out of the setting range, an error occurs and the command is ignored.

**Query response** {numeric 2}<newline><^END>

	<b>{numeric 2}</b>
Description	Sweep parameter value of the detected point
Unit	Varies depending on the sweep parameter (refer to the explanation of unit in “CENT” on page 269).

**Corresponding key** No front panel key is available to execute this function.

## THRR

**Syntax** THRR <numeric>  
 THRR?

**Description** Within the waveform analysis range specified with the “ANARANG” command on page 259, sets the condition on which peaks are defined among all maximal values and negative peaks are defined among all minimal values: *height* (refer to Figure 16-7).

**Figure 16-7** Condition of the peak/negative peak

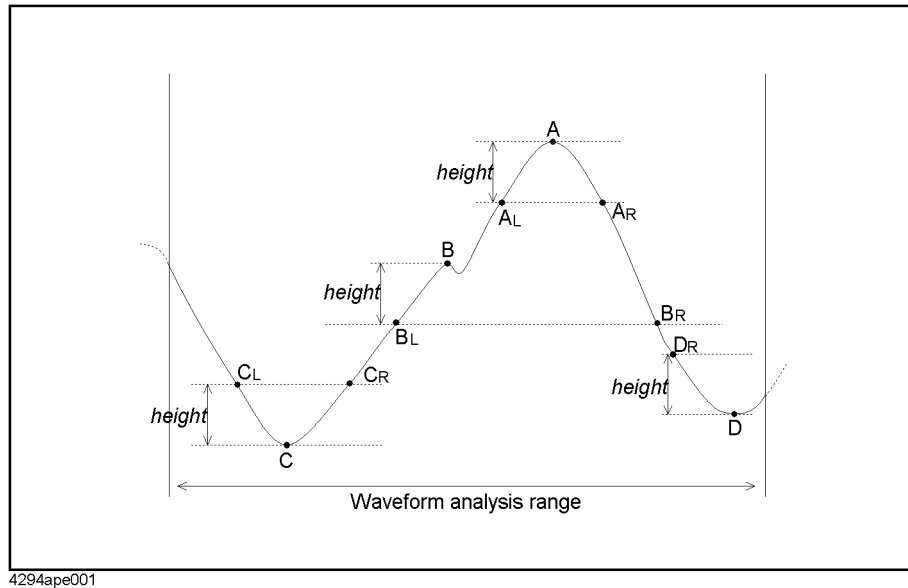

If 2 measurement points having a value less than the maximal value minus *height* exist on both left and right sides of a maximal value, and the maximal value is the maximum within the range between those measurement points, it is considered as a peak. For example, for maximal value A in Figure 16-7, there are 2 points on both left and right sides having a value less than the maximal value minus *height*: measurement point A<sub>L</sub> and A<sub>R</sub>, and A is the maximum within the range between A<sub>L</sub> and A<sub>R</sub>. Therefore, it is considered as a peak. On the other hand, for maximal value B, there are 2 points on both left and right sides having a value less than the maximal value minus *height*: measurement point B<sub>L</sub> and B<sub>R</sub>, but B is not the maximum within the range between B<sub>L</sub> and B<sub>R</sub>. Therefore, it is not considered as a peak.

In the same way, if 2 measurement points having a value of the minimal value plus *height* exist on both left and right sides of a minimal value, and the minimal value is the minimum within the range between those measurement points, it is considered as a negative peak. For example, for minimal value C in Figure 16-7, there are 2 points on both left and right sides having a value larger than the minimal value plus *height*: measurement point C<sub>L</sub> and C<sub>R</sub>, and C is the minimum within the range between C<sub>L</sub> and C<sub>R</sub>, it is considered as a negative peak. For minimal value D, there is no measurement point on the right side having a value larger than the minimal value plus *height*, it is not considered as a negative peak.

Depending on the display format, the definition of *height* differs as shown below (in the previous description, a measurement point having a value less than the maximal value minus *height* (or a value larger than the minimal value plus *height*) means a threshold value

16: GPIB  
 Command Reference  
 (S-Z, :PROG)

THRR

for the linear Y axis format.)

For the linear Y axis format

*height* is a threshold value of the distance between the maximal value (or minimal value) and the measurement point value (in Figure 16-7, value of  $|A-A_L|$ ,  $|C-C_R|$ , and so on).

For the log Y axis format

*height* is a threshold value of the ratio of the larger value to the smaller value: maximal value (or minimal value) and measurement point value (in Figure 16-7, values of  $A/A_L$  and  $C_R/C$ , and so on). More specifically, the threshold value shown below.

When  $H > 0, L > 0$ :  $H / L$

When  $H < 0, L < 0$ :  $L / H$  (for negative values, a larger value has a smaller absolute value, and therefore the denominator and numerator are reversed.)

When  $H \geq 0, L \leq 0$ : No peak and negative peak are detected. Note that, only when the value of *height* is 1 (initial value), all maximal values (or minimal values) are considered as peaks (or negative peaks).

Where, H is the larger value and L is the smaller value. More specifically, when judging whether a maximal value is a peak, H is the maximal value and L is the measurement point value. When judging whether a minimal value is a negative peak, H is the measurement point value and L is the minimal value.

For the linear Y axis format, if *height* is set to 0 (initial value), all maximal values (or minimal values) are considered as peaks (or negative peaks). On the other hand, for the log Y axis format, if *height* is set to 1 (initial value), all maximal values (or minimal values) are considered as peaks (or negative peaks).

Parameters

	<numeric>
Description	Condition of the peak/negative peak: <i>height</i>
Range	For the linear Y axis format: 0 to 9.9E37 For the log Y axis format: 1 to 9.9E37
Initial value	For the linear Y axis format: 0 For the log Y axis format: 1
Unit	Varies depending on the measurement parameter (refer to the explanation of unit in “SCAL” on page 410).

If the specified parameter does not reach the lower limit of the setting range, it is set to the lower limit. If the specified parameter exceeds the upper limit of the setting range, an error occurs and the command is ignored.

Query response {numeric}<newline><^END>

Corresponding key No front panel key is available to execute this function.

## TINT

**Syntax** TINT <numeric>  
TINT?

**Description** Sets the hue of the display color of the item selected with the “COLO” command on page 272 command.

**Parameters**

	<numeric>
Description	Value indicating the hue (0 or 100: red, 33: green, 66: blue)
Range	0 to 100
Initial value	Varies depending on the display item selected with the “COLO” command on page 272.
Resolution	1

If the specified parameter is out of the allowable setting range, the minimum value (if the lower limit of the range is not reached) or the maximum value (if the upper limit of the range is exceeded) is set.

**Query response** {numeric}<newline><^END>

**Corresponding key** [Display] - more 1/2 - MODIFY COLOR - MODIFY ITEM COLOR - MODIFY COLOR  
- TINT

## TITL

**Syntax** TITL <string>  
TITL?

**Description** For the active trace (set with the “TRAC” command on page 444), sets a string displayed in the title area on the display screen.

**Parameters**

	<string>
Description	String displayed in the title area
Range	65 characters or less
Initial value	Blank (“”)

If the specified file name has characters that exceed the maximum length, only the string of up to the maximum length is valid and the remaining characters are ignored.

**Query response** {string}<newline><^END>

**Corresponding key** [Display] - more 1/2 - TITLE ►

## **TMARG**

**Syntax** TMARG <numeric>  
TMARG?

**Description** Sets the top margin (white space) of printed forms for printout.

**Parameters**

	<b>&lt;numeric&gt;</b>
Description	Top margin
Range	0 to 5
Initial value	1
Unit	inch
Resolution	0.01

If the specified parameter is out of the allowable setting range, the minimum value (if the lower limit of the range is not reached) or the maximum value (if the upper limit of the range is exceeded) is set.

**Query response** {numeric}<newline><^END>

**Corresponding key** [Copy] - SETUP - TOP MARGIN

## TOPV

**Syntax** TOPV <numeric>[OHM|DEG|RAD|SIE|H|F|PCT]  
TOPV?

**Description** Sets the maximum value of the display screen in the Y axis (vertical axis) direction (value of the top of the grid).

If the difference, between this maximum value and the minimum value in the Y-axis direction on the display screen (set with the “BOTV” command on page 265), is less than 10E-15 (for the log Y axis format, the ratio between the maximum value and the minimum value is less than 5), the minimum value is automatically changed so that it is less than the maximum value minus 10E-15 (for the log Y axis format, the value at which the ratio between the maximum value and the minimum value is 5). Also, the single grid tick width (SCALE/DIV) and the reference line value (REFERENCE VALUE) are automatically changed so that they match the setting of the minimum value/maximum value in the Y-axis direction.

In the log Y axis format, if the sign differs from that of the display screen minimum value, the sign of the minimum value is automatically changed to the same sign as the maximum value.

### Parameters

	<numeric>
Description	Maximum value of the display screen in the Y axis (vertical axis) direction
Range	Varies depending on the measurement parameter as follows: For  Z , R, X: -1E12 to 1E12 For other than  Z , R, X: -1E9 to 1E9
Initial value	Varies depending on the measurement parameter as follows: For  Z , R, X, Rs, Rp: 1E6 For $\theta$ : 180 For  Y , G, B, D: 1 For Cs, Cp: 1E-3 For Ls, Lp: 10 For Q: 1E3
Unit	Varies depending on the measurement parameter (refer to the explanation of unit in “SCAL” on page 410).
Resolution	1E-15 *1

\*1. This is the minimum value (when the set value is small). The resolution becomes larger as the set value becomes larger.

If the specified parameter is out of the allowable setting range, the minimum value (if the lower limit of the range is not reached) or the maximum value (if the upper limit of the range is exceeded) is set.

**Query response** {numeric}<newline><^END>

**Corresponding key** [Scale Ref] - TOP VALUE

## TRAC

**Syntax** TRAC {A|B}  
TRAC?

**Description** Sets the active trace.

### Parameters

	Description
A (initial value)	Specifies trace A as the active trace.
B	Specifies trace B as the active trace.

**Query response** {A|B}<newline><^END>

**Corresponding key** {[A] | [B]}

## TRACK

**Syntax** TRACK {ON|OFF|1|0}  
TRACK?

**Description** For the active trace (set with the “TRAC” command on page 444), toggles on and off the search tracking function.

### Parameters

	Description
ON or 1	Turns on the search tracking function.
OFF or 0 (initial value)	Turns off the search tracking function.

**Query response** {1|0}<newline><^END>

**Corresponding key** [Search] - SEARCH TRK on OFF



## TRGEVE

**Syntax** TRGEVE {SWE|POIN}  
 TRGEVE?

**Description** Sets the mode of trigger events.

**Parameters**

	Description
SWE (initial value)	Specifies the mode in which each trigger performs a single sweep (if the averaging function is on, a set number of times as the averaging count).
POIN	Specifies the mode in which each trigger performs the measurement of a single measurement point.

**Query response** {SWE|POIN}<newline><^END>

**Corresponding key** [Trigger] - SOURCE [ ] - EVENT [ ]

## TRGP

**Syntax** TRGP {POS|NEG}  
 TRGP?

**Description** Sets the polarity of the external trigger signal inputted from the EXT TRIGGER terminal on the rear panel.

**Parameters**

	Description
POS (initial value)	Specifies positive (generating a trigger at a rise from the LOW level to the HIGH level).
NEG	Specifies negative (generating a trigger at a fall from the HIGH level to the LOW level).

**Query response** {POS|NEG}<newline><^END>

**Corresponding key** [Trigger] - SOURCE [ ] - EXT POLRTY [ ]

## TRGS

**Syntax** TRGS {INT|EXT|BUS|MAN}  
 TRGS?

**Description** Selects a trigger source.

**Parameters**

	Description
INT (initial value)	Specifies the internal trigger.
EXT	Specifies the external trigger inputted from the EXT TRIGGER terminal on the rear panel.
BUS	Specifies the GPIB/LAN trigger (trigger by executing the “*TRG” command on page 253).
MAN	Specifies the manual trigger (trigger by the following key sequence on the front panel: <b>[Trigger] - SOURCE [ ] - MANUAL</b> ).

**Query response** {INT|EXT|BUS|MAN}<newline><^END>

**Corresponding key** **[Trigger] - SOURCE [ ] - {FREE RUN | EXTERNAL | HP-IB/LAN | MANUAL}**

## USKEY

**Syntax** USKEY

**Description** Displays user keys (ON KEY LABELS) of Instrument BASIC. (No query)

**Corresponding key** **[System] - IBASIC - ON KEY LABELS**

## WIDFVAL

**Syntax** WIDFVAL <numeric>[OHM|DEG|RAD|SIE|H|F|PCT]  
WIDFVAL?

**Description** For the active trace (set with the “TRAC” command on page 444), if the free cutoff value setting is enabled (specified to FIXEd with the “WIDVTYPE” command on page 449), sets a cutoff point. If Δmaker is on, the cutoff value is set the result of subtracting the specified value from the measurement parameter value of Δmaker position.

**Parameters**

	<numeric>
Description	Cutoff value *1
Range	-100E6 to 100E6
Initial value	0
Unit	Varies depending on the measurement parameter (refer to the explanation of unit in “SCAL” on page 410).

\*1.If the measurement parameter is a vector value (for COMPLEX Z-Y) and if the polar chart format is selected, set the value in amplitude. If the complex plane format is selected, set the value in resistance (for trace A) or conductance(for trace B).

If the specified parameter is out of the allowable setting range, the minimum value (if the lower limit of the range is not reached) or the maximum value (if the upper limit of the range is exceeded) is set.

**Query response** {numeric}<newline><^END>

**Corresponding key** [Search] - WIDTHS DEF MENU - FIXED VALUE

## WIDSIN

**Syntax** WIDSIN

**Description** For the trace bandwidth analysis function for the active trace (set with the “TRAC” command on page 444), further searches for another cutoff point inside the already detected cutoff point. If no cutoff point is detected, the message indicating the result is displayed (no error occurs). If the trace bandwidth analysis function is off, executing this command causes an error and the command is ignored. (No query)

**Corresponding key** [Search] - WIDTHS DEF MENU - SEARCH IN

## WIDSOUT

**Syntax** WIDSOUT

**Description** For the trace bandwidth analysis function for the active trace (set with the “TRAC” command on page 444), further searches for another cutoff point outside the already detected cutoff point. If no cutoff point is detected, the message indicating the result is displayed (no error occurs). If the trace bandwidth analysis function is off, executing this command causes an error and the command is ignored. (No query)

**Corresponding key** [Search] - WIDTHS DEF MENU - SEARCH OUT

## WIDT

**Syntax** WIDT {ON|OFF|1|0}  
WIDT?

**Description** For the active trace (set with the “TRAC” command on page 444), toggles on and off the trace bandwidth analysis function. If the trace bandwidth analysis function is set to on and If no bandwidth can be detected, the message indicating the result is displayed (no error occurs). If the marker function is off, executing this command causes an error and the command is ignored.

### Parameters

	Description
ON or 1	Turns on the trace bandwidth analysis function.
OFF or 0 (initial value)	Turns off the trace bandwidth analysis function.

**Query response** {1|0}<newline><^END>

**Corresponding key** [Search] - WIDTHS on OFF

## WIDVTYPE

**Syntax**            WIDVTYPE {DIVS2|MULS2|DIV2|FIXed}  
WIDVTYPE?

**Description**        For the active trace (set with the “TRAC” command on page 444), selects the method to set a cutoff point in the trace bandwidth analysis function.

**Parameters**

	<b>Description</b>
DIVS2	The value obtained by dividing the measurement parameter value at the marker position by $\sqrt{2}$ is set as the cutoff point.
MULS2	The value obtained by multiplying the measurement parameter value at the marker position and $\sqrt{2}$ is set as the cutoff point.
DIV2	The value obtained by dividing the measurement parameter value at the marker position by 2 is set as the cutoff point.
FIXed (initial value)	Lets you set the cutoff point freely using the “WIDFVAL” command on page 447.

If the measurement parameter is a vector value (for COMPLEX Z-Y), you can select FIXed only.

**Query response**    {DIVS2|MULS2|DIV2|FIXed}<newline><^END>

**Corresponding key**    [Search] - WIDTHS DEF MENU - {MKRVAL/(\sqrt{2}) | MKRVAL\*(\sqrt{2}) | MKRVAL/2 | FIXED VALUE}

## **ZMAPER**

**Syntax** ZMAPER <numeric>[PCT]  
ZMAPER?

**Description** Sets the zooming aperture value in a percentage of the span value. If the marker function is off, executing this command causes an error and the command is ignored.

### **Parameters**

	<b>&lt;numeric&gt;</b>
Description	Zooming aperture value
Range	0.01 to 100
Initial value	10
Unit	% (percentage)
Resolution	0.01

If the specified parameter is out of the allowable setting range, the minimum value (if the lower limit of the range is not reached) or the maximum value (if the upper limit of the range is exceeded) is set.

**Query response** {numeric}<newline><^END>

**Corresponding key** [Marker→] - more 1/2 - ZOOMING APERTURE

## Instrument BASIC control commands

This section describes the commands used to control Instrument BASIC from the external controller. The commands described here cannot be executed using Instrument BASIC.

### **:PROGram:CATalog?**

- Syntax** :PROGram:CATalog?
- Description** Reads out the program name defined with the “:PROGram[:SELEcted]:NAME” command on page 453. The 4294A provides no practical function. (Query only)
- Corresponding key** No front panel key is available to execute this function.

### **:PROGram[:SELEcted]:DEFine**

- Syntax** :PROGram[:SELEcted]:DEFine <block>  
:PROGram[:SELEcted]:DEFine?
- Description** Downloads an HP Instrument BASIC program from the external controller to the 4294A. If the size of the downloaded program exceeds available space in the Instrument BASIC program workspace, lines of the program sent before the overflow are stored, and program lines sent after the overflow are ignored.
- Executing this command as a query uploads the Instrument BASIC program on the 4294A to the external controller. Uploading is available when the status of the program is PAUSE or STOP.

**Parameters**

	<b>&lt;block&gt;</b>
Description	Program data of arbitrary length block

Arbitrary length block data consists of a header part and a following data part (program to be sent). The header part has 2 formats as follows.

- #0 Indicates that the size of the data part is not defined. In this case, after sending the header part, data of an arbitrary size is sent. After all the data is sent, send an end signal (<LF>+EOI) (for example, in the case of HP BASIC, send END in an OUTPUT statement) to finish sending the data. Transmission in this format can be executed only from GPIB, but cannot from LAN.
- #NMM...M Defines the size of the data part (N specifies the number of digits of the number to indicate the size (the MM...M part); MM...M specifies the size). In this case, data of the defined size is sent, following the header part.

- Query response** {block}<newline><^END>  
Reads out a program in an arbitrary length block in which the header part defines the data size and the data part follows it.
- Corresponding key** No front panel key is available to execute this function.

**:PROGrama[:SElected]:DELeTe:ALL**

**Syntax** :PROGrama[:SElected]:DELeTe:ALL

**Description** Deletes all programs on the 4294A Instrument BASIC editor. (No query)

**Corresponding key** No front panel key is available to execute this function.

**:PROGrama[:SElected]:DELeTe:[SElected]**

**Syntax** :PROGrama[:SElected]:DELeTe:[SElected]

**Description** Deletes a program on the 4294A. (No query)

**Corresponding key** No front panel key is available to execute this function.

**:PROGrama[:SElected]:EXECute**

**Syntax** :PROGrama[:SElected]:EXECute <string>

**Description** Execute the specified program command. This command can be executed only when the status of the program is PAUSE or STOP. (No query)

**Parameters**

	<b>&lt;string&gt;</b>
Description	Command you want to execute

**Corresponding key** No front panel key is available to execute this function.

**:PROGrama[:SElected]:MALLocate**

**Syntax** :PROGrama[:SElected]:MALLocate {<numeric>|DEFault}  
:PROGrama[:SElected]:MALLocate?

**Description** The 4294A provides no practical function.

**Corresponding key** No front panel key is available to execute this function.



**:PROGram[:SELEcted]:NAME**

**Syntax** :PROGram[:SELEcted]:NAME <string>  
 :PROGram[:SELEcted]:NAME?

**Description** Defines a program name. Note that, in the case of the 4294A, you need not to define any program name.

**Parameters**

	<b>&lt;string&gt;</b>
Description	Program name
Initial value	"PROG"

**Corresponding key** No front panel key is available to execute this function.

**:PROGram[:SELEcted]:NUMBer**

**Syntax** :PROGram[:SELEcted]:NUMBer <variable name>,<numeric 1>[,<numeric 2>,...,<numeric n>]  
 :PROGram[:SELEcted]:NUMBer? <variable name>

**Description** Sets values into the specified numeric variable or numeric array of the program on the 4294AInstrument BASIC editor.

**Parameters**

	<b>Description</b>
<variable name>	Numeric variable name you want to specify. It does not need to be enclosed in double quotation marks (").
<numeric 1>	Value you want to set into the numeric variable. (If the numeric variable is an array, the 1st value of the array.)
<numeric n>	If the numeric variable is an array, the n-th value of the array.

**Query response** {numeric 1}[, {numeric 2},..., {numeric n}]<newline><^END>

**Corresponding key** No front panel key is available to execute this function.

**:PROGram[:SElected]:STATe**

**Syntax** :PROGram[:SElected]:STATe {RUN|PAUSE|STOP|CONTinue}  
:PROGram[:SElected]:STATe?

**Description** Sets the status of the program on the 4294A Instrument BASIC editor.

**Parameters**

	Description
RUN	Causes the program to run.
PAUSE	Causes the program to pause.
STOP	Causes the program to stop.
CONTinue	Causes the program in pause to run.

If the program is running and this command is executed with RUN specified, an error occurs and the command is ignored.

If the program is stopped and this command is executed with PAUSE specified, the program remains stopped.

If the program is in a status other than PAUSE and this command is executed with CONTinue specified, an error occurs and the command is ignored.

**Query response** {RUN|PAUS|STOP}<newline><^END>

**Corresponding key** No front panel key is available to execute this function.

**:PROGram[:SElected]:STRing**

**Syntax** :PROGram[:SElected]:STRing <variable name>,<string 1>[,<string 2>,...,<string n>]  
:PROGram[:SElected]:STRing? <variable name>

**Description** Sets a value into the specified string variable or numeric array in the program on the 4294A Instrument BASIC editor.

**Parameters**

	Description
<variable name>	Numeric variable name you want to specify. \$ at the end of a variable name is not needed. It does not need to be enclosed in double quotation marks (").
<string 1>	String you want to set into the string variable. (If the numeric variable is an array, the 1st value of the array.) It must be enclosed in double quotation marks (").
<string n>	When the string variable is an array, the n-th string of the array. It must be enclosed in double quotation marks (").

**Query response** {string 1}[, {string 2} ,..., {string n}]<newline><^END>

**Corresponding key** No front panel key is available to execute this function.

## :PROGram[:SELEcted]:WAIT

<b>Syntax</b>	:PROGram[:SELEcted]:WAIT :PROGram[:SELEcted]:WAIT?
<b>Description</b>	Makes the setting so that the 4294A accepts no commands until the status of the program on the 4294A Instrument BASIC editor becomes STOP or PAUSE from RUN.  If this command is executed as Query, 1 is read out when the program status changes from RUN to STOP or PAUSE.
<b>Query response</b>	{1}<newline><^END>
<b>Corresponding key</b>	No front panel key is available to execute this function.

### Commands starting with :PROGram:EXPLicit

The commands starting with :PROGram:EXPLicit have the same function as those starting with :PROGram[:SELEcted]. The below table shows their relationship.

Commands starting with :PROGram:EXPLicit:	Commands starting with :PROGram[:SELEcted]:
:PROGram:EXPLicit:DEFine "PROG"	:PROGram[:SELEcted]:DEFine
:PROGram:EXPLicit:DELete "PROG"	:PROGram[:SELEcted]:DELete:[SELEcted]
:PROGram:EXPLicit:EXECute "PROG"	:PROGram[:SELEcted]:EXECute
:PROGram:EXPLicit:MALLocate "PROG"	:PROGram[:SELEcted]:MALLocate
:PROGram:EXPLicit:NAME "PROG"	:PROGram[:SELEcted]:NAME
:PROGram:EXPLicit:NUMBer "PROG"	:PROGram[:SELEcted]:NUMBer
:PROGram:EXPLicit:STATe "PROG"	:PROGram[:SELEcted]:STATe
:PROGram:EXPLicit:STRing "PROG"	:PROGram[:SELEcted]:STRing
:PROGram:EXPLicit:WAIT "PROG"	:PROGram[:SELEcted]:WAIT

If you change the definition of the program name with the “:PROGram[:SELEcted]:NAME” command on page 453, the “PROG” part in the table must be replaced with the program name.



---

# A **Manual Changes**

This appendix contains the information required to adapt this manual to earlier versions or configurations of the Agilent 4294A than the current printing date of this manual. The information in this manual applies directly to a 4294A model that has a serial number prefix listed on the title page of this manual.

---

## Manual Changes

To adapt this manual to your Agilent 4294A, refer to Table A-1 and Table A-2.

**Table A-1**      **Manual Changes by Serial Number**

Serial Prefix or Number	Make Manual Changes

**Table A-2**      **Manual Changes by Firmware Version**

Version	Make Manual Changes
Rev 1.10	“Change 1” on page 459

Agilent Technologies uses a two-part, ten-character serial number that is stamped on the serial number plate (see Figure A-1). The first five characters are the serial prefix and the last five digits are the suffix.

Execute the “\*IDN?” command on page 251 to check the firmware version.

**Figure A-1**      **Example of Serial Number Plate**

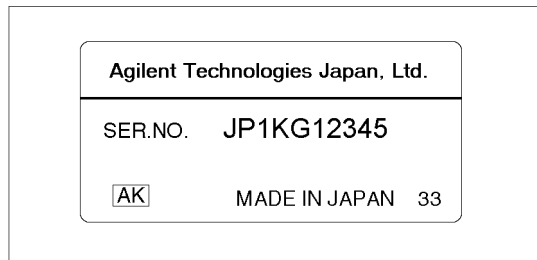

4287a0j048

---

## Change 1

The firmware revision 1.0x does not support the following function.

- Saving an internal data array in the touchstone format.
- SCPI Command “MANR” on page 335

### Change to the revision 1.0x

#### Chapter 6 , “Reading/Writing Measurement Data,” on page 77

Delete the following sentence in “Saving array as file” on page 83

---

#### NOTE

You can save an internal data array in the touchstone format by “SAVDS1P” on page 405. But you cannot recall the file.

#### Chapter 8 , “Saving/Recalling a Measurement Result/Measurement Setup,” on page 111

Delete the following sentence in “Saving data into a file” on page 112

The following command available for save a data array to a file in the touchstone format.

- “SAVDS1P” on page 405

#### Chapter 13 , “Application Sample Programs,” on page 185

Delete the following section

- “Measurement using scanner” on page 229

#### Chapter 16 , “GPIB Command Reference,” on page 247

Delete the following commands.

- “MANR”(335page)
- “SAVDS1P”(405page)

Manual Changes  
**Change 1**



---

## **B**      **Status Reporting System**

This appendix describes the status reporting system of the Agilent 4294A.

## General Status Register Model

The Agilent 4294A has a status reporting system to report the condition of the instrument.

Figure B-1

General Status Register Model

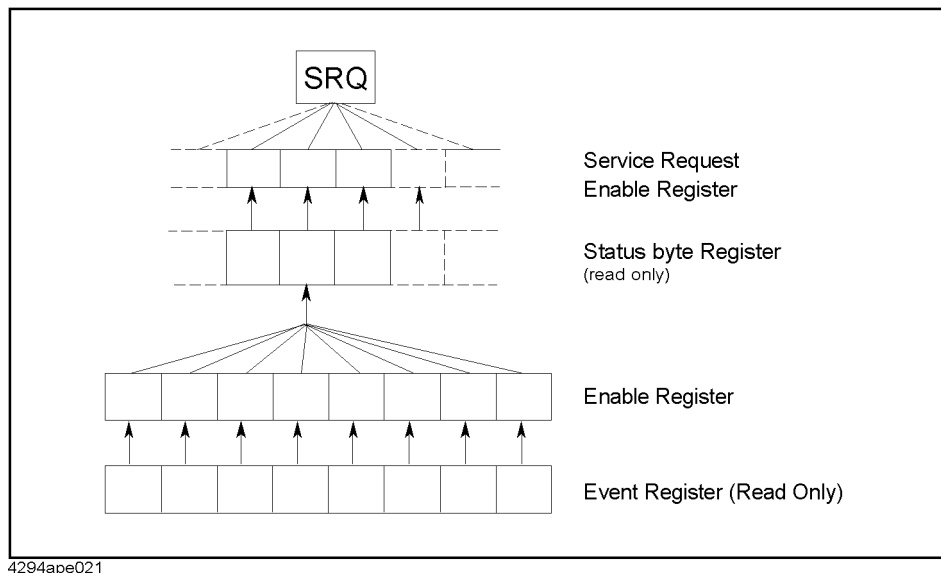

The status reporting system has a hierarchical structure as shown in Figure B-1. When the instrument condition satisfies the particular condition, the corresponding bit of the event register is set “1”. Therefore, you can check the instrument condition by reading the event register.

When the event register bit is set to “1” and a corresponding enable register bit (a bit marked with an arrow in Figure B-1) is also “1”, the summary bit of the status byte register is set to “1”. You can read the status byte register by using the serial poll.

If the bit of the service request enable register is “1”, service request (SRQ) is generated with the positive transition of the corresponding status byte register bit. By generating SRQ, you can notify the controller that the 4294A is requesting service. This implies that interruption by SRQ can be programmed. For more information on using SRQ, see “Using the status register” on page 74 in Chapter 5, “Starting a Measurement (Trigger) and Detecting the Completion of a Measurement (End of Sweeps),” or “Using the Status Register” on page 132 in Chapter 10, “Handling Errors.”

## Event register

Reflects the correspondent condition of the 4294A (e.g. occurrence of an event) as a bit status. These bits monitor the changing 4294A's state continuously and change bit status when the condition (e.g. change bit status to "1" if a specific event occurs) for each bit is met. You cannot change bit status by GPIB command.

4294A has the following event registers:

- Instrument Event Status Register (See Table B-3 for details)
- Standard Event Status Register (See Table B-2 for details)
- Operation Status Event Register (See Table B-4 for details)

## Enable register

Setting the enable register allows you to specify event register bits which can set "1" to the summary bit of the status byte register when an event occurs. The register bits work like mask bits; setting "1" to an enable register will enable a corresponding bit in the event register.

For example, when you want to set "1" the summary bit in the status byte register by a specific register condition, set the corresponding enable register to "1".

## Status byte register

If the enabled event register is set to "1", a corresponding bit of the status byte register is also set to "1". This register also indicates the output queue and SRQ status.

The value of the status byte register can be read by using the `"*STB?"` command on page 253 or serial poll (SPOLL statement in HP BASIC) from the controller. The `"*STB?"` sets the analyzer to remote mode. On the other hand, the SPOLL statement in HP BASIC reads the status byte register value directly without the instrument being set to remote. Therefore, you can continue to operate front panel keys while a controller is reading the status byte register.

Reading the status byte register by the `"*STB?"` command does not affect the contents of the status byte register. However, reading with the SPOLL statement of HP BASIC will clear the RQS bit in the status byte register.

Table B-1 shows the contents of the status byte register for the 4294A. A serial poll initiated by using the SPOLL command reads bit 6 of the status byte register as the RQS bit. The `"*STB?"` command reads bit 6 as the MSS bit. See Table B-1 for details on RQS and MSS bits.

SRQ (Service Request) can be generated linking with the status byte register by setting the service request enable register.

### Transition filter and condition register

The transition filter allows you to select which transitions of the condition of the 4294A will set a bit in the event register.

When the status register has a transition filter, there is a lower register called a condition register under the event register. The transition filter is between the event register and the condition register. The transition filter enables you to select a positive and/or negative transition of the condition register bit to set a bit in the corresponding event register. For example, if you set the negative transition filter, a “1” is set in the event register by changing from “1” to “0” in the condition register.

Figure B-2

Transition Filter and Condition Register

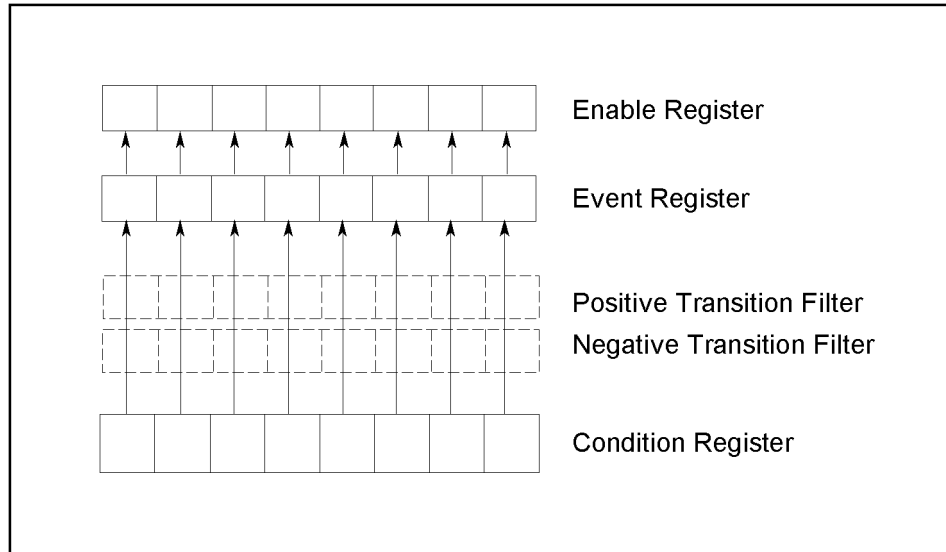

4294ape022

For the 4294A, only the “Program Running” and “Printing” bits of the operation status register has a transition filter (See Figure B-3). By using the transition filter, you can generate an SRQ at the start and/or the end of the program execution.

### Status Register Structure

The status reporting system has a hierarchical structure as shown in Figure B-3. The status byte register is a summary of registers in its lower level. This section describes status registers in each hierarchy. Each bit of the status register is described in Table B-1 through Table B-4.

Figure B-3 Status Register Structure

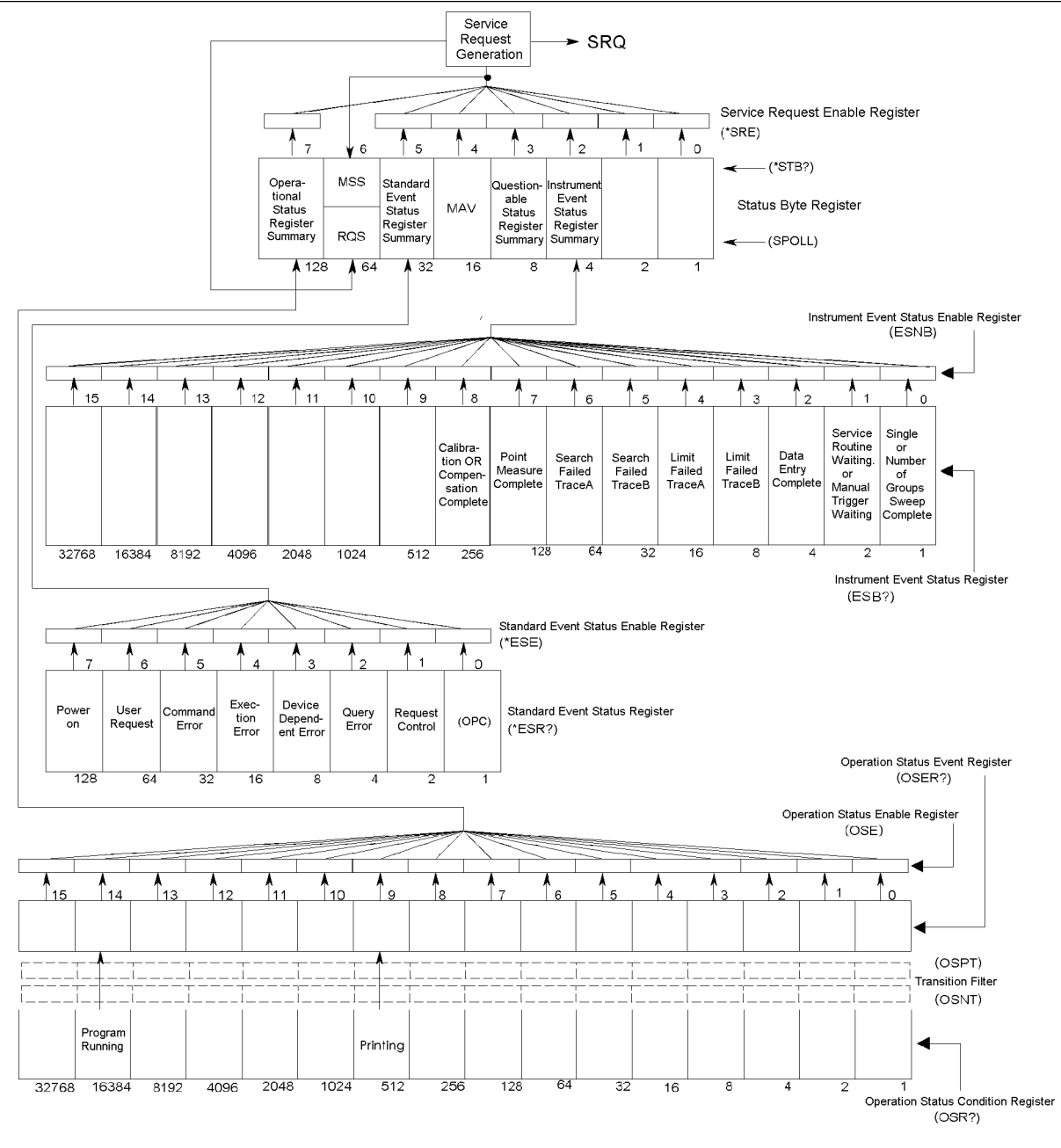

4294ape019

**Table B-1**      **Status Bit Definitions of the Status Byte (STB)**

Bit	Name	Description
2	Instrument Event Status Register Summary Bit	“1” is set when any of the enabled bits in the instrument event status register is set to “1.”
3	Questionable Status Register Summary Bit	The event reporting system of the 4294A reports no event to the questionable status register. This register is provided to assure compatibility with other SCPI instruments.
4	MAV (Message Available)	“1” is set when Output Queue has data and “0” is set when Output Queue has no data.
5	Standard Event Status Register Summary Bit	Set to “1” when any of the enabled bits in the status event status register is set to “1.”
6	RQS (when reading the status byte register through the serial poll.)	“1” is set when an SRQ is generated by the 4294A. “0” is set when the status byte register is read through the serial poll.
	MSS (when reading the status byte register using “*STB?” on page 253.)	“1” is set when any of bits enabled by the service request enable register in the status byte register of the 4294A is set to “1.”
7	Operation Status Register Summary Bit	“1” is set when any of the enabled bits in the operational status register is set to “1.”

Executing “\*CLS” command on page 250 will clear all bits of the status byte register.

Table B-2

Status Bit Definitions of the Event Status Register (ESR)

Bit	Name	Description
0	Operation Complete	“1” is set when all the operations of the overlap command sent before sending “*OPC” command on page 251.
1	Request Control	“1” is set when the 4294A requests GPIB control to continuously operate for controlling its peripheral devices.
2	Query Error	<ol style="list-style-type: none"> <li>1. “1” is set when the 4294A receives a query request, but there is nothing in the output queue to transmit.</li> <li>2. “1” is set when data in the output queue is lost.</li> </ol>
3	Device Dependent Error	“1” is set when an error, other than a command error, a query error, and an execution error occurs.
4	Execution Error	<ol style="list-style-type: none"> <li>1. “1” is set when any parameter in an GPIB command exceeds its input range, or is inconsistent with the 4294A capabilities.</li> <li>2. “1” is set when an GPIB command could not be properly executed due to some condition of the 4294A.</li> </ol>
5	Command Error	<ol style="list-style-type: none"> <li>1. “1” is set when an IEEE 488.2 syntax error has been occurred (a command sent to the 4294A does not follow the IEEE 488.2 syntax). Possible violations include, the command parameter violates the 4294A listening formats or is unacceptable to the 4294A.</li> <li>2. “1” is set when a semantic error occurs. Possible causes include, a command which contains misspelling was sent to the 4294A, or an IEEE 488.2 command that was not supported by the 4294A was sent.</li> <li>3. “1” is set when GET (Group Execution Trigger) is inputted to the program input buffer.</li> </ol>
6	User Request	“1” is set when an operator presses a front panel key, a key on the keyboard connected to the 4294A, or turns the rotary knob.
7	Power ON	“1” is set when the 4294A is powered ON.

Executing “\*CLS” command on page 250 will clear all bits of the standard event status register.

**Table B-3** **Status Bit Definitions of the Instrument Status Register**

Bit	Name	Description
0	Single or Number of Groups Sweep Complete	“1” is set when a single or group sweep was completed after the last read of the register.
1	Service Routine Waiting or Manual Trigger Waiting	<ol style="list-style-type: none"> <li>“1” is set when execution of an internal service routine is completed or when the routine is put into waiting state for operator’s response.</li> <li>“1” is set when the 4294A is put into the manual trigger mode or GPIB/LAN trigger mode and is waiting for a manual trigger.</li> </ol>
2	Data Entry Complete	“1” is set when the terminator key is pressed.
3	Limit Failed, Trace B	“1” is set when a limit test failed on trace B.
4	Limit Failed, Trace A	“1” is set when a limit test failed on trace A.
5	Search Failed, Trace B	“1” is set when no value was obtained for a target of marker search on trace B.
6	Search Failed, Trace A	“1” is set when no value was obtained for a target of marker search on trace A.
7	Point Measurement Complete*1	“1” is set when a measurement of a single point is completed in sweep measurement. (when using the point trigger)
8	Calibration or Compensation Complete	“1” is set when each measurement data is completely obtained for the adapter setting, user calibration, and fixture compensation.

\*1. This bit is set only when both of bits associated with the service request enable register and the instrument event status enable register are enabled.

Executing “\*CLS” command on page 250 will clear all bits of the instrument status register.

**Table B-4** **Status Bit Definitions of the Operation Status Condition Register**

Bit	Name	Description
9	Printing	“1” is set while data is being transferred to the printer.
14	Program Running	“1” is set while an HP Instrument BASIC program is running.

Executing “\*CLS” command will clear all bits of the operation status condition register.



---

## C GPIB command table

This appendix provides the Agilent 4294A GPIB command list sorted according to function.

## GPIB command list sorted according to function

Function	Setting/Operation		GPIB command		
Measurement condition	Preset		“*RST” on page 252 “PRES” on page 393		
	Active trace		“TRAC” on page 444		
	Measurement parameter		“MEAS” on page 337		
	Number of points		“POIN” on page 390		
	Sweep	Parameter		“SWPP” on page 436	
		Type		“SWPT” on page 436	
		Direction		“SWED” on page 435	
		Time		“SWET” on page 435	
		Delay time	Sweep		“SDELT” on page 413
			Measurement point		“PDELT” on page 386
		Range	Start value		“STAR” on page 431
			Stop value		“STOP” on page 433
			Center value		“CENT” on page 269
			Span		“SPAN” on page 429
		Manual sweep	On/Off		“MANS” on page 336
			Point setting		“MANP” on page 334
	Range setting		“MANR” on page 335		
	OSC	Level	setting mode	“POWMOD” on page 393	
			setting	“POWE” on page 392	
		Frequency		“CWFREQ” on page 276	
	DC bias	On/Off		“DCO” on page 282	
		Range		“DCRNG” on page 284	
		Mode		“DCMOD” on page 281	
		Level	Current		“DCI” on page 281
			Voltage		“DCV” on page 285
			Maximum voltage		“MAXDCV” on page 336
	Minimum voltage		“MINDCV” on page 339		
Bandwidth		“BWFACT” on page 266			
Averaging	Sweep	On/Off	“AVER” on page 261		
		Factor	“AVERFACT” on page 261		
		Restart	“AVERREST” on page 261		
	Measurement point	On/Off	“PAVER” on page 385		
		Factor	“PAVERFACT” on page 385		
List sweep	Span display type (Single/Segment)		“LISPAN” on page 330		
	List	Edit	“EDITLIST” on page 300		
		Clear	“CLEL” on page 271		
		Done	“EDITDONE” on page 300		

Function	Setting/Operation			GPIB command		
List sweep	Segment	Edit		“SEDI” on page 421		
		Add		“SADD” on page 402		
		Determine target segment		“SEGM” on page 422		
		Delete		“SDEL” on page 412		
		Done		“SDON” on page 413		
		Parameter setting	Sweep range	Start value		“STAR” on page 431
				Stop value		“STOP” on page 433
				Center value		“CENT” on page 269
		Span		“SPAN” on page 429		
		Number of points		“POIN” on page 390		
		OSC Level	Setting mode		“POWMOD” on page 393	
			Setting		“POWE” on page 392	
		DC bias	Mode		“DCMOD” on page 281	
			Level	Current	“DCI” on page 281	
				Voltage	“DCV” on page 285	
		Bandwidth		“BWFACT” on page 266		
Point averaging factor		“PAVERFACT” on page 385				
Trace color		“SCOL” on page 411				
Display	On/Off		“SCRN” on page 411			
	Backlight On/Off		“BLIGHT” on page 264			
	Trace A/B split display On/Off		“SPLD” on page 430			
	Displayed trace setting		“DISP” on page 291			
	Copy measurement data to memory		“DATMEM” on page 277			
	Accumulate display On/Off		“ACCUD” on page 255			
	Non-active trace display On/Off		“HIDI” on page 307			
	Allocation (Measurement/IBASIC) setting		“DISA” on page 288			
	Level monitor display setting	OSC		“OMON” on page 354		
		DC bias		“BMON” on page 264		
	Title setting		“TITL” on page 441			
	Offset value setting		“DATOVAL” on page 277			
	Format setting		“FMT” on page 305			
	Phase unit setting		“PHAU” on page 387			
	Expanded phase display On/Off		“EXPP” on page 304			
	Scale	Auto-scaling		“AUTO” on page 260		
		Grid (Linear/Log Y-axis format)	Minimum value		“BOTV” on page 265	
			Maximum value		“TOPV” on page 443	
			reference value	location	“REFP” on page 396	
				value	“REFV” on page 397	
		Scale/div.		“SCAL” on page 410		
		Grid (Complex plane format)	X-axis reference value		“REFX” on page 398	
			Y-axis reference value		“REFY” on page 398	
			Scale/div		“SCAL” on page 410	
		Full scale value (Polar chart format)		“REFV” on page 397		
	Scaled trace (Data/Memory)	Coupled scale On/Off		“SCAC” on page 409		
Trace selection		“SCAF” on page 409				

GPIB command table  
GPIB command list sorted according to function

Function	Setting/Operation			GPIB command		
Limit test	On/Off			“LIMITEST” on page 317		
	Beep On/Off			“BEEFAIL” on page 263		
	Limit line table	Edit		“EDITLIML” on page 300		
		Clear		“LIMCLEL” on page 313		
		Done		“LIMEDONE” on page 315		
	Segment	Edit		“LIMSEDI” on page 321		
		Add		“LIMSADD” on page 319		
		Determine target segment		“LIMSEGM” on page 322		
		Delete		“LIMSDEL” on page 320		
		Quit		“LIMSQUI” on page 322		
		Done		“LIMSDON” on page 320		
		Parameter Setting	Start value		“LIMSTAR” on page 323	
			Stop value		“LIMSTOP” on page 325	
			Limit	Start	Upper value	“LIMUSTAR” on page 326
					Lower value	“LIMLSTAR” on page 317
					Middle value	“LIMVSTAR” on page 328
					Delta	“LIMDSTAR” on page 314
			Stop	Stop	Upper value	“LIMUSTOP” on page 327
					Lower value	“LIMLSTOP” on page 318
	Middle value				“LIMVSTOP” on page 329	
	Delta				“LIMDSTOP” on page 315	
	On/Off		“LIMSTEST” on page 324			
	Limit range offset	Limit value (X-axis) offset		“LIMIAMPO” on page 316		
Sweep parameter value (Y-axis) offset		“LIMIPRMO” on page 316				
Test result output	All measurement points		“OUTPLIML?” on page 372			
	Marker position		“OUTPLIMM?” on page 373			
	Failed measurement point		“OUTPLIMF?” on page 372			
	Number of failed measurement point		“OUTPFAIP?” on page 369			
Adapter setting	Adapter selection			“E4TP” on page 299		
	Data for setup data calculation	Measurement		“ECAL{P A B C}” on page 299		
		Calculate and store to EEPROM		“ECALDON” on page 299		
		Measurement cancel		“ECALQUI” on page 300		
User calibration	Standard for data measurement	Definition	Open	“DCALOPEN{G C}” on page 279		
			Short	“DCALSHOR{R L}” on page 280		
			Load	“DCALLOAD{R L}” on page 278		
		Display Defined value		“CAL\$” on page 267		
	On/Off			“CALST” on page 268		
	Data measurement point setting (User/Fixed)			“CALP” on page 267		
	Data for calibration coefficient calculation	Measurement		“CAL{A B C}” on page 266		
		Calculate and store to RAM		“CALDON” on page 266		
Measurement cancel		“CALQUI” on page 267				
Input data		“INPUCALC{1-3}” on page 309				
Output data		“OUTPCALC{1-3}?” on page 362				
Port extension compensation	On/Off			“PORE” on page 390		
	Port extension value	Delay time		“PORTZ” on page 391		
		Electrical length		“PORTL” on page 391		

GPIB command table  
GPIB command list sorted according to function

Function	Setting/Operation			GPIB command		
Fixture compensation	Standard for data measurement	Definition	Open	“DCOMOPEN{G C}” on page 283		
			Short	“DCOMSHOR{R L}” on page 284		
			Load	“DCOMLOAD{R L}” on page 282		
		Display Defined value			“COMS” on page 273	
	On/Off			“COMST{A B C}” on page 274		
	Data measurement point setting (User/Fixed)			“CALP” on page 267		
	Data for compensation coefficient calculation		Measurement	“COM{A B C}” on page 273		
Input data			“INPUCOMC{1-3}” on page 310			
Output data			“OUTPCOMC{1-3}?” on page 363			
Measurement	Sweep	Mode setting	Continuous	“CONT” on page 274		
			Hold	“HOLD” on page 307		
		Operation	Single	“SING” on page 424		
			Specified number	“NUMG” on page 353		
	Trigger	Source selection		“TRGS” on page 446		
		Polarity of external trigger signal		“TRGP” on page 445		
		Trigger event mode		“TRGEVE” on page 445		
		GPIB/LAN triggering		“*TRG” on page 253		
Data read/write	Data transfer format selection		ASCII format	“FORM4” on page 306		
			IEEE 32-bit floating point format	“FORM2” on page 306		
			IEEE 64-bit floating point format	“FORM3” on page 306		
			MS-DOS personal computer format	“FORM5” on page 306		
	Read	Data array		All measurement points	“OUTPDATA?” on page 364	
				Specified measurement point	“OUTPDATAP?” on page 364	
		Memory array		All measurement points	“OUTPMEMO?” on page 374	
				Specified measurement point	“OUTPMEMOP?” on page 374	
		Data trace array		All measurement points	“OUTPDTRC?” on page 367	
				Specified measurement point	“OUTPDTRCP?” on page 368	
		Memory trace array		All measurement points	“OUTPMTRC?” on page 377	
				Specified measurement point	“OUTPMTRCP?” on page 378	
		User calibration data array			“OUTPCALC{1-3}?” on page 362	
		Fixture compensation data array			“OUTPCOMC{1-3}?” on page 363	
		Sweep parameter array		All measurement points	“OUTPSWPRM?” on page 383	
				Specified measurement point	“OUTPSWPRMP?” on page 383	
		level monitor result	OSC	Voltage	All measurement points	“OUTPVAC?” on page 383
					Specified measurement point	“OUTPVACP?” on page 384
				Current	All measurement points	“OUTPIAC?” on page 369
					Specified measurement point	“OUTPIACP?” on page 370
	DC bias		All measurement points	“OUTPDC?” on page 365		
	Specified measurement point		“OUTPDCP?” on page 365			
	Limit test result	All measurement points		“OUTPLIML?” on page 372		
		Marker position		“OUTPLIMM?” on page 373		
		Failed measurement points		“OUTPLIMF?” on page 372		
		Number of failed measurement points		“OUTPFAIP?” on page 369		
	Occurred error information (Error queue)			“OUTPERRO?” on page 369		

GPIB command table  
GPIB command list sorted according to function

Function	Setting/Operation		GPIB command		
Data read/write	Write	Data array	“INPUDATA” on page 310		
		Data trace array	“INPUDTRC” on page 311		
		User calibration data array	“INPUCALC{1-3}” on page 309		
		Fixture compensation data array	“INPUCOMC{1-3}” on page 310		
Marker	Marker movement setting	Movement mode (Continuous/Discrete)	“MKRMOV” on page 344		
		Trace A/B coupled mode On/Off	“MKRCOUP” on page 341		
	Objective trace selection (Data/Memory)		“MKRO” on page 345		
	Marker (Main marker)	On/Off		“MKR” on page 339	
		Read marker value	Measurement parameter value	“MKRVAL?” on page 349	
			Secondary measurement parameter value	“MKRAUV?” on page 340	
			Sweep parameter value	“MKRPRM” on page 347	
			Measurement/Sweep parameter value	“OUTPMKR?” on page 376	
		Move	Specified measurement point	“MKRP” on page 346	
	Specified sweep parameter value		“MKRPRM” on page 347		
	Sub marker	On/Off		“SMKR{1-7}” on page 425	
		Read marker value	Measurement parameter value	“SMKRVAL{1-7}?” on page 428	
			Secondary measurement parameter value	“SMKRAUV{1-7}?” on page 425	
			Sweep parameter value	“SMKRPRM{1-7}” on page 427	
			Measurement/Sweep parameter value	“OUTPSMKR{1-7}?” on page 382	
		Move	Specified measurement point	“SMKRP{1-7}” on page 426	
	Specified sweep parameter value		“SMKRPRM{1-7}” on page 427		
	Δ marker	Mode setting		“DMKR” on page 292	
		Read marker value	Measurement parameter value	“DMKRVAL” on page 296	
			Secondary measurement parameter value	“DMKRAUV” on page 293	
			Sweep parameter value	“DMKRPRM” on page 295	
			Measurement/Sweep parameter value	“OUTPDMKR?” on page 366	
		Move	Specified measurement point		“DMKRP” on page 294
			Fixed Δ marker only	Specified measurement parameter value	“DMKRVAL” on page 296
				Specified secondary measurement parameter value	“DMKRAUV” on page 293
			Specified sweep parameter value		“DMKRPRM” on page 295
			Unit of sweep parameter value		“MKRXUNIT” on page 350
	Level monitor value display mode setting		“MKRMON” on page 344		
	Marker list function On/Off		“MKRL” on page 341		
	Marker sweep parameter value	→ Sweep start value		“MKRSTAR” on page 348	
		→ Sweep stop value		“MKRSTOP” on page 348	
		→ Sweep center value	Set	“MKRCENT” on page 340	
			Set and zoom span	“MKRZM” on page 350	
Zooming aperture setting			“ZMAPER” on page 450		
→ Measurement point of manual sweep		“MKRMANP” on page 343			
→ Start point of limit range		“MKRLIMSTAR” on page 342			
→ Stop point of limit range		“MKRLIMSTOP” on page 342			
Difference of sweep parameter between marker and Δ marker → Span		“MKRDSPAN” on page 341			
Marker measurement parameter value	→ Grid reference value		“MKRREF” on page 347		
	→ X-axis offset value of limit range		“MKRAMPO” on page 340		
	→ Start point middle value of limit range		“MKRLIMVSTAR” on page 343		
	→ Stop point middle value of limit range		“MKRLIMVSTOP” on page 343		

Function	Setting/Operation		GPIB command		
Marker search	Search range setting	Partial search On/Off		“PARS” on page 384	
		Upper limit	Specified measurement point	“SEARMAXP” on page 417	
			Specified sweep parameter value	“SEARMAX” on page 416	
			Marker position	“MKRTRMAX” on page 348	
		Lower limit	Specified measurement point	“SEARMINP” on page 419	
			Specified sweep parameter value	“SEARMIN” on page 418	
			Marker position	“MKRTRMIN” on page 349	
	Range between marker and $\Delta$ marker		“MKRTR” on page 348		
	Search range setting for List sweep	Search range (All segments/Specified segment)		“SEARNG” on page 419	
		Search segment		“SEGNUM” on page 423	
		Search range line display On/Off		“SEARLINE” on page 415	
	Search tracking function On/Off			“TRACK” on page 444	
	Peak definition	$\Delta X$ value setting		“PKDLTX” on page 388	
		$\Delta Y$ value setting		“PKDLTY” on page 389	
		Polarity setting		“PKPOL” on page 389	
		Automatic definition using marker		“MKRPKD” on page 346	
	Search (Maximum value/Minimum value/Peak/Target value)			“SEAM” on page 414	
	Peak search	Next peak search		“SEANPK” on page 414	
		Left Peak search		“SEANPKL” on page 414	
		Right Peak search		“SEANPKR” on page 415	
Peak value $\rightarrow$ sweep center value		“PEAKCENT” on page 387			
Target search	Target value setting		“SEATARG” on page 420		
	Target line display On/Off		“SEATARGL” on page 420		
	Left target search		“SEAL” on page 413		
	Right target search		“SEAR” on page 415		
Analysis	Equivalent circuit analysis	Equivalent circuit model	Selection	“EQUC” on page 301	
			Display On/Off	“DISECIRC” on page 288	
		Equivalent circuit parameter calculation			“CALECPARA” on page 267
		Equivalent circuit parameter	Display On/Off	“DISECPARA” on page 289	
			Read/Definition	“DEFEC {R1 C1 L1 C0}” on page 286	
	Frequency response simulation			“SIMFCHAR” on page 424	
	Statistical analysis	On/Off		“MEASTAT” on page 338	
		Read analysis result		“OUTPMSTA?” on page 377	
	Trace bandwidth analysis	On/Off		“WIDT” on page 448	
		Cutoff point definition	definition type	“WIDVTYPE” on page 449	
			Fixed value setting	“WIDFVAL” on page 447	
		Read analysis result		“OUTPMWID?” on page 379	
		Inside cutoff point search		“WIDSIN” on page 447	
Outside cutoff point search		“WIDSOUT” on page 448			

**GPiB command table**  
**GPiB command list sorted according to function**

Function	Setting/Operation			GPiB command	
Analysis	Waveform analysis	Condition	Range setting	Specified range	“ANARANG” on page 259
				Sweep range	“ANARFULL” on page 260
			Segment selection	“ANASEGM” on page 260	
			Trace selection	Data trace	“ANAODATA” on page 258
				Memory trace	“ANAOMEMO” on page 258
		Peak definition	“THRR” on page 439		
		Analysis commands	Maximum value search	“OUTPMAX?” on page 373	
			Minimum value search	“OUTPMIN?” on page 375	
			Maximum and minimum values search	“OUTPMINMAX?” on page 375	
			Maximum positive peak search	“PEAK?” on page 386	
			Next maximum positive peak search	“NEXPK?” on page 352	
			Minimum negative peak search	“NPEAK?” on page 353	
			Next minimum negative peak search	“NEXNPK?” on page 351	
			n <sup>th</sup> positive peak search	“LMAXS?” on page 332	
			n <sup>th</sup> negative peak search	“LMINS?” on page 333	
			Specified measurement parameter value search	To right	“TARR?” on page 438
				To left	“TARL?” on page 437
			Analysis of maximum difference between positive and negative peaks	value	“RPLPP?” on page 400
				value and peak position	“RPLPPS?” on page 401
			Analysis of maximum difference between positive peak and its adjacent negative peak	Both sides	“RPLHEI?” on page 400
				Left side	“RPLLHEI?” on page 400
		Right side		“RPLRHEI?” on page 401	
		Resonator analysis	0-phase point		“OUTPRESO?” on page 380
			0-phase point and ripple		“OUTPRESR?” on page 381
			Ceramic resonator parameter		“OUTPCERR?” on page 362
			Equivalent circuit parameter of crystal resonator		“EQUCPARS4?” on page 302
			parallel capacitance		“EQUC0?” on page 301
Save, recall and so on	Save	State (meas. condition, memory/user cal. data/fixture compen. data array)		“SAVDSTA” on page 406	
		Screen graphics		“SAVDTIF” on page 406	
		Internal data arrays	Save	ASCII file	“SAVDASC” on page 403
				Binary file	“SAVDDAT” on page 404
				Touchstone file (Data array only)	“SAVDS1P” on page 405
		Select	Data array	“SAVDAT” on page 404	
			Memory array	“SAVMEM” on page 407	
			Data trace array	“SAVDTRC” on page 407	
			Memory trace array	“SAVMTRC” on page 408	
			User cal. data / fixture compen. data array	“SAVCAL” on page 403	
		Update			“RESAVD” on page 399
		Save state as AUTOREC.STA			“SAVPSTA” on page 408
		Recall			“RECD” on page 395
		Storage device selection			“STOD” on page 432
		Directory	Create		“CRED” on page 276
			Move		“CHAD” on page 270
		File	Copy		“FILC” on page 305
			Delete		“PURG” on page 395
		Disk formatting			“INID” on page 308



GPIB command table  
GPIB command list sorted according to function

Function	Setting/Operation	GPIB command		
Status report structure	Clear registers	“*CLS” on page 250 “CLES” on page 271		
	Set service request enable register	“*SRE” on page 252		
	Read status byte register	“*STB?” on page 253		
	Set standard event status enable register	“*ESE” on page 250		
	Read standard event status register	“*ESR?” on page 251		
	Set instrument event status enable register	“ESNB” on page 304		
	Read instrument event status register	“ESB?” on page 303		
	Set operation status enable register	“OSE” on page 354		
	Set positive transition filter of operation status register	“OSPT” on page 356		
	Set negative transition filter of operation status register	“OSNT” on page 355		
	Read operation status event register	“OSER?” on page 355		
	Read operation status condition register	“OSR?” on page 356		
	LAN	4294A IP address setting	“ADDRIP” on page 257	
Gateway IP address setting		“ADDRGW” on page 256		
Subnet mask		“SUBNET” on page 434		
Printer	Displayed item selection	Trace (Normal display)	“RESD” on page 399	
		list of sweep parameter and measurement parameter values	Display	“LISV” on page 330
			Display next page	“NEXP” on page 352
			Display previous page	“PREP” on page 393
		list of measurement condition parameters	“OPEP” on page 354	
		list of standard definitions for user calibration	“CALS” on page 267	
		list of standard definitions for fixture compensation	“COMS” on page 273	
		List sweep table	Display	“DISL” on page 289
			table format selection	“DISMPRM” on page 290
		Limit line table	Display	“DISLLIST” on page 289
	table format selection		“DISMAMP” on page 290	
	Printing	Print	“PRINALL” on page 394	
		Cancel	“COPA” on page 274	
		Setting	Reset	“DFLT” on page 287
			Resolution	“DPI” on page 298
			Formfeed On/Off	“FORMFEED” on page 307
			Direction	“LANDSCAPE” on page 313
			Left margin	“LMARG” on page 331
			Top margin	“TMARG” on page 442
			Softkey label printing On/Off	“PRSOFT” on page 394
Time stamp function On/Off			“COPT” on page 275	
Color	“PRIC” on page 394			
LCD	Screen	Intensity	“INTE” on page 311	
		Background intensity	“BACI” on page 262	
	Display element	Element selection	“COLO” on page 272	
		Brightness	“CBRI” on page 268	
		Chroma	“COLOR” on page 273	
		Hue	“TINT” on page 441	
	Reset	All settings	“DEFC” on page 285	
		Specified	“RSCO” on page 401	

GPIB command table  
GPIB command list sorted according to function

Function	Setting/Operation		GPIB command		
I/O port	8 bit I/O port	Data output	“OUT8IO” on page 357		
		Data input	“INP8IO?” on page 308		
	24 bit I/O port	Data output	Port A	“OUTAIO” on page 358	
			Port B	“OUTBIO” on page 358	
			Port C	“OUTCIO” on page 359	
			Port D	“OUTDIO” on page 359	
			Port E	“OUTEIO” on page 360	
			Port F	“OUTFIO” on page 360	
			Port G	“OUTGIO” on page 361	
			Port H	“OUTHIO” on page 361	
		Data input	Port C	“OUTPINPCIO?” on page 370	
			Port D	“OUTPINPDIO?” on page 371	
			Port E	“OUTPINPEIO?” on page 371	
		Port C setting	Set output port	“COUT” on page 275	
			Set input port	“CIN” on page 270	
		Port D setting	Set output port	“DOUT” on page 297	
			Set input port	“DIN” on page 287	
		Check INPUT1 pulse input			“INPT?” on page 308
		OUTPUT1 setting	High level / Low level	“OUT1 {H L}” on page 356	
			Operation when INPUT1 detects pulse input	“OUT1ENV {H L}” on page 356	
OUTPUT2 setting	High level / Low level	“OUT2 {H L}” on page 357			
	Operation when INPUT1 detects pulse input	“OUT2ENV {H L}” on page 357			
Positive / Negative logic selection	Positive logic	“POSL” on page 392			
	Negative logic	“NEGL” on page 351			
Beep	On/Off setting of the beep to notify the completion of operation		“BEEPDONE” on page 262		
	On/Off setting of the beep when the limit test result is FAIL		“BEEPFAIL” on page 263		
	On/Off setting of the beep when an error occurred or when an invalid key is pressed		“BEEPWARN” on page 263		
Clock	Date display format setting		“DMODE” on page 297		
	Date setting		“SETCDATE” on page 423		
	Time setting		“SETCTIME” on page 424		
Key	Disable front panel key and rotary knob		“DSKEY” on page 298		
	Enable front panel key and rotary knob		“ENKEY” on page 300		
	Send key code		“KEY” on page 312		
	Show ON KEY LABELS		“USKEY” on page 446		
Others	Wait for command operation completion		“*WAI” on page 254		
	Read 1 when operation completes		“*OPC?” on page 251		
	Set 1 to OPC bit when operation completes		“*OPC” on page 251		
	Controller GPIB address setting		“ADDRCONT” on page 255		
	Read product information		“*IDN?” on page 251		
	Read option information		“*OPT?” on page 252		
	Self test operation		“*TST?” on page 253		

---

## **D** Error messages

The Agilent 4294A provides error messages to indicate its operating status. This appendix describes the error messages of the the 4294A.

Error messages are outputted on the 4294A's LCD or through GPIB. This section gives you the description of each error message and its remedy.

---

**NOTE**

If an error with a positive error number occurs, only its error message is displayed on the LCD following the string of "CAUTION:"(in this case, its error number is not displayed). On the other hand, if an error with a negative error number occurs, CAUTION: GPIB error occurred" is always displayed on the LCD. When error messages are outputted through GPIB, their error number and error message are outputted for all errors ("CAUTION:" is not added). Some messages displayed on the LCD do not have "CAUTION:"; these are not error messages. Messages without "CAUTION:" are not described here.

Errors with a negative error number are basically general errors for GPIB instruments defined by IEEE488.2. On the other hand, errors with a positive error number are ones defined specifically for the 4294A.

---

---

## Order of error number

0

### (No error)

No error has occurred.

This message is not displayed on the LCD. 0 is returned as the error number if no error has occurred in the instrument when the OUTPERRO? command is sent through GPIB.

10

### ADDITIONAL STANDARDS NEEDED

Before the measurement of all the calibration standards (OPEN, SHORT, LOAD) required to complete user calibration or four-terminal pair extension setting were completed, an GPIB command (CALDON or ECALDON) to calculate error coefficients was sent. The command was invalid. Measure all the required calibration standards.

11

### CALIBRATION REQUIRED

In user calibration or fixture compensation, though error coefficients based on the measurement of the required calibration standards (OPEN, SHORT, or LOAD) had not been acquired, an GPIB command (CALST ON, COMCA ON, COMCB ON, or COMCC ON) that turned on the user calibration function or fixture compensation function was sent. Valid error coefficients were not detected. The command was invalid. For user calibration, it is required to measure all the calibration standards (OPEN, SHORT, LOAD) and acquire error coefficients based on the measurement. On the other hand, for fixture compensation, it is required to measure a calibration standard (OPEN, SHORT, or LOAD) corresponding to the fixture compensation function (OPEN compensation function, SHORT compensation function, or LOAD compensation function) you want to turn on and obtain error coefficients based on the measurement.

12

### CALIBRATION NOT USABLE

A command to execute data measurement for unnecessary (not allowed) calibration (user calibration or fixture compensation) for the current adapter selection is sent. The command is invalid. For example, when NONE (no adapter) is selected as the adapter selection, sending the CALA command, which executes OPEN data measurement for the user calibration, causes this error (when the adapter selection is NONE, you cannot execute the user calibration).

Execute the measurement of necessary (allowed) calibration data for the current adapter selection. For more information on the appropriate adapter selection and calibration, refer

to “Adapter Setting” on page 54

13

### **CALIBRATION ABORTED**

One of the following occurred.

- In the middle of or after the completion of the setup for user calibration or fixture compensation (measurement of required calibration data and calculation and storage of error coefficients), the setting of calibration points (FIXED or USER) was changed. The current setup and error coefficients previously stored are now invalid.
- When the setting of calibration points was USER, in the middle of or after the completion of the setup for user calibration or fixture compensation (measurement of required calibration data and calculation and storage of error coefficients), the sweep condition (sweep range, sweep parameter, number of sweep points, sweep type) was changed. The current setup and error coefficients previously stored are now invalid.
- In the middle of the setup for user calibration or four-terminal pair extension (measurement of required calibration data and calculation and storage of error coefficients), the setup was canceled (the cancel key, CALQUI command, or ECALQUI command was executed). The setup is invalid. However, error coefficients previously stored are available.

If necessary, perform the setup for user calibration, fixture compensation, or four-terminal pair extension.

17

### **BACKUP DATA LOST**

The contents of the battery-backed memory (SRAM), storing user calibration data, fixture compensation data, GPIB address, IP address, and so on, were lost, causing an error (check sum error). Its cause is running out of the battery for backup. To enable the battery backup for the memory again, turn on the power and keep it approximately 10 minutes to charge the battery completely.

19

### **UNEXPECTED DATA DETECTED**

During the measurement of calibration data (OPEN, SHORT, LOAD) for user calibration, fixture compensation, and four-terminal pair extension setting, abnormal data was detected and the acquisition of the calibration data was aborted. Check to see if there is no problem in standards or setup you use.

26

### **PRINTER: not on, not connected, out of paper**

The printer does not respond to the control from the 4294A. Check the power to the printer, online status, paper, and so on. Or, the connected printer may not be supported. For information on supported printers, refer to the "Options and accessories" chapter.

34

### **MEMORY TRACE NOT ACTIVE**

Though no data was stored in the memory trace, you attempted to execute a command (DISP MEMO, DMNM, and so on) that used the memory trace. The command was invalid. First, use the DATMEM command and store data in the memory trace.

35

### **CAN'T CALCULATE EQUIVALENT PARAMETERS**

Because measurement data does not match with the selected equivalent circuit, equivalent circuit parameters cannot be calculated. Acquire data again or select another equivalent circuit.

36

### **MUST BE MORE THAN 2 POINTS FOR ANALYSIS**

Though the calculation of equivalent circuit parameters (CALCULATE PARAMETERS

## Error messages

### Error number: 37

key, CALC PARMs key, or CALECPARA command) was executed, because the number of points (NOP) within the sweep range (if the partial search function is on, within the specified search range) is 2, they cannot be calculated. Set the number of points within the sweep range (if the partial search function is on, within the specified search range) to 3 or more.

#### 37 **DISPLAY BUFFER IS FULL**

The use of the DRAW or MOVE command of HP Instrument BASIC made 4294A's display buffer full. Further write to the display buffer is impossible.

#### 48 **PHASE LOCK LOOP UNLOCKED**

Anomalies in the 4294A's internal circuit were detected (phase lock loop was not locked). The instrument needs adjustment or repair. Contact your local Agilent Technologies sales office or the company you purchased this instrument from.

#### 54 **TOO MUCH DATA**

When data was sent from the controller to the 4294A in the FORM2, FORM3, or FORM5 data transfer format, the amount of the sent binary data was too large, or data items exceeded the number of points (NOP) set in the 4294A. Set data to be sent or the number of points of the 4294A correctly.

#### 55 **NOT ENOUGH DATA**

When data was sent from the controller to the 4294A in the FORM2, FORM3, or FORM5 data transfer format, the amount of the sent binary data was too small, or data items did not reach the number of points (NOP) set in the 4294A. Set data to be sent or the number of points of the 4294A correctly.

#### 64 **TOO MANY SEGMENTS**

You attempted to add segments whose quantity exceeded the maximum number (18) to the limit line table. The number of segments you can set in the limit line table is up to 18.

#### 74 **CURRENT EDITING SEGMENT SCRATCHED**

During the edit of a segment in the list sweep table or limit line table, a key or command not related to edit of the table was executed, and the segment that was being edited became invalid. To avoid this, press "done key" in the segments menu, SDON (command to finish the edit of a list sweep segment), or LIMSDON (command to finish the edit of a limit segment), and then perform other settings.

#### 75 **COMMAND IGNORED -SEGMENT NOT DONE YET**

During the edit of a segment in the list sweep table or limit line table, an inappropriate edit command (EDIT LIML, EDITLIST, LIMCLEL, LIMSEDI, LIMSADD, LIMSDEL, SLEL, SEDI, SADD, SEGM) was sent and, as a result, the command was ignored. If necessary, execute SDON (command to finish the edit of a list sweep segment), or LIMSDON (command to finish the edit of a limit segment) to finish the edit of the segment, and then perform the setting.

#### 77 **TOO MANY SEGMENTS OR POINTS**

During the edit of the list sweep table, you attempted to set a value that exceeded the maximum of segments (18), the maximum number of points per segment (201), or the maximum number of total points in all segments (801). Set a value of the number of segments or the number of points that does not exceed the maximum value.

#### 82 **CAN'T CHANGE -ANOTHER CONTROLLER ON BUS**

When an active controller was on the same GPIB bus, you attempted to set the 4294A as a system controller. Unless another active controller is removed from the same GPIB bus, you cannot set the 4294A as a system controller.

83

#### **NOT VALID FOR COMPLEX MEASUREMENT**

When the COMPLEX Z-Y measurement parameter (that is, complex parameter measurement) is selected, a command to execute one of the following is sent. As a result, the command is ignored.

- Setting or reading an offset value in the trace calculation function (DATOVAL command)
- Assigning the main marker to the offset value in the trace calculation function (MKROFS command)
- Selecting DELTA % in the trace calculation function (DISP DELP command)

When making the above settings, first select a measurement parameter other than COMPLEX Z-Y.

84

#### **NOT VALID FOR SCALAR MEASUREMENT**

When a measurement parameter other than COMPLEX Z-Y (that is, scalar parameter measurement) is selected, a command to execute one of the following is sent. As a result, the command is ignored.

- Setting the secondary measurement parameter value of the fixed  $\Delta$  marker (DMKRAUV command)
- Selecting DATA/MEM in the trace calculation function (DISP DDVM command)

When making the above settings, first select the COMPLEX Z-Y measurement parameter.

85

#### **FORMAT NOT VALID FOR COMPLEX MEASUREMENT**

When COMPLEX Z-Y (i.e., complex parameter measurement) was selected as a measurement parameter, you attempted to select a display format not available for the measurement parameter, for example, the linear scale format (FMT LINY command) and, as a result, the command was ignored. When COMPLEX Z-Y is selected as a measurement parameter, set the display format to the complex plane display format (command: FMT COMP) or the polar coordinates display format (command: FMT POLA).

86

#### **FORMAT NOT VALID FOR SCALOR MEASUREMENT**

When a measurement parameter other than COMPLEX Z-Y (i.e., scalar parameter measurement) was selected, you attempted to select a display format not available for the measurement parameter, for example, the complex plane display format (command: FMT COMP) and, as a result, the command was ignored. When a measurement parameter other than COMPLEX Z-Y is selected, select a display format from the linear scale format (command: FMT LINY), the log scale format (command: FMT LOGY), or the percent format (command: FMT PERC).

87

#### **THETA MEASUREMENT NOT SELECTED**

When the setting of the phase ( $q$ ) was not active as a measurement parameter, you attempted to execute a command to set the phase unit (PHAU DEG or PHAU RAD) or a command to set the phase expansion display (EXPP ON or EXPP OFF) and, as a result, the command was ignored. The active status of the phase ( $\theta$ ) setting means:

- $|Z|-\theta$  or  $|Y|-\theta$  is selected as a measurement parameter and trace B is active.

## Error messages

### Error number: 88

- COMPLEX Z-Y is selected as a measurement parameter, and the display format is PLOAR (polar coordinates display format) for the selected active trace.

Before executing a command to set the phase unit or a command to set the phase expansion display, perform one of the above settings.

88

#### **MATH FUNCTION NOT VALID FOR PERCENT FORMAT**

When the percent format was selected as the display format, you attempted to change the setting of data operations. In the percent format, data operations are fixed to delta % (command: MATH DELP), and therefore, you cannot change the data operation setting to DATA (command: MATH DATA), DATA-MEM (command: MATH DMNM), or DATA/MEM (command: MATH DDVM).

89

#### **PERCENT FORMAT NOT SELECTED**

When the percent format was not selected as the display format, you attempted to select delta % as the data operation setting (you sent the MATH DELP command). If you want to select delta % as the data operation setting, the percent format (command: FMT PERC) must have been selected as the display format.

90

#### **SCALE PARAMETER NOT VALID**

You attempted to set a display scale not settable for the selected display format and, as a result, the command was ignored. For example, when the log scale (command: FMT LOGY) was selected as the display format, you attempted to perform the SCALE/DIV setting (command: SCAL <value>).

91

#### **DATA AND MEMORY TRACE NOT DISPLAYED**

When both of the data trace and the memory trace were not displayed, you attempted to change the setting of the data & memory couple (command: SCAC ON or SCAC OFF). To change the setting of the data & memory couple, first, display both of the data trace and the memory trace (command: DISP DATM).

93

#### **DATA TRACE NOT DISPLAYED**

When the data trace was not displayed, you attempted to set the function that needed the display of the data trace and, as a result, the command was ignored. For example, a command (MKRO DATA or SCAF DATA) corresponding to the MARKER ON [DATA] key or the SCALE FOR [DATA] key was sent. Before setting the function that needs the display of the data trace, display the data trace (command: DISP DATA or DISP DATM).

94

#### **MEMORY TRACE NOT DISPLAYED**

When the memory trace was not displayed, you attempted to set the function that needed the display of the memory trace and, as a result, the command was ignored. For example, a command (MKRO MEMO or SCAF MEMO) corresponding to the MARKER ON [MEMORY] key display or the SCALE FOR [MEMO] key display was sent. Before setting the function that needs the display of the memory trace, display the memory trace (command: DISP MEMO or DISP DATM).

98

#### **NO ACTIVE MARKER**

When the marker was not displayed, you attempted to execute the marker moving (Marker?) function and, as a result, the command was ignored. For example, when the marker was not displayed, a command corresponding to the MKR?START key (MKRSTAR) was sent. Before executing the marker moving function, display the marker (command: MKR ON).

99

#### **DELTA MARKER OFF**



When the delta marker was not displayed, you attempted to execute a function that needed the display of the delta marker and, as a result, the command was ignored. For example, when the delta marker was not displayed, a command corresponding to the MKRD?SPAN key (MKRDSPAN) was sent. Before executing a function using the delta marker, first display the delta marker (command: DMKR ON).

100 **NO FIXED DELTA MARKER**

When the fixed  $\Delta$  marker (FIXED DMKR) was not displayed, you attempted to execute a command of a function that needed the display of the fixed  $\Delta$  marker and, as a result, the command was ignored. For example, when the fixed  $\Delta$  marker was not displayed, a command corresponding to the FIXED DMKR VALUE, FIXED DMKR AUX VALUEN key (DMKRVAL <value>, DMRRAUV <value>) was sent. Before executing a function using the fixed  $\Delta$  marker, first display the fixed  $\Delta$  marker (command: DMKR FIX).

101 **SEARCH WIDTH OFF**

When the band width function was off, you attempted to execute a command to search the cutoff point on the trace (WIDSIN or WIDSOUT) and, as a result, the command was ignored. Before executing the cutoff point search of the band width function, turn on the band width function (command: WIDT ON).

102 **SEARCH RANGE TYPE IS NOT SEGMENT**

Though, in the list sweep, all segments (entire sweep range) were specified as the search range (command: SEARNG FULL), you attempted to execute a command to specify a certain segment as a search target (SEGMNUM <value>) and, as a result, the command was ignored. Before executing the search function by specifying a certain list sweep segment, set the search range to a single segment (command: SEARNG SEGMENT).

105 **MEASUREMENT PARAMETER NOT FOR ANALYSIS**

When a measurement parameter other than  $|Z|_q$  was set, you attempted to execute a waveform analysis command (for example, OUTPCERR?) and, as a result, the command was ignored. Before executing a waveform analysis command, set the measurement parameter to  $|Z|_0$  (command: MEAS IMPH).

110 **SAVE ERROR**

When saving a file, anomalies in the storage media were detected. For example, if you attempt to save a file on a floppy disk, it may be damaged. Check to see if there is no problem in the storage media.

111 **RECALL ERROR: INSTR STATE PRESET**

Because an error occurred during reading out a file, the 4294A is being preset. This error occurs, for example, when data in a file to be read out is destroyed or when an extension for a file name does not match with the contents of the file.

112 **INVALID FILE NAME**

When the recall command (RECD <string>) or the resave command (RESAVD <string>) was executed, a string that indicated a file name was not followed by a necessary extension and, as a result, the command was ignored. Add a required extension, and then perform recall or resave. This message occurs, for example, when you attempt to execute the recall or resave command without adding an extension (".STA", ".DAT", ".TXT") to a file name. Also, it does when you attempt to execute resave of a graphics file without adding an extension (".TIF").

113 **NO STATE/DATA FILES ON DISK**

Though you attempted to display the list of files and directories on a floppy disk on the softkey label by executing the recall ([Recall]) key, file resave (RE-SAVE FILE) key, file deletion (PURGE FILE) key, directory change (CHANGE DIRECTORY) key, or file copy (COPY FILE) key, no file or directory corresponding to the execution of the key was on the floppy disk.

114 **CAN'T SAVE GRAPHICS WHEN COPY IN PROGRESS**

You commanded to save the graphics screen during the execution of copying (outputting to a printer), but the graphics screen cannot be saved during output to a printer.

116 **NO STATE/DATA FILES ON MEMORY**

Though you attempted to display the list of files and directories on a volatile memory disk or nonvolatile memory disk (flash memory) on the softkey label by executing the recall ([Recall]) key, file resave (RE-SAVE FILE) key, file deletion (PURGE FILE) key, directory change (CHANGE DIRECTORY) key, file copy (COPY FILE) key, and so on, no file or directory corresponding to the execution of the key was on the volatile memory disk or nonvolatile memory disk (flash memory).

118 **DEVICE TYPE IS NOT DOS**

The execution of write access to the mass storage could not be executed because the format type of the mass storage was not DOS.

124 **LIST TABLE EMPTY OR INSUFFICIENT TABLE**

When the list sweep table was empty or insufficient, you attempted to select LIST as the sweep type (command: SWPT LIST) and, as a result, the command was ignored. Before selecting the list sweep as the sweep type, set the list sweep table correctly.

130 **CAN'T CHANGE ON ZERO SPAN**

During the execution of the list sweep when the sweep span of each segment was zero, you attempted to change the list sweep span (integrated total span of individual segments specified as the horizontal axis of the graph for the list sweep) to the single span (the way to specify a linear frequency axis for the horizontal axis of the graph whose left edge and right edge are the minimum frequency and the maximum frequency within all segments) using the LIST SPAN [ ] key or the LISPAN SINGLE command and, as a result, the command was ignored. When executing the list sweep while the sweep span of each segment being zero, the list sweep span is automatically set to the segment span and cannot be changed.

131 **FREQUENCY SWEEP ONLY**

When a sweep parameter other than the frequency was specified, you attempted to execute an equivalent circuit analysis command (CALECPARA and so on). You can execute the equivalent circuit analysis only when the sweep parameter is the frequency.

132 **LIST SWEEP ONLY**

When a sweep type other than the list sweep was specified, you attempted to execute a command to specify all segments (entire sweep range) as the search range setting (SEARNG FULL) or a command to specify a certain segment as the search target (SEGMNUM <value>) and, as a result, the command was ignored. Before setting the search range for the list sweep, specify the list sweep as the sweep type (command: SWPT LIST).

133 **CAN'T CHANGE ON LIST SWEEP**

When the sweep type was set to the list sweep, you attempted to execute a command to

specify the lower limit of a partial search range (SEARMIN) or a command to specify the upper limit of a partial search range (SEARMAX) and, as a result, the command was ignored. When the sweep type is the list sweep, you cannot specify a partial search range using the lower limit and the upper limit. Before specifying a partial search range using the lower limit and the upper limit, specify a sweep type other than the list sweep (command: SWPT LIN or SWPT LOG).

134 **REDUCE OSC LEVEL**

The oscillator level is considerably higher than the measured  $|Z|$  (absolute value of impedance) of the DUT, causing increased nonlinear measurement error that cannot be ignored. This message is displayed when the oscillator level is set to greater than 0.5 V while  $|Z|$  of the DUT is smaller than 48  $\Omega$ . To avoid this error, set the oscillator level below 0.5 V.

135 **ADC OVERLOAD**

Due to, for example, a sudden change of the connection of a DUT, the internal circuit (ADC) was temporarily overloaded. Measurement data at the occurrence of this error is invalid. If this error often occurs in usual measurements, the instrument may fail. In this case, Contact your local Agilent Technologies sales office or the company you purchased this instrument from.

136 **BRIDGE UNBALANCED**

Because the connection of a DUT or the setting for it was incorrect, the internal circuit (BRIDGE) temporarily could not perform measurements (UNBALANCED).

- The setting of the four-terminal pair extension (NONE, 4TP 1M, 4TP 2M, 7mm 42942A, PROBE 42941A) may not match with the fixture, cable, adapter, or probe actually connected. Check and correct the setting.
- The setup (acquisition of calibration data) for the setting of the four-terminal pair extension may have failed. If necessary, perform the setup again.
- Some measured DUTs may cause this error due to their characteristics. In this case, the error may be avoided by changing the measurement condition (for example, lowering the measurement signal level).

If this error often occurs in usual measurements, the instrument may fail. In this case, Contact your local Agilent Technologies sales office or the company you purchased this instrument from.

137 **DCBIAS OVERLOAD**

When the DC bias was applied, DC current that exceeded the setting of the DC bias range (<1mA, <10mA, or <100mA) was supplied from the bias source, or the overcurrent limit circuit of the DC bias source operated. Increase the setting of the DC bias range, or decrease the level of the applied DC bias.

138 **DCBIAS CONSTANT OPERATION FAILED**

When the DC bias mode was constant voltage (VOLT CONSTANT) or constant current (CURRENT CONSTANT), the actual DC bias output did not converge to the set DC voltage value or DC current value, or it exceeded the set voltage limit or current limit. If a DUT needs time to be stabilized after DC bias is applied, specify the point delay. If necessary, change the voltage limit value or the current limit value.

139 **DCBIAS LEVEL MONITOR NOT VALID**

When the DC bias level monitor was not on, you attempted to execute the command to turn

## Error messages

### Error number: 140

on the marker DC voltage level monitor or the marker DC current level monitor (MKRMON DCV or MKRMON DCI) and, as a result, the command was ignored. Before turning on the marker DC voltage level monitor or the marker DC current level monitor, turn on the corresponding DC bias level monitor (command: BMON VOLT or BMON CURR).

#### 140 **OSC LEVEL MONITOR NOT VALID**

When the oscillator level monitor was not on, you attempted to execute a command to turn on the marker AC voltage level monitor or the marker AC current level monitor (MKRMON ACV or MKRMON ACI) and, as a result, the command was ignored. Before turning on the marker AC voltage level monitor or the marker AC current level monitor, turn on the AC bias level monitor (command: OMON ON).

#### 141 **INSUFFICIENT MEMORY**

Multiple processes were executed at the same time and the memory was exhausted, which caused the last process to be aborted. For example, if the execution of an HP Instrument BASIC program, the printout of the screen, and the transfer of the data array are executed at the same time, the memory of the system is exhausted, and this message may be displayed. In this case, terminate some of the processes and then perform the next operation.

#### 142 **WRONG I/O PORT DIRECTION**

For a 24-bit input/output (I/O) shared port (port C and port D), you attempted to execute input/output (I/O) of data in the direction opposite from the preset input/output direction. The command was invalid. For example, if you use the CIN command to specify port C as an input port and then use the OUTCIO <value> command to output data from port C, this error is displayed.

#### 143 **FLOATING POINT ERROR OCCURED**

Due to the execution of an application inside the instrument for inappropriate data sent from outside the instrument, an error for floating point operations occurred inside the instrument. The result of the operation may be incorrect. Contact your local Agilent Technologies sales office or the company you purchased this instrument from.

#### 154 **INVALID DATE**

You attempted to specify the date of the built-in clock using the DATE key or the SETCDATE command, but the date was out of range and, as a result, the setting you attempted to execute became invalid. The settable range is: 1900 to 2099 for year, 1 to 12 for month, and 1 to 31 for day. Also, you cannot specify a date that does not exist actually. Specify correct date data.

#### 193 **POWER ON TEST FAILED**

In the power-on self-test, a fault of the instrument was detected. Contact your local Agilent Technologies sales office or the company you purchased this instrument from.

#### 194 **EEPROM WRITE FAIL**

A write error was detected in the memory (EEPROM) to store the OPEN, SHORT, and LOAD data for the four-terminal pair extension setting. Contact your local Agilent Technologies sales office or the company you purchased this instrument from.

#### -100 **Command error**

A comprehensive syntax error occurred for which the 4294A could not detect further details of the error. This error code simply indicates the occurrence of a command error

that is defined in IEEE488.2,11.5.1.1.4.

- 101 **Invalid character**  
Invalid characters exist in the program message string. For example, for a correct program message, "MEAS IRIM," an ampersand (&) is inserted by mistake, like "MEAS&IRIM".
- 102 **Syntax error**  
There is a command or data type that cannot be recognized. For example, though the 4294A did not accept any strings, a string was received.
- 103 **Invalid separator**  
The parser (syntax analysis program) expected a separator, but a character other than a separator was sent. For example, though the correct way is using ";" to separate 2 sent program messages like "MEAS IRIM;FMT LOGY", a semicolon (;) to separate the program messages is missing, like "MEAS IRIM FMT LOGY".
- 104 **Data type error**  
The parser recognized impossible data elements. For example, numeric value or string data was expected, but block data was sent.
- 105 **GET not allowed**  
A group execution trigger (GET) was received in a program message. (Refer to IEEE488.2,7.7.)
- 108 **Parameter not allowed**  
The number of parameters is larger than that the command requires. For example, though the "POIN" command requires 1 parameter like "POIN 101," 2 parameters are added like "POIN 101,1."
- 109 **Missing parameter**  
The number of parameters is less than that the command requires. For example, though the "POIN" command requires 1 parameter like "POIN 101," no parameter is added like "POIN."
- 111 **Header separator error**  
The header separator is wrong.  
This error is displayed when a character other than a defined header follows the header. For example, when, though "\*SRE 4" is correct, a character follows the header without a space like "\*SRE4", this error is displayed.
- 112 **Program mnemonic too long**  
The length of the header exceeds 12 characters. (Refer to IEEE488.2,7.6.1.4.1.)
- 113 **Undefined header**  
A header not defined for the 4294A was received. For example, "\*XYZ" not defined for the 4294A was received.
- 114 **Headers Suffix out of range**  
The suffix of the header is out of range. The suffix of a numeral parameter that follows the SCPI command makes the header invalid.
- 120 **Numeric data error**

## Error messages

### Error number: -121

Numeric data (including numeric data without a decimal point) causes an error. A numeric value error other than -121 to -129 occurred.

-121

#### **Invalid character in number**

An invalid character for the data type of the syntax analysis target was received. For example, alphabetical characters exist in a decimal value, or "9" exists in octal data.

-123

#### **Exponent too large**

The absolute value of the exponent exceeds 32,000. (Refer to IEEE488.2,7.7.2.4.1.)

-124

#### **Too many digits**

The number of digits of the mantissa of the decimal value data element exceeds 255 except preceding 0s. (Refer to IEEE488.2,7.7.2.4.1.)

-128

#### **Numeric data not allowed**

A numeric value data element (that did not violate the standard) was received at where the 4294A did not accept any numeric value data elements.

-130

#### **Suffix error**

A suffix error.

An error other than -131 to -139 occurred in the notation of a suffix.

-131

#### **Invalid suffix**

The suffix does not meet the syntax defined in IEEE488.2,7.7.3.2 or it is inappropriate for the 4294A.

-134

#### **Suffix too long**

The suffix is too long.

The suffix contains the notation of 12 characters or more. (Refer to IEEE488.2,7.7.3.4.)

-138

#### **Suffix not allowed**

A suffix is added to a numeric value element to which no suffix can be added.

-140

#### **Character data error**

An error not included in error numbers between -141 and -149 occurred during the syntax analysis of a character data element.

-141

#### **Invalid character data**

There are invalid characters in a character data element or the received parameter is not valid. For example, though a correct program message was "MEAS LSR," a wrong program message, "MEAS LSD," was received.

-144

#### **Character data too long**

The length of the character data element exceeds 12 characters. (Refer to IEEE488.2,7.7.1.4.)

-148

#### **Character data not allowed**

A character data element (that did not violate the standard) was received at where the 4294A did not accept any character data elements. For example, a parameter must be enclosed with double quotation marks (") but they are missing.

- 150           **String data error**  
An error not included in error numbers between -151 and -159 occurred during the syntax analysis of a string data element.
- 151           **Invalid string data**  
Character string data was expected but given string data was invalid for some reasons. (Refer to IEEE488.2,7.7.5.2.) For example, the END message was received before the end quotation mark character appeared.
- 158           **String data not allowed**  
A string data element was received at where the 4294A did not accept any string data elements.
- 160           **Block data error**  
An error not included in error numbers between -161 and -169 occurred during the syntax analysis of block data.
- 161           **Invalid block data**  
Block data was expected but given block data was invalid for some reasons. (Refer to IEEE488.2,7.7.6.2.) For example, the END message was received before the length of the block data was reached.
- 168           **Block data not allowed**  
A block data element was received at where the 4294A did not accept any block data elements.
- 170           **Expression error**  
An error not included in error numbers between -171 and -179 occurred during the syntax analysis of equation data.
- 171           **Invalid expression**  
The equation data element is invalid. (Refer to IEEE488.2,7.7.7.2.) For example, parentheses are not paired or a character violates the standard.
- 178           **Expression data not allowed**  
An equation data element was received at where the 4294A did not accept any equation data elements.
- 200           **Execution error**  
A comprehensive execution error occurred for which the 4294A could not detect further details of the error. This error code simply indicates the occurrence of an execution error that is defined in IEEE488.2,11.5.1.1.5.
- 210           **Trigger error**  
A trigger error. An error other than -211 to -219 occurred.
- 211           **Trigger ignored**  
A trigger command or trigger signal was received and recognized by the 4294A, but it was ignored due to the timing relationship with the 4294A (for example, when the 4294A was not ready to respond).
- 213           **Init ignored**

## Error messages

### Error number: -220

Another measurement was being executed and the measurement start request was ignored.

-220

#### **Parameter error**

An error not included in error numbers between -221 and -229 occurred during the analysis of a program data element. This error occurs, for example, when you attempt to specify an invalid value for the LOAD correction reference value or the LOAD correction data (values that are not finite when converted to R-X form impedance values). If this error occurs, the command is ignored. This error also occurs when you attempt to specify an invalid LOAD correction reference value from front panel keys.

-221

#### **Setting conflict**

A program data element complying with the syntax standard was analyzed but the 4294A could not execute it at present.

-222

#### **Data out of range**

A data element (that did not violate the standard) out of the range the 4294A defined was received.

-223

#### **Too much data**

The received block, equation, or string type program data complied with the standard but its amount exceeded the limit that the 4294A could deal with, due to memory or device-specific conditions related to memory.

-224

#### **Illegal parameter value**

The value of the parameter is illegal.

-225

#### **Data out of memory**

To perform the requested operation, the 4294A does not have enough memory.

-230

#### **Data corrupt or stale**

The data may be invalid. Or, a newly initiated read operation has not been completed since the latest access.

-231

#### **Data questionable**

Data may be questionable. The accuracy of measurement data may be deteriorated.

-240

#### **Hardware error**

A hardware error.

The program command could not be executed due to an hardware-related error. An error other than -241 to -249 occurred.

-241

#### **Hardware missing**

The received command or Query complied with the standard but could not be executed due to hardware-related reasons (for example, the option was not installed).

-250

#### **MASS STORAGE ERROR**

A mass storage error occurred.

A mass storage error other than -257 occurred.

-252

#### **Missing media**

You attempted to access the storage device, but media did not exist or was not installed



correctly. This message is displayed, for example, when you specifies the floppy disk drive as the storage device but no floppy disk is set into the drive (correctly).

-256

**File name not found**

The specified filename was not found and, as a result, the command was not executed correctly. This message is displayed, for example, when you attempt to read/write a file that does not exist on the disk.

-257

**FILE NAME ERROR**

There was an error in the filename and, as a result, the command was not executed correctly.

This message is displayed, for example, when you attempt to copy a file using the same filename.

-258

**Media protected**

You attempted to save/delete data to/from the storage device or initialize the media, but the media was write-protected, and, as a result, the operation could not be executed. This message is displayed, for example, when you have specified the floppy disk drive as the storage device and a floppy disk is write-protected. If necessary, disable the write-protection for the floppy disk.

-280

**Program error**

A program error.

An error occurred in a downloaded program. An error other than -281 to -289 occurred.

-281

**Cannot create program**

Programs cannot be created. Insufficient memory is suspected.

-282

**Illegal program name**

The program name is illegal. This message is displayed, for example, when you attempt to delete a program name that does not exist, define an existing program name again, or refer to a program that does not exist.

-283

**Illegal variable name**

The variable name is illegal. This message is displayed when you attempt to refer to a variable that does not exist.

-284

**Program currently running**

The program is running.

This message is displayed when you attempt to perform an operation that cannot be executed during the execution of a program. For example, when you attempt to delete a running program.

-285

**Program syntax error**

A program syntax error.

A program syntax error occurred in the downloaded program.

-286

**Program runtime error**

An error occurred while an HP Instrument BASIC program is being executed. To obtain detailed information on the occurred error, use theERRM\$ or ERRM command of HP Instrument BASIC.

## Error messages

### Error number: -310

-310

#### **System error**

One of "system errors" defined for the 4294A occurred.

-311

#### **Memory error**

An error was detected in the memory of the 4294A.

-330

#### **Self-test failed**

The result of the self-test was a failure. Contact your local Agilent Technologies sales office or service center, or refer to the service manual.

-350

#### **Queue overflow**

The queue contains a certain code, instead of the code that caused this error. This code indicates that an error has occurred due to insufficient space in the queue but it has not been recorded.

-400

#### **Query error**

A comprehensive Query error occurred for which 4294A could not detect further details of the error. This code simply indicates the occurrence of a Query error that is defined in IEEE488.2,11.5.1.1.7 and 6.3.

-410

#### **Query INTERRUPTED**

Status that causes an "INTERRUPTED" Query error. (Refer to IEEE488.1,6.3.2.3.) This error occurs, for example, when, after Query, data byte (DAB) or GET is received before the response has been sent completely.

-420

#### **Query UNTERMINATED**

Status that causes an "UNTERMINATED" Query error. (Refer to IEEE488.2,6.3.2.) This error occurs, for example, when the 4294A is specified as a talker and an incomplete program message is received.

-430

#### **Query DEADLOCKED**

Status that causes a "DEADLOCKED" Query error. (Refer to IEEE488.2,6.3.1.7.) This error occurs, for example, when both input and output buffers become full and the 4294A cannot continue processing.

-440

#### **Query UNTERMINATED after indefinite response**

In a certain program message, after a Query that requested an ambiguous response was executed, another Query was received. (Refer to IEEE488.2,6.5.7.5.7.)

**Symbols**

- Δ marker, 96
  - move
    - specified measurement point, 294
    - specified sweep parameter value, 295
  - on/off, 292
  - read marker value
    - measurement parameter value, 296
    - measurement/sweep parameter value, 366
    - secondary measurement parameter value, 293
    - sweep parameter value, 295

**Numerics**

- 16451B, 190
- 16454A, 213
- 24 bit I/O port, 122
  - data input
    - port C, 370
    - port D, 371
    - port E, 371
  - data output
    - port A, 358
    - port B, 358
    - port C, 359
    - port D, 359
    - port E, 360
    - port F, 360
    - port G, 361
    - port H, 361
  - INPUT1 pulse input check, 308
  - logic setting
    - negative logic, 351
    - positive logic, 392
  - OUTPUT1 setting
    - high level/low level, 356
    - operation when INPUT1 detects pulse input, 356
  - OUTPUT2 setting
    - high level/low level, 357
    - operation when INPUT1 detects pulse input, 357
  - port C setting
    - set input port, 270
    - set output port, 275
  - port D setting
    - set input port, 287
    - set output port, 297
- 8 bit I/O port, 120
  - data input, 308
  - data output, 357

**A**

- accumulate display on/off, 255
- active trace, 40, 444
- adapter setting, 54
  - adapter selection, 299
  - data measurement
    - measurement, 299
    - measurement cancel, 300
  - measurement
    - calculate and store, 299
  - address setting
    - 4294A IP address, 257
    - controller HP-IB address, 255
    - gateway IP address, 256
  - allocation, 288
  - analysis
    - equivalent circuit analysis
      - equivalent circuit model
        - display on/off, 288
        - selection, 301
      - equivalent circuit parameter
        - calculation, 267
        - display on/off, 289
        - read/definition, 286
      - frequency response simulation, 424
    - statistical analysis
      - on/off, 338
      - read analysis result, 377
    - trace bandwidth analysis
      - cutoff point
        - definition type, 449
        - fixed value setting, 447
      - inside cutoff point search, 447
      - on/off, 448
      - outside cutoff point search, 448
      - read analysis result, 379
    - waveform analysis
      - command
        - maximum and minimum values search, 375
        - maximum difference between positive and negative
          - peaks
            - value, 400
            - value and position, 401
          - maximum difference between positive peak and its
            - adjacent negative peak
              - both sides, 400
              - left side, 400
              - right side, 401
            - maximum positive peak search, 386
            - maximum value search, 373
            - minimum negative peak search, 353
            - minimum value search, 375
            - next maximum positive peak search, 352
            - next minimum negative peak search, 351
            - n-th negative peak search, 333
            - n-th positive peak search, 332
          - resonator analysis
            - 0-phase point, 380
            - 0-phase point and ripple, 381
            - ceramic resonator parameter, 362
            - equivalent circuit parameters of crystal resonator, 302
            - parallel capacitance, 301
            - specified measurement parameter value search
              - to left, 437

- to right, 438
- condition
  - analysis range setting
    - full sweep range, 260
    - specified range, 259
  - analysis segment selection, 260
  - analysis trace selection
    - data trace, 258
    - memory trace, 258
  - peak definition, 439
- ASCII format, 78, 306
- auto scale, 260
- AUTOREC.STA, 408
- AUTOST, 143
- averaging, 43
  - measurement point
    - factor, 385
    - on/off, 385
  - sweep
    - factor, 261
    - on/off, 261
    - restart, 261

## B

- backlight on/of, 264
- bandwidth
  - analysis, 448
  - cutoff point
    - definition type, 449
    - fixed value setting, 447
    - inside cutoff point search, 447
    - outside cutoff point search, 448
  - read analysis result, 379
  - measurement condition, 266
- bandwidth analysis, 103
- beep
  - completion of operation, 262
  - error, 263
  - limit test fail, 263

## C

- calibration, 58
- calibration data array, 82
- clear register, 250, 271
- clock
  - date setting, 423
  - time setting, 424
- compensation
  - fixture compensation, 63
  - port extension compensation, 70
- compensation data array, 83
- complex plane format, 42
- controller HP-IB address, 255
- copy, 305
- copy data to memory, 277
- current directory change, 270

## D

- $\Delta$  marker, 96
- move
  - specified measurement point, 294
  - specified sweep parameter value, 295
- on/off, 292
- read marker value
  - measurement parameter value, 296
  - measurement/sweep parameter value, 366
  - secondary measurement parameter value, 293
  - sweep parameter value, 295
- data array, 81
- data flow, 81
- data measurement
  - adapter setup
    - calculate and store, 299
    - measurement, 299
    - measurement cancel, 300
  - fixture compensation, 273
  - user calibration
    - calculate and store, 266
    - measurement, 266
    - measurement cancel, 267
- data read/write
  - read
    - data array
      - all points, 364
      - specified point, 364
    - data trace array
      - all points, 367
      - specified point, 368
    - error queue, 369
    - fixture compensation data array, 363
    - level monitor result
      - dc bias
        - all point, 365
        - specified point, 365
      - OSC
        - current
          - all points, 369
          - specified point, 370
        - voltage
          - all points, 383
          - specified point, 384
    - limit test result
      - all points, 372
      - failed points, 372
      - marker position, 373
      - number of failed points, 369
    - memory array
      - all points, 374
      - specified point, 374
    - memory trace array
      - all points, 377
      - specified point, 378
    - sweep parameter array
      - all points, 383

- specified point, 383
    - user calibration data array, 362
  - write
    - data array, 310
    - data trace array, 311
    - fixture compensation data array, 310
    - user calibration data array, 309
  - data trace array, 82
  - data transfer format, 78
  - date display format, 297
  - dc bias, 38
    - level
      - current, 281
      - maximum voltage, 336
      - minimum voltage, 339
      - voltage, 285
    - level monitor setting, 264
    - mode, 281
    - on/off, 282
    - range, 284
  - device selector, 28
  - dielectric material, 190
  - directory
    - create, 276
    - move, 270
  - disk format, 308
  - display
    - accumulate on/off, 255
    - allocation setting, 288
    - backlight on/off, 264
    - copy data to memory, 277
    - displayed trace setting, 291
    - expanded phase display on/off, 304
    - format setting, 305
    - level monitor setting
      - dc bias, 264
      - OSC, 354
    - non-active trace display on/off, 307
    - offset value setting, 277
    - on/off, 411
    - phase unit setting, 387
    - scale
      - auto scaling, 260
      - coupled scale on/off, 409
      - grid
        - complex plane format
          - reference value
            - x-axis, 398
            - y-axis, 398
          - scale/div setting, 410
        - linear/log y-axis format
          - maximum value, 443
          - minimum value, 265
          - reference
            - position, 396
            - value, 397
          - scale/div setting, 410
    - polar chart format
      - full scale value, 397
      - setting target trace selection, 409
    - title setting, 441
    - trace A/B split display on/off, 430
  - display scale, 41
  - displayed item selection
    - limit line table, 289
    - list sweep table, 289
    - measurement condition parameter list, 354
    - measurement result list, 330
      - next page, 352
      - previous page, 393
    - standard definitions(fixture comp.), 273
    - standard definitions(user cal.), 267
    - trace, 399
  - dynamic data disk, 171
- ## E
- equivalent circuit analysis, 100
  - equivalent circuit model
    - display on/off, 288
    - selection, 301
  - equivalent circuit parameter
    - calculation, 267
    - display on/off, 289
    - read/definition, 286
    - frequency response simulation, 424
  - error message
    - how to read, 133
    - list, 480
  - error queue, 133
  - ÉtÉ@ÉCÉäÉÄÇİ
    - ÉZÁ, 405
    - ÉZÁ, 405
  - expanded phase display on/off, 304
  - external trigger polarity, 445
- ## F
- file
    - copy, 305
    - delete
      - delete file, 395
  - file content update, 399
  - firmware version, 251
  - fixed measurement point, 267
  - fixture compensation, 63
    - data array, 83
    - data measurement, 273
    - data measurement point setting, 267
    - data writing, 310
    - on/off, 274
    - read data, 363
    - standard
      - definition
        - display value, 273
        - load, 282

- open, 283
- short, 284
- form 2, 79, 306
- form 3, 80, 306
- form 4, 78, 306
- form 5, 80, 306
- format, 41
- formfeed, 307
- front panel key
  - disable, 298
  - enable, 300
  - send key code, 312
- FTP, 167
- ftp, 167
  
- G**
- gateway IP address setting
  - command, 256
  - front panel key, 166
  
- H**
- handling errors, 131
- HP 4294A IP address setting
  - command, 257
  - front panel key, 165
- HP-IB command
  - command list sorted according to function, 469
  - command reference
    - HP 4294A command, 255
    - IBASIC control command, 451
    - IEEE common command, 250
    - notational conventions, 248
  
- I**
- I/O port, 120
- 24 bit I/O port
  - data input
    - port C, 370
    - port D, 371
    - port E, 371
  - data output
    - port A, 358
    - port B, 358
    - port C, 359
    - port D, 359
    - port E, 360
    - port F, 360
    - port G, 361
    - port H, 361
- INPUT1 pulse input check, 308
- logic setting
  - negative logic, 351
  - positive logic, 392
- OUTPUT1 setting
  - high level/low level, 356
  - operation when INPUT1 detects pulse input, 356
- OUTPUT2 setting
  - high level/low level, 357
  - operation when INPUT1 detects pulse input, 357
- port C setting
  - set input port, 270
  - set output port, 275
- port D setting
  - set input port, 287
  - set output port, 297
- 8 bit I/O port
  - data input, 308
  - data output, 357
- IEEE 32 bit floating point format, 79, 306
- IEEE 64 bit floating point format, 80, 306
- initialize floppy disk, 308
- instrument status event register, 465
  - read value, 303
  - set enable register, 304
- intensity, 311
- internal data array, 81
- IP address setting
  - 4294A IP address, 257
  - gateway address, 256
  
- K**
- key code, 312
- keylock, 298
  
- L**
- LAN, 163
  - displaying MAC address, 166
  - dynamic data disk, 171
  - FTP, 167
  - gateway IP address setting
    - command, 256
    - front panel key, 166
  - HP 4294A IP address setting
    - command, 257
    - front panel key, 165
  - subnet mask setting
    - command, 434
    - front panel key, 166
  - telnet, 174
- LCD
  - backlight on/of, 264
  - display element setting
    - brightness, 268
    - chroma, 273
    - target element selection, 272
    - tint, 441
  - reset
    - all settings, 285
    - specified element, 401
  - screen
    - background intensity, 262
    - intensity, 311
- level monitor setting

- dc bias, 264
- OSC, 354
- limit range offset
  - limit value offset, 316
  - sweep parameter value offset, 316
- limit test
  - beep on/off, 263
  - how to set, 46
  - limit line table
    - clear, 313
    - done, 315
    - edit, 300
  - limit range offset
    - limit value offset, 316
    - sweep parameter value offset, 316
  - on/off, 317
  - segment
    - abort segment edit, 322
    - add, 319
    - delete, 320
    - done, 320
    - edit, 321
    - parameter setting
      - limit
        - start
          - delta, 314
          - lower value, 317
          - middle value, 328
          - upper value, 326
        - stop
          - delta, 315
          - lower value, 318
          - middle value, 329
          - upper value, 327
        - start value, 323
        - stop value, 325
        - test on/off, 324
      - select target segment, 322
  - test result output
    - all measurement points, 372
    - failed measurement points, 372
    - marker position, 373
    - number of failed measurement points, 369
- linear Y axis format, 41
- list sweep
  - how to set, 44
  - segment
    - add, 402
    - delete, 412
    - done, 413
    - edit, 421
    - parameter setting
      - bandwidth, 266
      - dc bias
        - level
          - current, 281
          - voltage, 285
        - mode, 281
        - number of points, 390
        - OSC level
          - setting, 392
          - setting mode, 393
        - point averaging factor, 385
        - sweep range
          - center value, 269
          - span, 429
          - start value, 431
          - stop value, 433
        - trace color, 411
        - select target segment, 422
    - span display type selection, 330
    - table
      - clear, 271
      - done, 300
      - edit, 300
  - log Y axis format, 41

## M

  - MAC address, 166
  - magnetic material, 213
  - marker, 96
    - $\Delta$  marker
      - move
        - specified measurement point, 294
        - specified sweep parameter value, 295
      - on/off, 292
      - read marker value
        - measurement parameter value, 296
        - measurement/sweep parameter value, 366
        - secondary measurement parameter value, 293
        - sweep parameter value, 295
    - level monitor value display mode, 344
    - list function on/off, 341
    - move
      - specified measurement point, 346
      - specified sweep parameter value, 347
    - movement mode(continuous/discrete), 344
    - on/off, 339
    - read marker value
      - measurement parameter value, 349
      - measurement/sweep parameter value, 376
      - secondary measurement parameter value, 340
      - sweep parameter value, 347
    - sub marker
      - move
        - specified measurement point, 426
        - specified sweep parameter value, 427
      - on/off, 425
      - read marker value
        - measurement parameter value, 428
        - measurement/sweep parameter value, 382
        - secondary measurement parameter value, 425
        - sweep parameter value, 427
      - target trace selection (data/memory), 345

- trace A/B coupled mode on/off, 341
  - unit of sweep parameter value, 350
  - marker search
    - maximum value search, 414
    - minimum value search, 414
    - peak definition
      - automatic definition using marker, 346
      - $\Delta X$  value setting, 388
      - $\Delta Y$  value setting, 389
      - polarity setting, 389
    - peak search, 414
      - next peak, 414
      - next peak left, 414
      - next peak right, 415
    - search range setting
      - between marker and delta marker, 348
      - lower limit
        - marker position, 349
        - specified measurement point, 419
        - specified sweep parameter value, 418
      - partial search on/off, 384
      - upper limit
        - marker position, 348
        - specified measurement point, 417
        - specified sweep parameter value, 416
    - search range setting for list sweep
    - search range line on/off, 415
    - search range(all segments/specified segment), 419
    - search segment selection, 423
    - search tracking function on/off, 444
    - target search, 414
      - left target, 413
      - right target, 415
      - target line display on/off, 420
      - target value setting, 420
  - material
    - dielectric material, 190
    - magnetic material, 213
  - maximum value search, 414
  - measurement condition setting, 252
    - active trace, 444
    - averaging
      - measurement point
        - factor, 385
        - on/off, 385
      - sweep
        - factor, 261
        - on/off, 261
        - restart, 261
    - bandwidth, 266
    - dc bias
      - level
        - current, 281
        - maximum voltage, 336
        - minimum voltage, 339
        - voltage, 285
      - mode, 281
      - on/off, 282
      - range, 284
    - how to set, 35
      - active trace, 40
      - averaging, 43
      - dc bias, 38
      - display format, 41
      - display scale, 41
      - limit test, 46
      - list sweep, 44
      - measurement parameter, 36
      - oscillator (OSC), 38
      - sweep condition, 39
      - trace setting, 40
    - measurement parameter, 337
    - number of measurement points, 390
  - OSC
    - frequency, 276
    - level
      - setting, 392
      - setting mode, 393
  - preset, 252, 393
  - sweep
    - delay time
      - measurement point, 386
      - sweep, 413
    - direction, 435
    - manual sweep
      - on/off, 336
      - specifying point, 334
      - specifying range, 335
    - parameter, 436
    - range
      - center value, 269
      - span value, 429
      - start value, 431
      - stop value, 433
      - time, 435
      - type, 436
    - measurement parameter, 337
    - measurement parameter setting, 36
  - measuring dielectric material, 190
  - measuring magnetic material, 213
  - memory array, 81
  - memory trace array, 82
  - minimum value search, 414
  - MS-DOS personal computer format, 80, 306
- N**
- non-active trace display on/off, 307
  - number of measurement points, 390
- O**
- ON KEY LABELS, 446
  - operation status register, 465
  - read condition register, 356
  - read event register, 355



- set enable register, 354
- set negative filter, 355
- set positive filter, 356
- option information, 252
- OSC
  - frequency, 276
  - level
    - setting, 392
    - setting mode, 393
  - level monitor setting, 354
- oscillator (OSC), 38
- overlap command, 254
  
- P**
- peak definition
  - marker search
    - automatic definition using marker, 346
    - $\Delta X$  value setting, 388
    - $\Delta Y$  value setting, 389
    - polarity setting, 389
- peak search, 414
  - next peak, 414
  - next peak left, 414
  - next peak right, 415
- permeability, 213
- permittivity, 190
- phase unit setting, 387
- point averaging
  - factor, 385
  - on/off, 385
- polar chart format, 42
- port 23, 174
- port 5025, 174
- port extension compensation, 70
  - on/off, 390
  - setting
    - delay time, 391
    - electrical length, 391
- preset, 252, 393
- print
  - aborts printout, 274
  - displayed item selection
    - limit line table, 289
    - list sweep table, 289
    - measurement condition parameter list, 354
    - measurement result list, 330
    - next page, 352
    - previous page, 393
    - standard definitions(fixture comp.), 273
    - standard definitions(user cal.), 267
    - trace, 399
  - printout, 394
  - setting
    - color, 394
    - direction(landscape/portrait), 313
    - formfeed, 307
    - left margin, 331
- reset, 287
- resolution, 298
- softkey label print on/off, 394
- time stamp on/off, 275
- top margin, 442
- product information, 251
- program message terminator, 29
  
- R**
- read
  - $\Delta$  marker value
    - measurement parameter value, 296
    - measurement/sweep parameter value, 366
    - secondary measurement parameter value, 293
    - sweep parameter value, 295
  - data array
    - all points, 364
    - specified point, 364
  - data trace array
    - all points, 367
    - specified point, 368
  - error queue, 369
  - fixture compensation data array, 363
  - how to read, 84
  - level monitor result
    - dc bias
      - all point, 365
      - specified point, 365
  - OSC
    - current
      - all points, 369
      - specified point, 370
    - voltage
      - all points, 383
      - specified point, 384
  - limit test result
    - all points, 372
    - failed points, 372
    - marker position, 373
    - number of failed points, 369
  - marker value
    - measurement parameter value, 349
    - measurement/sweep parameter value, 376
    - secondary measurement parameter value, 340
    - sweep parameter value, 347
  - memory array
    - all points, 374
    - specified point, 374
  - memory trace array
    - all points, 377
    - specified point, 378
  - sub marker value
    - measurement parameter value, 428
    - measurement/sweep parameter value, 382
    - secondary measurement parameter value, 425
    - sweep parameter value, 427
  - sweep parameter array

- all points, 383
- specified point, 383
- user calibration data array, 362
- recall, 395
- resave, 399
- reset, 252, 393
  - LCD setting
    - all, 285
    - specified, 401
  - print setting, 287
- S**
- sample program
  - adapter.bas, 55
  - alc.bas, 225
  - ana\_com.bas, 108
  - band\_ana.bas, 105
  - bsc\_meas.bas, 187
  - ceramic resonator parameter analysis, 108
  - circuit.bas, 101
  - color.bas, 245
  - com\_inpu.bas, 68
  - com\_meas.bas, 65
  - communication with external equipment, 129
  - control with Visual Basic, 176
  - ctrl\_lan.xls, 176
  - data entry for fixture compensation, 68
  - data measurement for adapter setting, 55
  - data measurement for fixture compensation, 65
  - data measurement for user calibration, 61
  - data\_b2a.bas, 84
  - detecting of an error via SRQ, 135
  - detecting the completion of sweep using the \*OPC?, 76
  - detecting the completion of sweeps using an SRQ, 75
  - dielectric (relative permittivity) measurement (contact method), 197
  - dielectric (relative permittivity) measurement (non-contact method), 205
  - equivalent circuit analysis, 101
  - error.bas, 135
  - file\_sav.bas, 117
  - how to load, 22
  - io\_port.bas, 129
  - lim\_test.bas, 91
  - lvl\_mon.bas, 88
  - magnetic substance (relative permeability) measurement, 218
  - marker.bas, 99
  - measurement controlling oscillator level, 225
  - measuring the self-resonant point of a capacitor, 187
  - mem2dat.bas, 86
  - permeabi.bas, 218
  - permi\_c.bas, 197
  - permi\_nc.bas, 205
  - prg\_xfer.bas, 150
  - reading level monitoring results, 88
  - reading limit test results, 91
  - reading/writing data trace array in a binary format, 86
  - reading/writing data trace array in the ASCII format, 84
  - save/recall, 117
  - scanner, 234
  - searching for peaks using the marker, 99
  - setting colors in the LCD screen, 245
  - setting measurement conditions, 50
  - setup.bas, 50
  - swp\_opc.bas, 76
  - swp\_srq.bas, 75
  - trace bandwidth analysis, 105
  - transferring a program to Instrument BASIC, 150
  - user\_cal.bas, 61
- save
  - internal data arrays
    - save
      - ASCII file, 403
      - binary file, 404
      - touchstone file, 405
    - select
      - cal./compen. data array, 403
      - data array, 404
      - data trace array, 407
      - memory array, 407
      - memory trace array, 408
  - resave, 399
  - screen graphics, 406
  - state, 406
  - state as AUTOREC.STA, 408
  - storage device selection, 432
- scale, 41
  - auto scaling, 260
  - coupled scale on/off, 409
  - grid
    - complex plane format
      - reference value
        - x-axis, 398
        - y-axis, 398
      - scale/div setting, 410
    - linear/log y-axis format
      - maximum value, 443
      - minimum value, 265
      - reference
        - position, 396
        - value, 397
      - scale/div setting, 410
    - polar chart format
      - full scale value, 397
    - setting target trace selection, 409
- scanner, 229
- search range setting
  - between marker and delta marker, 348
  - lower limit
    - marker position, 349
    - specified measurement point, 419
    - specified sweep parameter value, 418
  - partial search on/off, 384

- upper limit
  - marker position, 348
  - specified measurement point, 417
  - specified sweep parameter value, 416
- search range setting for list sweep
- search range line on/off, 415
- search range(all segments/specified segment), 419
- search segment selection, 423
- search tracking function on/off, 444
- segment
  - limit test
    - abort segment edit, 322
    - add, 319
    - delete, 320
    - done, 320
    - edit, 321
    - parameter setting
      - limit
        - start
          - delta, 314
          - lower value, 317
          - middle value, 328
          - upper value, 326
        - stop
          - delta, 315
          - lower value, 318
          - middle value, 329
          - upper value, 327
        - start value, 323
        - stop value, 325
        - test on/off, 324
      - select target segment, 322
  - list sweep
    - add, 402
    - delete, 412
    - done, 413
    - edit, 421
    - parameter setting
      - bandwidth, 266
      - dc bias
        - level
          - current, 281
          - voltage, 285
        - mode, 281
      - number of points, 390
      - OSC level
        - setting, 392
        - setting mode, 393
      - point averaging factor, 385
      - sweep range
        - center value, 269
        - span, 429
        - start value, 431
        - stop value, 433
      - trace color, 411
      - select target segment, 422
- self test, 253
- serial number, 251
- serial number plate, 458
- service request enable register, 465
  - set value, 252
- setting measurement conditions, 35
- single span, 330
- single sweep, 424
- span display type selection, 330
- split display on/off, 430
- SRQ
  - handling errors, 132
  - waiting for completion of sweep, 74
- standard
  - fixture compensation
    - definition
      - display value, 273
      - load, 282
      - open, 283
      - short, 284
  - user calibration
    - definition
      - display value, 267
      - load, 278
      - open, 279
      - short, 280
- standard event status register, 465
  - read value, 251
  - set enable register, 250
- statistical analysis
  - on/off, 338
  - read analysis result, 377
- statistics analysis, 102
- status byte register, 465
  - read value, 253
- status register
  - handling errors, 132
  - structure, 465
  - waiting for completion of sweep, 74
- status reporting system, 461
  - clear register, 250, 271
  - read instrument event status register, 303
  - read operation status condition register, 356
  - read operation status event register, 355
  - read standard event status register, 251
  - set instrument event status enable register, 304
  - set operation status enable register, 354
  - set service request enable register, 252
  - set standard event status enable register, 250
  - set transition filter of operation status register
    - negative filter, 355
    - positive filter, 356
  - status byte register, 253
- storage device selection, 432
- sub marker, 96
  - move
    - specified measurement point, 426
    - specified sweep parameter value, 427

on/off, 425  
read marker value  
  measurement parameter value, 428  
  measurement/sweep parameter value, 382  
  secondary measurement parameter value, 425  
  sweep parameter value, 427  
subnet mask setting  
  command, 434  
  front panel key, 166  
sweep  
  delay time  
    measurement point, 386  
    sweep, 413  
  direction, 435  
  manual sweep  
    on/off, 336  
    specifying point, 334  
    specifying range, 335  
  mode  
    continuous, 274  
    hold, 307  
  operation  
    single, 424  
    specified number, 353  
  parameter, 436  
  range  
    center value, 269  
    span value, 429  
    start value, 431  
    stop value, 433  
  time, 435  
  type, 436  
sweep averaging  
  factor, 261  
  on/off, 261  
  restart, 261  
sweep condition, 39  
sweep mode, 72  
sweep parameter array, 83

## T

table  
  limit line  
    clear, 313  
    done, 315  
    edit, 300  
  list sweep  
    clear, 271  
    done, 300  
    edit, 300  
target search, 414  
  left target, 413  
  right target, 415  
  target line display on/off, 420  
  target value setting, 420  
telnet, 174  
test result output

  all measurement points, 372  
  failed measurement points, 372  
  marker position, 373  
  number of failed measurement points, 369  
title setting, 441  
trace A/B split display on/off, 430  
trace bandwidth analysis, 103  
  cutoff point  
    definition type, 449  
    fixed value setting, 447  
  inside cutoff point search, 447  
  on/off, 448  
  outside cutoff point search, 448  
  read analysis result, 379  
trace setting, 40  
trigger  
  event mode selection, 445  
  external trigger polarity, 445  
  HP-IB/LAN triggering, 253  
  source selection, 446  
trigger source, 72  
trigger system, 72  
triggering a measurement, 73

## U

user calibration, 58  
  data array, 82  
  data measurement  
    calculate and store, 266  
    measurement, 266  
    measurement cancel, 267  
  data measurement point setting, 267  
  data writing, 309  
  on/off, 268  
  read data, 362  
  standard  
    definition  
      display value, 267  
      load, 278  
      open, 279  
      short, 280  
user measurement point, 267

## W

wait for command operation completion, 254  
waiting for completion of sweep, 74  
waveform analysis, 106  
  command  
    maximum and minimum values search, 375  
    maximum difference between positive and negative peaks  
      value, 400  
      value and position, 401  
    maximum difference between positive peak and its  
      adjacent negative peak  
      both sides, 400  
      left side, 400  
      right side, 401

- 
- maximum positive peak search, 386
  - maximum value search, 373
  - minimum negative peak search, 353
  - minimum value search, 375
  - next maximum positive peak search, 352
  - next minimum negative peak search, 351
  - n-th negative peak search, 333
  - n-th positive peak search, 332
  - resonator analysis
    - 0-phase point, 380
    - 0-phase point and ripple, 381
    - ceramic resonator parameter, 362
    - equivalent circuit parameters of crystal resonator, 302
    - parallel capacitance, 301
    - specified measurement parameter value search
      - to left, 437
      - to right, 438
  - condition
    - analysis range setting
      - full sweep range, 260
      - specified range, 259
    - analysis segment selection, 260
    - analysis trace selection
      - data trace, 258
      - memory trace, 258
    - peak definition, 439
  - write
    - data array, 310
    - data trace array, 311
    - fixture compensation data array, 310
    - how to write, 84
    - user calibration data array, 309
- Z**
- zooming aperture, 450



## REGIONAL SALES AND SUPPORT OFFICES

*For more information about Agilent Technologies test and measurement products, applications, services, and for a current sales office listing, visit our web site: <http://www.agilent.com/find/tmdir>. You can also contact one of the following centers and ask for a test and measurement sales representative.* 11/29/99

### **United States:**

Agilent Technologies  
Test and Measurement Call Center  
P.O.Box 4026  
Englewood, CO 80155-4026  
(tel) 1 800 452 4844

(fax) (61 3) 9272 0749  
(tel) 0 800 738 378 (New Zealand)  
(fax) (64 4) 802 6881

### **Canada:**

Agilent Technologies Canada Inc.  
5150 Spectrum Way  
Mississauga, Ontario  
L4W 5G1  
(tel) 1 877 894 4414

### **Asia Pacific:**

Agilent Technologies  
24/F, Cityplaza One, 1111 King's Road,  
Taikoo Shing, Hong Kong  
(tel) (852)-3197-7777  
(fax) (852)-2506-9284

### **Europe:**

Agilent Technologies  
Test & Measurement  
European Marketing Organization  
P.O.Box 999  
1180 AZ Amstelveen  
The Netherlands  
(tel) (31 20) 547 9999

### **Japan:**

Agilent Technologies Japan Ltd.  
Call Center  
9-1, Takakura-Cho, Hachioji-Shi,  
Tokyo 192-8510, Japan  
(tel) (81) 426 56 7832  
(fax) (81) 426 56 7840

### **Latin America:**

Agilent Technologies  
Latin American Region Headquarters  
5200 Blue Lagoon Drive, Suite #950  
Miami, Florida 33126  
U.S.A.  
(tel) (305) 267 4245  
(fax) (305) 267 4286

### **Australia/New Zealand:**

Agilent Technologies Australia Pty Ltd  
347 Burwood Highway  
Forest Hill, Victoria 3131  
(tel) 1-800 629 485 (Australia)